

**BARNSTABLE AFFORDABLE HOUSING  
AND GROWTH DEVELOPMENT TRUST**

**DEVELOPMENT ACTIVITY APPLICATION  
HARBOR VUE PROJECT**

**PRESENTED BY WINNCOMPANIES**

**April 2024**



**Barnstable Affordable Housing and Growth Development Trust  
Barnstable Town Hall  
367 Main Street  
Hyannis, MA 02601**

**APPLICATION DEADLINE:**

**Rounds: June 1, 2022 and September 1, 2022**

**DEVELOPMENT FUNDING APPLICATION**

To obtain funding through the **Barnstable Affordable Housing and Growth Development Trust** (the Trust), applicants must submit this completed application and ensure that their request meets the requirements outlined in the Notice of Funding Availability (NOFA) and the Trust's Rules and Regulations <https://townofbarnstable.us/BoardsCommittees/AffordableHousingGrowth/Information/>

**Application Process**

Submit completed application with attachments and cover letter electronically to: [AffordableHousingTrust@town.barnstable.ma.us](mailto:AffordableHousingTrust@town.barnstable.ma.us). If you are unable to submit an application electronically, please send the completed application to:

Affordable Housing/Growth & Development Trust Fund  
Office of Town Manager  
367 Main Street  
Hyannis, MA 02601

If you are seeking funds to convert an existing market rate unit or units to an affordable unit or units, upon submission of your application, you will be contacted by the Trust to set up an appointment for inspection of the unit by an inspector selected by the Trust.

**1. PROJECT INFORMATION:**

Name of Project:	Harbor Vue		
Address of Project:	307 Main Street		
Town:	Barnstable	Village	Hyannis
Zip:	02061		
Map	Parcel		

Contact Person Name and Title	Ramie Schneider, Senior Project Director - Adam Stein, EVP		
Mailing address	One Washington Mall, Suite 500, Boston, MA 02108		
Telephone	(617) 239- 4520		

Email rschneider@winnco.com - astein@winnco.com

Budget Summary:	
Total Project Cost:	\$79,898,833.00
Total Trust Funds Requested:	\$2,000,000.00

**2. Summary of Use of Requested Funds (All that apply)**

- Acquisition \_\_\_\_\_
- Rehabilitation/ \_\_\_\_\_
- Site Preparation \_\_\_\_\_
- New construction \_\_\_\_\_
- Redevelopment \_\_\_\_\_
- Direct Assistance \_\_\_\_\_
- Other \_\_\_\_\_

**3. Type of Housing (all that apply)                      Number of Units**

- Homeownership Single family \_\_\_\_\_
- Homeownership Condominium \_\_\_\_\_
- Rental \_\_\_\_\_
- Group Residence \_\_\_\_\_
- Single Room Occupancy \_\_\_\_\_
- Other \_\_\_\_\_

**4. MAPS OF THE FOLLOWING:**

A. Identification of locus of development	Exhibit 2.
B. Site plan showing lot lines, building footprint and general dimensions	Exhibit 2.

**5. DESCRIPTION OF THE PROJECT:** Narrative description of the proposed project.

Exhibit 11.

**6. COMMUNITY NEED** Describe how the project meets the funding priorities as outlined in the Trust's Notice of Funding Availability.

Harbor Vue will serve to address the need for Workforce and Affordable housing in Hyannis. In addition, because 25% of our units will be at 80% AMI or less, all 120 units will count towards Barnstable's SHI (Subsidized Housing Inventory) requirement which is currently 6.78%. Furthermore, the development program aligns with the Affordable Housing Trust Fund priorities by targeting residents of all income brackets from 30% AMI, to 120% AMI, and market rate. The project will provide a much-needed solution to Cape Cods acute housing needs.

**7. PROJECT DETAILS:**

Development Name:	Harbor Vue				
Construction Plans and Specifications (please attach)					
Proposed Uses(s):	Residential S. F.:		Other S.F.:		
Total Floor Area:	96,829				
Total Number of Units:	0BR: 10	1 BR	2 BR	3 BR	4 BR
Total Number of Affordable Units for Sale/Rent:	70	1 BR	2 BR	3 BR	4 BR 0 BR: 9
Total Number of Market Rate Units Sale/Rent:		1 BR	2 BR	3 BR	4 BR

Unit and Income Mix for Sale/Rent \*Affordable unit count includes 32 workforce units set aside at 120% AMI

UNIT SIZE	120% of AMI	60% of AMI	MRVP @ 60% AMI or less	PBV @ 60% AMI or less	Market	Total
SRO						
0 Bedroom/Studio	2	5	1	1	1	10
1 Bedroom						
2 Bedroom						
3 Bedroom						
4 + Bedroom						
Total						

Site Control: What form of site control do you have? (attach details) Purchase and Sale. Exhibit 3.

Zoning and Other Regulatory: Does the present zoning allow for the proposed development? Yes \_\_\_ No \_\_\_  
If no, submit copies of zoning approvals. Describe what, if any, other regulatory approvals are required to implement the proposed development program, e.g., historic district commission, conservation commission, etc.

Existing Conditions: What is the current use of property?  
 Number of existing structures? \_\_\_ Gross s.f. of existing structures \_\_\_  
 Number of existing residential units \_\_\_ Number of new residential units to be created \_\_\_  
 Number of new affordable/community housing units to be created \_\_\_ If site includes commercial space, s.f. \_\_\_

Amenities and services to be offered:	Anticipated amenities: Granite counter tops, stainless appliances, in-unit washer/ dryer, fitness center, secure common lobby & public community room (per zoning), outdoor roof deck, bike storage, dedicated mail & package room, electric auto charging station.
Construction Cost Estimates–attach	
General Development Costs- complete attached form	Exhibit 7.
Management Plan – attach	Exhibit 4.
Identification of all funding sources committed:	We're applying in the 2024 Summer mini funding round for federal and state LIHTC (4% & 9%), MassHousing Workforce Housing Funds, and EOHLC soft debt sources.

**8 . DEVELOPMENT TEAM:**

• Owner
• Developer
• General Partner
• Development Consultant
• Architect
• Contractor
• Construction Manager
• Management Agent
• Attorneys (real estate & tax)
• Guarantor
• Service Provider
• Other role
• Others

**9. DEVELOPER EXPERIENCE AND CAPACITY:** Describe relevant background and/or experience that demonstrate the capacity of the development team to successfully carry out the proposed project. Please include letters of interest from construction and/or permanent lenders. For-profit development, provide three lender references. For non-profit developers, provide current year's operating budget and most recent audited financial statements. See checklist of exhibits.

**10. PROJECT DESIGN AND ACCESSIBILITY:** Attach copies of site plan, floor plans, elevations, and/or specifications that will clearly indicate the scope of work to be undertaken and the types of materials to be used. Describe any sustainable design elements (building orientation, energy efficient envelope, mechanical systems in excess of code requirements, healthy indoor air quality, recycling of building materials, renewable energy, etc.). Describe how many units each will be accessible to households with mobility and sensory impairments.

**11. PROJECT SCHEDULE: (Milestones) Attach project timeline.**

Trust Application Date:	April, 2024
Construction Start:	Q1 2026
50% Construction completion:	Q1 2027
Construction Completion:	Q1 2028
First Certificate of Occupancy	
Last Certificate of Occupancy	
Permanent Loan closing:	Q4 2028
Full Lease Up:	
Other tasks:	

**12. PROJECT FINANCING:**

<b>A. Development Budget</b>	Project Cost	Cost/Unit	Cost/Sq. Ft.
Number of Units			

<b>Sources:</b>	<b>Amount:</b>
• Developer Equity	
• 1 <sup>st</sup> Mortgage	
• Syndication Bridge Loan	
• Construction Loan	
• Permanent Loan	
• Sale of Units	
• Public Subsidy/source *Fed/state LIHTC	
• Other *MassHousing Workforce, EOHLC, BAHGDT	
<b>Total Sources:</b>	\$79,898,833
<b>Uses:</b>	
• Acquisition	
• Direct Construction Budget	
• General Development Costs	
• Developer Overhead & Fee/Res	
• Reserves	
• Other	
<b>Total Uses</b>	
<b>Total Development Cost</b>	

\*We're showing permanent sources below. We're underwriting 41mm in construction loan to come out at conversion.

<b>B. Projected Rents/Sales:</b>			*Refer to attached rent grid - Exhibit 8 b.
Rental Units:	# of Units:	Square Feet:	Projected Monthly Rents
• 1 Bedroom			\$
• 2 Bedrooms			\$
• 3 Bedrooms			\$
• 0 Bedrooms			\$
For Sale Units:			
• 1 Bedroom			Projected Prices
• 2 Bedroom			\$
• 3 Bedroom			\$
• 4 Bedroom			\$
Commercial Space			\$

\*Refer to property operations exhibit 8

<b>Operating Budget</b>	<b>Project</b>	<b>Unit</b>
<b>Income</b>		
Rents		
<b>Less</b>		
Vacancy		
<b>Gross Effective Rent</b>		
Management Fee		
Administration		
Maintenance/Operations		
Resident Services		
Utilities		
Security		
Taxes		
Insurance		
Replacement reserve		
Operating reserve		
<b>TOTAL OPERATING EXPENSES</b>		

### **13. THRESHOLD SCORING SYSTEM-COMPLETE FOR PROJECTS OF TEN OR MORE UNITS**

Complete the following form to determine your analysis of the project's ability to meet the 65-point minimum scoring threshold for Trust Funding. **Bonus points are not included in the 65-point threshold.**

#### **1. Affordability: Maximum total points 25 points**

##### **a. Number of units at targeted affordability: Maximum Points 15**

1-50% AMI: **3 points per unit**

51-80% AMI: **2 points per unit**

81-100% AMI: **1 point per unit**

**Points: \_\_\_\_\_**

**b. Percentage of affordability in development: Maximum Points 10**

Up to 9%: **0 points**

10 – 24%: **3 points**

25-49%: **5 points**

50-100%: **10 points**

**Points: \_\_\_\_**

**2. Amount of other funds to leverage Trust investment: Total Maximum Points 10 points**

Percentage of Trust request match by other subsidies:

85%-100%: **10 points**

50%-84%: **5 points**

25%-49%: **3 points**

10%-25%: **1 point**

**Points: \_\_\_\_**

**3. Strength of Overall Concept: Total Maximum Points 20 + 6 Bonus points**

That the market demand for the unit mix, size and type has been demonstrated **3 points**

That the building design compliments the local, existing design vernacular of Barnstable. **3 points**

That the site design allows for safe, efficient traffic and has recreational open space. In evaluating the sufficiency of the proposed recreational open space, whether the anticipated population to be served would benefit from a playground will be considered. **5 points**

That the design of the affordable and market rate units is not readily distinguishable, that the bedroom unit mix is proportionately distributed between the market rate and the affordable units, that the market rate units and affordable units are on equal footing in terms of basic amenities and that the affordable units are interspersed with the market units. **5 points**

That the Project is consistent with sustainable development and smart growth principles, including elements of green design and energy efficiencies **3 points**.

**Bonus:** Connection to sewer or wastewater treatment plant: **2 points**; Development is certifiable by LEED, Enterprise Green or comparable: **2 points**; Zero Energy Buildings: **2 points**.

That the Project provides additional public benefits such as neighborhood stabilization, infrastructure improvements, economic development and open space **1 point**

**Points: \_\_\_\_**



**4. Strength of Development Team: Total Maximum Points 15**

Experience of applicant and of development team members in developing residential projects of the type, size and complexity proposed: **5 points**

Experience with affordable housing development of this size and complexity: **1 point**

The financial strength of the developer evidenced by lender and banking references: **5 points**

Demonstration of deep understanding of fair housing and management of affordable housing: **3 points**

Status of compliance/good standing with other subsidy programs: **1 point**

**Not eligible for funding if not in good standing.**

**Points: \_\_\_\_**

**5. Whether the Development and Operating Costs are reasonable for a project of its size and are consistent with industry standards, the financial feasibility of the project, and that the development requires the subsidy requested: Maximum Points 20 points**

Demonstration that the average per sq. foot costs, soft costs and developer's overhead and profit meet industry standards: **10 points.**

That the financial feasibility of the project requires the subsidy requested as evidenced by the financial review and analysis: **10 points**

**Points: \_\_\_\_**

**6. Number and Percentage of Units that are accessible to individuals with disabilities  
Maximum Points 5**

Percentage of total project units are handicap accessible:

6 - 10%: **2 points**

Over 10%: **5 points**

**Points: \_\_\_\_**

**7. Readiness to Proceed: Maximum points 5 points**

All necessary permits in hand and at least preliminary commitments from other financing sources.

**Points: \_\_\_\_**

**BONUS POINTS FOR PRIORITY PROJECTS**  
**(Also factor to be considered in the amount of funding to be awarded)**

- Affordable rental housing in areas outside of Hyannis (Up to 10 points)
- Rental units that are affordable to households at or below 50% Area Median Income (AMI) (Up to 10 points) - **10**
- Projects that propose the creation of affordable and community housing homeownership units in Hyannis (Up to 10 points)
- Projects that provide housing to vulnerable populations and offer supportive services (Up to 10 points) - **5**
- Projects that are on public land (Up to 10 points)
- Projects that convert existing buildings and structures into new affordable/community housing units (Up to 10 points). - **10**

**TOTAL POINTS:** \_\_\_\_\_

\*Total score includes 5 points under supportive housing for resident services provided by our Connected Communities program

**Checklist for Exhibits to Application, where applicable**

Exhibit 1: Organization Documents (Articles of Organization)

Exhibit 2: Site Information: Site plan showing lot lines, building footprint, parking, landscaping, and general dimensions

Exhibit 3: Evidence of Site Control

Exhibit 4: Management Plan; Management Agent Profile

Exhibit 5: Construction Plans including exterior elevations, floor layouts, typical unit plan, and a color rendering

Exhibit 6: Documentation of any Funding Commitments and/or schedule for application or award of funds

Exhibit 7: Direct Construction Budget

Exhibit 8: Development Pro-forma. Complete attached form

Exhibit 9: Developer Team Resumes and Qualifications

Exhibit 10: Letters of interest from construction and/or permanent lenders; For-profit development, provide three lender references. For non-profit developers, provide current year's operating budget and most recent audited financial statements.

Signature:	Date:
Print Name:	Title:

**Exhibit 1.**

**Organization Documents**

**CERTIFICATE OF LIMITED PARTNERSHIP  
OF  
307 MAIN FOUR LIMITED PARTNERSHIP**

307 Main Four Limited Partnership (the "Partnership") is hereby formed as a limited partnership under Massachusetts General Laws, Chapter 109 (the "Act").

Pursuant to and in accordance with Massachusetts General Laws Chapter 109, the general partner of the Partnership does hereby (a) execute this Certificate of Limited Partnership of the Partnership and (b) file this Certificate in the Filing Office as required by the Act. Such execution constitutes an affirmation under the penalties and perjury that the facts stated in this Certificate are true.

I. Name of the Partnership. The name of the Partnership is 307 Main Four Limited Partnership.

II. General Character of Business. The purpose and business of the Partnership (which business the Partnership may conduct on its own behalf or as a partner, shareholder, beneficiary or member of another entity) is (a) to acquire, own, manage, operate, maintain, develop, rehabilitate, repair, improve, service, finance, lease, sell, dispose of and otherwise deal with real property and the buildings thereon, including without limitation, multi-family rental housing and related facilities, (b) to acquire any real or personal property necessary to carry out such purposes, (c) to enter into contracts relating to the same, (d) to engage in any and all activities which are necessary or incidental to such purposes, and (e) to act for any other purpose permitted under law.

III. Post Office Address and Address of Agent for Service of Process. The post office address of the office of the Partnership, at which records required to be maintained by the Act are kept, is c/o WinnCompanies, One Washington Mall, Suite 500, Boston, Massachusetts 02108. The resident agent of the Partnership is Gilbert J. Winn, c/o WinnCompanies, One Washington Mall, Boston, Massachusetts, 02108.

IV. General Partner. The name and business address of the general partner of the Partnership is as follows:

<u>Name</u>	<u>Address</u>
307 Main Four GP LLC	c/o WinnCompanies One Washington Mall, Suite 500 Boston, Massachusetts 02108

V. Dissolution and Winding Up. The latest date upon which the Partnership is to be dissolved and its affairs wound up is December 31, 2110.

DocuSign Envelope ID: B19A6F3C-6337-420C-A2A3-D926A5F673CF

IN WITNESS WHEREOF, the undersigned, being the General Partner of the Partnership, has executed and acknowledged this Certificate of Limited Partnership this 24<sup>th</sup> day of July, 2023.

**GENERAL PARTNER:**

307 Main Four GP LLC

By: WDP Manager Corp., its Manager

By:   
EBC867872FD3437...  
Gilbert J. Winn, President

**CONSENT OF RESIDENT AGENT**

I, Gilbert J. Winn, resident agent of the above limited partnership, consent to my appointment as resident agent pursuant to M.G.L. c.109 Section 8 (a).

  
EBC867872FD3437...  
Gilbert J. Winn

THE COMMONWEALTH OF MASSACHUSETTS

I hereby certify that, upon examination of this document, duly submitted to me, it appears that the provisions of the General Laws relative to corporations have been complied with, and I hereby approve said articles; and the filing fee having been paid, said articles are deemed to have been filed with me on:

July 25, 2023 10:36 AM

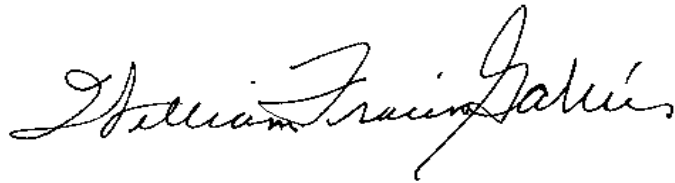
A handwritten signature in black ink, reading "William Francis Galvin". The signature is written in a cursive style with a large, prominent initial "W".

WILLIAM FRANCIS GALVIN

*Secretary of the Commonwealth*

**CERTIFICATE OF LIMITED PARTNERSHIP  
OF  
307 MAIN NINE LIMITED PARTNERSHIP**

307 Main Nine Limited Partnership (the "Partnership") is hereby formed as a limited partnership under Massachusetts General Laws, Chapter 109 (the "Act").

Pursuant to and in accordance with Massachusetts General Laws Chapter 109, the general partner of the Partnership does hereby (a) execute this Certificate of Limited Partnership of the Partnership and (b) file this Certificate in the Filing Office as required by the Act. Such execution constitutes an affirmation under the penalties and perjury that the facts stated in this Certificate are true.

I. Name of the Partnership. The name of the Partnership is 307 Main Nine Limited Partnership.

II. General Character of Business. The purpose and business of the Partnership (which business the Partnership may conduct on its own behalf or as a partner, shareholder, beneficiary or member of another entity) is (a) to acquire, own, manage, operate, maintain, develop, rehabilitate, repair, improve, service, finance, lease, sell, dispose of and otherwise deal with real property and the buildings thereon, including without limitation, multi-family rental housing and related facilities, (b) to acquire any real or personal property necessary to carry out such purposes, (c) to enter into contracts relating to the same, (d) to engage in any and all activities which are necessary or incidental to such purposes, and (e) to act for any other purpose permitted under law.

III. Post Office Address and Address of Agent for Service of Process. The post office address of the office of the Partnership, at which records required to be maintained by the Act are kept, is c/o WinnCompanies, One Washington Mall, Suite 500, Boston, Massachusetts 02108. The resident agent of the Partnership is Gilbert J. Winn, c/o WinnCompanies, One Washington Mall, Boston, Massachusetts, 02108.

IV. General Partner. The name and business address of the general partner of the Partnership is as follows:

<u>Name</u>	<u>Address</u>
307 Main Nine GP LLC	c/o WinnCompanies One Washington Mall, Suite 500 Boston, Massachusetts 02108

V. Dissolution and Winding Up. The latest date upon which the Partnership is to be dissolved and its affairs wound up is December 31, 2110.

DocuSign Envelope ID: B19A6F3C-6337-420C-A2A3-D926A5F673CF

IN WITNESS WHEREOF, the undersigned, being the General Partner of the Partnership, has executed and acknowledged this Certificate of Limited Partnership this 24<sup>th</sup> day of July, 2023.

**GENERAL PARTNER:**

307 Main Nine GP LLC

By: WDP Manager Corp., its Manager

By:   
EBC867872FD3437...  
Gilbert J. Winn, President

**CONSENT OF RESIDENT AGENT**

I, Gilbert J. Winn, resident agent of the above limited partnership, consent to my appointment as resident agent pursuant to M.G.L. c.109 Section 8 (a).

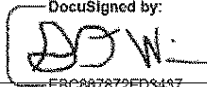
  
EBC867872FD3437...  
Gilbert J. Winn



THE COMMONWEALTH OF MASSACHUSETTS

I hereby certify that, upon examination of this document, duly submitted to me, it appears that the provisions of the General Laws relative to corporations have been complied with, and I hereby approve said articles; and the filing fee having been paid, said articles are deemed to have been filed with me on:

July 25, 2023 10:40 AM

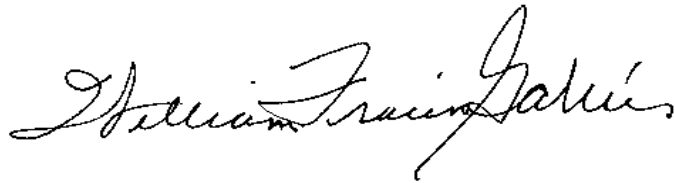
A handwritten signature in black ink, reading "William Francis Galvin". The signature is written in a cursive style with a large, prominent initial "W".

WILLIAM FRANCIS GALVIN

*Secretary of the Commonwealth*

## **Exhibit 2.**

### **Site Information**

**CERTIFICATE OF LIMITED PARTNERSHIP  
OF  
307 MAIN FOUR LIMITED PARTNERSHIP**

307 Main Four Limited Partnership (the "Partnership") is hereby formed as a limited partnership under Massachusetts General Laws, Chapter 109 (the "Act").

Pursuant to and in accordance with Massachusetts General Laws Chapter 109, the general partner of the Partnership does hereby (a) execute this Certificate of Limited Partnership of the Partnership and (b) file this Certificate in the Filing Office as required by the Act. Such execution constitutes an affirmation under the penalties and perjury that the facts stated in this Certificate are true.

I. Name of the Partnership. The name of the Partnership is 307 Main Four Limited Partnership.

II. General Character of Business. The purpose and business of the Partnership (which business the Partnership may conduct on its own behalf or as a partner, shareholder, beneficiary or member of another entity) is (a) to acquire, own, manage, operate, maintain, develop, rehabilitate, repair, improve, service, finance, lease, sell, dispose of and otherwise deal with real property and the buildings thereon, including without limitation, multi-family rental housing and related facilities, (b) to acquire any real or personal property necessary to carry out such purposes, (c) to enter into contracts relating to the same, (d) to engage in any and all activities which are necessary or incidental to such purposes, and (e) to act for any other purpose permitted under law.

III. Post Office Address and Address of Agent for Service of Process. The post office address of the office of the Partnership, at which records required to be maintained by the Act are kept, is c/o WinnCompanies, One Washington Mall, Suite 500, Boston, Massachusetts 02108. The resident agent of the Partnership is Gilbert J. Winn, c/o WinnCompanies, One Washington Mall, Boston, Massachusetts, 02108.

IV. General Partner. The name and business address of the general partner of the Partnership is as follows:

<u>Name</u>	<u>Address</u>
307 Main Four GP LLC	c/o WinnCompanies One Washington Mall, Suite 500 Boston, Massachusetts 02108

V. Dissolution and Winding Up. The latest date upon which the Partnership is to be dissolved and its affairs wound up is December 31, 2110.

DocuSign Envelope ID: B19A6F3C-6337-420C-A2A3-D926A5F673CF

IN WITNESS WHEREOF, the undersigned, being the General Partner of the Partnership, has executed and acknowledged this Certificate of Limited Partnership this 24<sup>th</sup> day of July, 2023.

**GENERAL PARTNER:**

307 Main Four GP LLC

By: WDP Manager Corp., its Manager

By:   
\_\_\_\_\_  
EBC867872FD3437...  
Gilbert J. Winn, President

**CONSENT OF RESIDENT AGENT**

I, Gilbert J. Winn, resident agent of the above limited partnership, consent to my appointment as resident agent pursuant to M.G.L. c.109 Section 8 (a).

  
\_\_\_\_\_  
EBC867872FD3437...  
Gilbert J. Winn

THE COMMONWEALTH OF MASSACHUSETTS

I hereby certify that, upon examination of this document, duly submitted to me, it appears that the provisions of the General Laws relative to corporations have been complied with, and I hereby approve said articles; and the filing fee having been paid, said articles are deemed to have been filed with me on:

July 25, 2023 10:36 AM

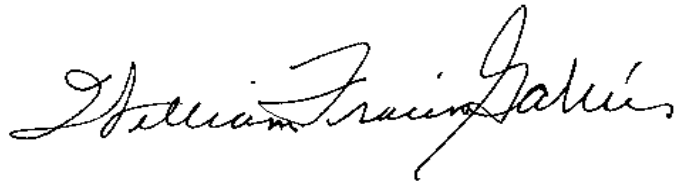
A handwritten signature in black ink, reading "William Francis Galvin". The signature is written in a cursive style with a large, prominent initial 'W'.

WILLIAM FRANCIS GALVIN

*Secretary of the Commonwealth*

**CERTIFICATE OF LIMITED PARTNERSHIP  
OF  
307 MAIN NINE LIMITED PARTNERSHIP**

307 Main Nine Limited Partnership (the "Partnership") is hereby formed as a limited partnership under Massachusetts General Laws, Chapter 109 (the "Act").

Pursuant to and in accordance with Massachusetts General Laws Chapter 109, the general partner of the Partnership does hereby (a) execute this Certificate of Limited Partnership of the Partnership and (b) file this Certificate in the Filing Office as required by the Act. Such execution constitutes an affirmation under the penalties and perjury that the facts stated in this Certificate are true.

I. Name of the Partnership. The name of the Partnership is 307 Main Nine Limited Partnership.

II. General Character of Business. The purpose and business of the Partnership (which business the Partnership may conduct on its own behalf or as a partner, shareholder, beneficiary or member of another entity) is (a) to acquire, own, manage, operate, maintain, develop, rehabilitate, repair, improve, service, finance, lease, sell, dispose of and otherwise deal with real property and the buildings thereon, including without limitation, multi-family rental housing and related facilities, (b) to acquire any real or personal property necessary to carry out such purposes, (c) to enter into contracts relating to the same, (d) to engage in any and all activities which are necessary or incidental to such purposes, and (e) to act for any other purpose permitted under law.

III. Post Office Address and Address of Agent for Service of Process. The post office address of the office of the Partnership, at which records required to be maintained by the Act are kept, is c/o WinnCompanies, One Washington Mall, Suite 500, Boston, Massachusetts 02108. The resident agent of the Partnership is Gilbert J. Winn, c/o WinnCompanies, One Washington Mall, Boston, Massachusetts, 02108.

IV. General Partner. The name and business address of the general partner of the Partnership is as follows:

<u>Name</u>	<u>Address</u>
307 Main Nine GP LLC	c/o WinnCompanies One Washington Mall, Suite 500 Boston, Massachusetts 02108

V. Dissolution and Winding Up. The latest date upon which the Partnership is to be dissolved and its affairs wound up is December 31, 2110.

DocuSign Envelope ID: B19A6F3C-6337-420C-A2A3-D926A5F673CF

IN WITNESS WHEREOF, the undersigned, being the General Partner of the Partnership, has executed and acknowledged this Certificate of Limited Partnership this 24<sup>th</sup> day of July, 2023.

**GENERAL PARTNER:**

307 Main Nine GP LLC

By: WDP Manager Corp., its Manager

By:   
EBC867872FD3437...  
Gilbert J. Winn, President

**CONSENT OF RESIDENT AGENT**

I, Gilbert J. Winn, resident agent of the above limited partnership, consent to my appointment as resident agent pursuant to M.G.L. c.109 Section 8 (a).

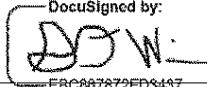
  
EBC867872FD3437...  
Gilbert J. Winn

THE COMMONWEALTH OF MASSACHUSETTS

I hereby certify that, upon examination of this document, duly submitted to me, it appears that the provisions of the General Laws relative to corporations have been complied with, and I hereby approve said articles; and the filing fee having been paid, said articles are deemed to have been filed with me on:

July 25, 2023 10:40 AM

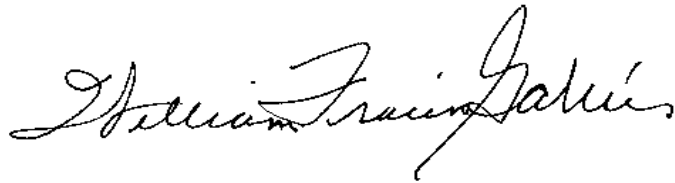
A handwritten signature in black ink, reading "William Francis Galvin". The signature is written in a cursive style with a large, prominent initial "W".

WILLIAM FRANCIS GALVIN

*Secretary of the Commonwealth*



# HARBOR VUE

## IN

# HYANNIS, MASSACHUSETTS

### (Barnstable County)

#### OWNER

307 Main Street Nominee Trust, Conrad Watson, Trustee  
 42C Warehouse Road  
 Hyannis, Massachusetts 02601

#### APPLICANT

WinnDevelopment Company, LP  
 One Washington Mall, Suite 500  
 Boston, Massachusetts 02108

#### ARCHITECT

ICON Architecture  
 101 Summer Street  
 Boston, Massachusetts 02110

#### CIVIL ENGINEER/SURVEY AND LANDSCAPE ARCHITECT

Beals and Thomas, Inc.  
 144 Turnpike Road  
 Southborough, Massachusetts 01772

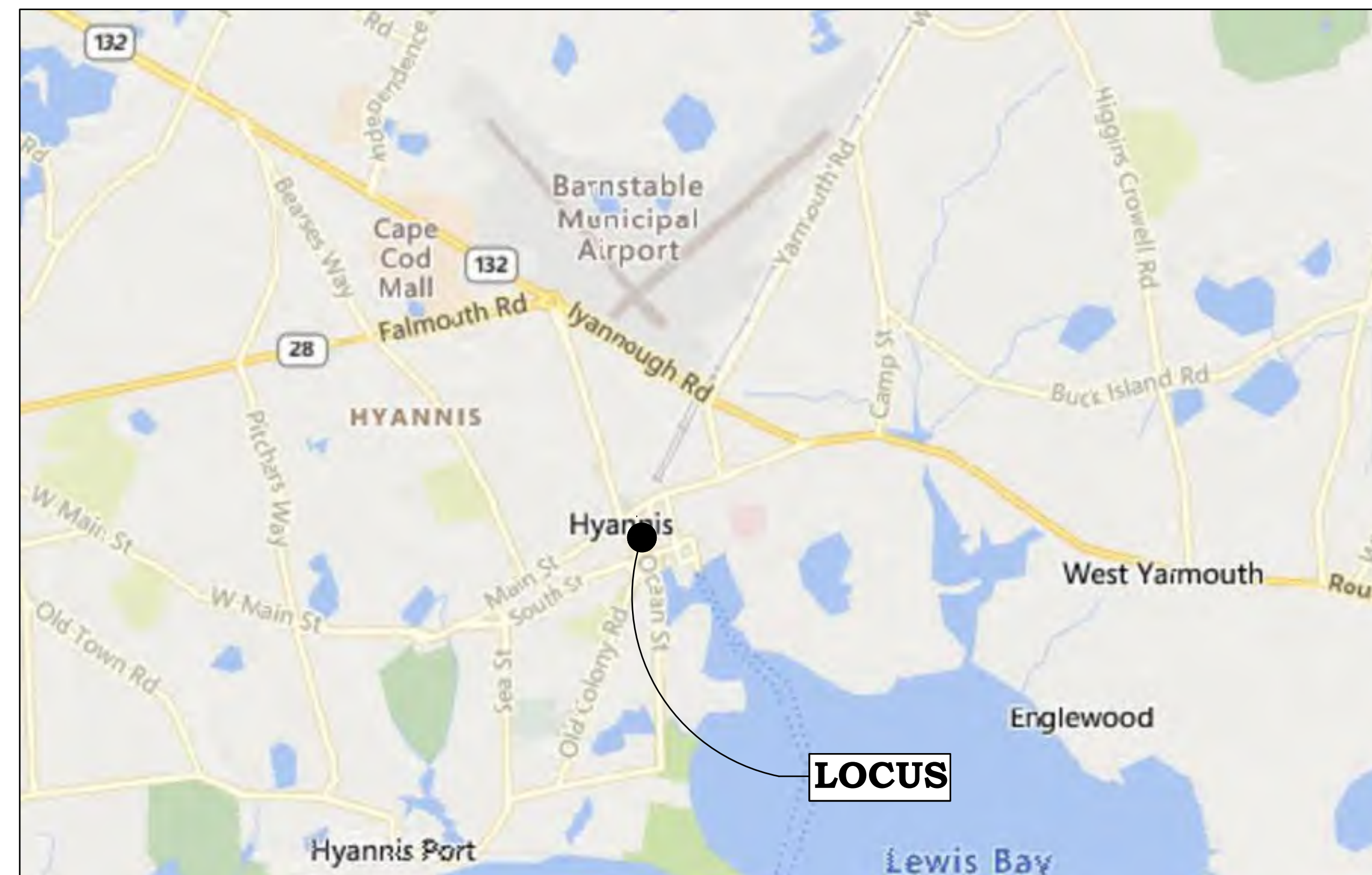

**Locus Map**  
 Scale: 1" = 2,000'



**SITE PLAN REVIEW - JULY 31, 2023**

#### SHEET INDEX

	Cover Sheet
C1.0	Notes, References and Legend
TP-1	Topographic Plan
C2.0	Site Preparation and Sediment Control Plan
C3.0	Layout and Materials Plan
C4.0	Grading and Drainage Plan
C5.0	Utilities Plan
C6.0	Landscape and Lighting Plan
C7.0	Photometric Plan
C8.0 - C8.3	Site Details
A-001	Context Plan
A-002	Site Images
A-003	Zoning Table
A-101	Level 1 Floor Plan
A-102	Levels 2-3 Floor Plan
A-103	Level 4 Floor Plan
A-201	Building Elevations
A-301	Building Sections
A-302	Materials Board
A-303	Perspective Looking South on Main St
A-304	Perspective Looking East on Main St
A-305	Perspective Looking North on Old Colony Rd

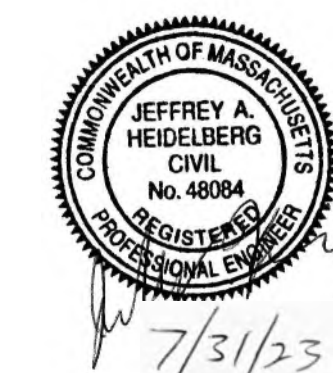

**FOR PERMITTING  
 ONLY**

Job No.: 3447.00  
 Plan No.: 344700P002A-001  
 Sheet 1 of 25



**HARBOR VUE**  
HYANNIS, MA

WinnDevelopment Company, LP

ARCHITECT  
**E-ICON**  
ARCHITECTURE  
101 SUMMER ST BOSTON MA 02110

CONSULTANT  
**BEALS AND THOMAS**  
BEALS AND THOMAS, INC.  
144 Turnpike Road, Suite 210  
Southborough, Massachusetts 01772-2104  
T 508.366.0560 | www.bealsandthomas.com

STAMP  
  
Mark E. Benson  
7/31/2023

KEY PLAN

1	7/31/23	SITE PLAN REVIEW
MARK	DATE	DESCRIPTION

PROJECT NUMBER: 3447.00  
DRAWN BY: SJC/CJA  
CHECKED BY: MEB

SHEET TITLE

**TOPOGRAPHIC PLAN**

SCALE: 1"=20'

**TP-1**

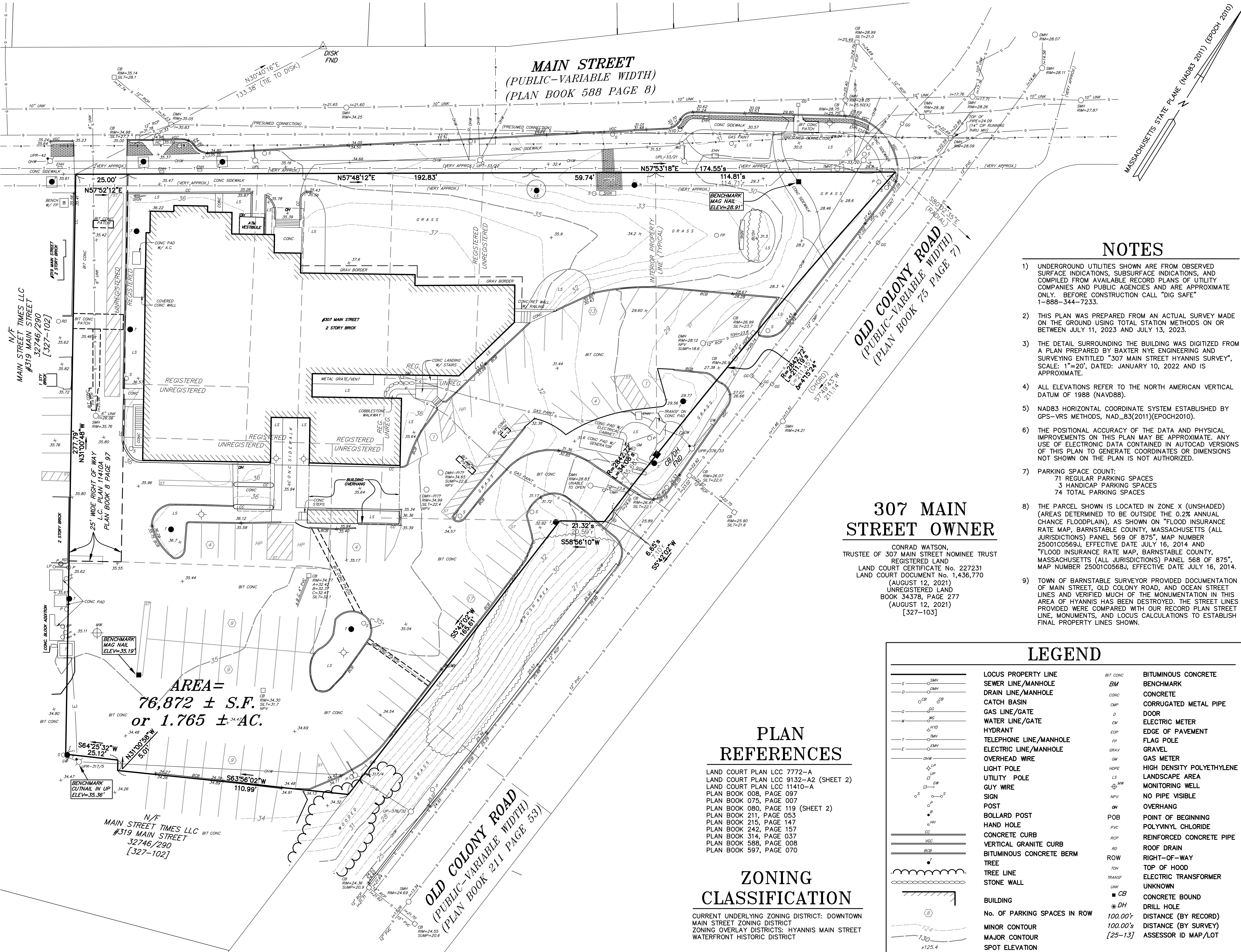

**MAIN STREET**  
(PUBLIC-VARIABLE WIDTH)  
(PLAN BOOK 588 PAGE 8)

**OLD COLONY ROAD**  
(PUBLIC-VARIABLE WIDTH)  
(PLAN BOOK 75 PAGE 7)

**OLD COLONY ROAD**  
(PUBLIC-VARIABLE WIDTH)  
(PLAN BOOK 211 PAGE 53)

**NOTES**

- UNDERGROUND UTILITIES SHOWN ARE FROM OBSERVED SURFACE INDICATIONS, SUBSURFACE INDICATIONS, AND COMPILED FROM AVAILABLE RECORD PLANS OF UTILITY COMPANIES AND PUBLIC AGENCIES AND ARE APPROXIMATE ONLY. BEFORE CONSTRUCTION CALL "DIG SAFE" 1-888-344-7233.
- THIS PLAN WAS PREPARED FROM AN ACTUAL SURVEY MADE ON THE GROUND USING TOTAL STATION METHODS ON OR BETWEEN JULY 11, 2023 AND JULY 13, 2023.
- THE DETAIL SURROUNDING THE BUILDING WAS DIGITIZED FROM A PLAN PREPARED BY BAXTER NYE ENGINEERING AND SURVEYING ENTITLED "307 MAIN STREET HYANNIS SURVEY", SCALE: 1"=20', DATED: JANUARY 10, 2022 AND IS APPROXIMATE.
- ALL ELEVATIONS REFER TO THE NORTH AMERICAN VERTICAL DATUM OF 1988 (NAVD88).
- NAD83 HORIZONTAL COORDINATE SYSTEM ESTABLISHED BY GPS-VRS METHODS, NAD\_83(2011)(EPOCH2010).
- THE POSITIONAL ACCURACY OF THE DATA AND PHYSICAL IMPROVEMENTS ON THIS PLAN MAY BE APPROXIMATE. ANY USE OF ELECTRONIC DATA CONTAINED IN AUTOCAD VERSIONS OF THIS PLAN TO GENERATE COORDINATES OR DIMENSIONS NOT SHOWN ON THE PLAN IS NOT AUTHORIZED.
- PARKING SPACE COUNT:  
71 REGULAR PARKING SPACES  
3 HANDICAP PARKING SPACES  
74 TOTAL PARKING SPACES
- THE PARCEL SHOWN IS LOCATED IN ZONE X (UNSHADED) (AREAS DETERMINED TO BE OUTSIDE THE 0.2% ANNUAL CHANCE FLOODPLAIN), AS SHOWN ON "FLOOD INSURANCE RATE MAP, BARNSTABLE COUNTY, MASSACHUSETTS (ALL JURISDICTIONS) PANEL 569 OF 875", MAP NUMBER 25001C0569J, EFFECTIVE DATE JULY 16, 2014 AND "FLOOD INSURANCE RATE MAP, BARNSTABLE COUNTY, MASSACHUSETTS (ALL JURISDICTIONS) PANEL 568 OF 875", MAP NUMBER 25001C0568J, EFFECTIVE DATE JULY 16, 2014.
- TOWN OF BARNSTABLE SURVEYOR PROVIDED DOCUMENTATION OF MAIN STREET, OLD COLONY ROAD, AND OCEAN STREET LINES AND VERIFIED MUCH OF THE MONUMENTATION IN THIS AREA OF HYANNIS HAS BEEN DESTROYED. THE STREET LINES PROVIDED WERE COMPARED WITH OUR RECORD PLAN STREET LINE, MONUMENTS, AND LOCUS CALCULATIONS TO ESTABLISH FINAL PROPERTY LINES SHOWN.

**307 MAIN STREET OWNER**

CONRAD WATSON,  
TRUSTEE OF 307 MAIN STREET NOMINEE TRUST  
REGISTERED LAND  
LAND COURT CERTIFICATE No. 227231  
LAND COURT DOCUMENT No. 1,436,770  
(AUGUST 12, 2021)  
UNREGISTERED LAND  
BOOK 34378, PAGE 277  
(AUGUST 12, 2021)  
[327-103]

AREA=  
**76,872 ± S.F.**  
or **1.765 ± AC.**

**PLAN REFERENCES**

- LAND COURT PLAN LCC 7772-A
- LAND COURT PLAN LCC 9132-A2 (SHEET 2)
- LAND COURT PLAN LCC 11410-A
- PLAN BOOK 008, PAGE 097
- PLAN BOOK 075, PAGE 007
- PLAN BOOK 080, PAGE 119 (SHEET 2)
- PLAN BOOK 211, PAGE 053
- PLAN BOOK 215, PAGE 147
- PLAN BOOK 242, PAGE 157
- PLAN BOOK 314, PAGE 037
- PLAN BOOK 588, PAGE 008
- PLAN BOOK 597, PAGE 070

**ZONING CLASSIFICATION**

CURRENT UNDERLYING ZONING DISTRICT: DOWNTOWN  
MAIN STREET ZONING DISTRICT  
ZONING OVERLAY DISTRICTS: HYANNIS MAIN STREET  
WATERFRONT HISTORIC DISTRICT

**LEGEND**

	LOCUS PROPERTY LINE		BITUMINOUS CONCRETE
	SEWER LINE/MANHOLE		BENCHMARK
	DRAIN LINE/MANHOLE		CONCRETE
	CATCH BASIN		CORRUGATED METAL PIPE
	GAS LINE/GATE		DOOR
	WATER LINE/GATE		ELECTRIC METER
	HYDRANT		EDGE OF PAVEMENT
	TELEPHONE LINE/MANHOLE		FLAG POLE
	ELECTRIC LINE/MANHOLE		GRAVEL
	OVERHEAD WIRE		GAS METER
	LIGHT POLE		HIGH DENSITY POLYETHYLENE
	UTILITY POLE		LANDSCAPE AREA
	GUY WIRE		MONITORING WELL
	SIGN		NO PIPE VISIBLE
	POST		OVERHANG
	BOLLARD POST		POINT OF BEGINNING
	HAND HOLE		POLYVINYL CHLORIDE
	CONCRETE CURB		REINFORCED CONCRETE PIPE
	VERTICAL GRANITE CURB		ROOF DRAIN
	BITUMINOUS CONCRETE BERM		RIGHT-OF-WAY
	TREE		TOP OF HOOD
	TREE LINE		ELECTRIC TRANSFORMER
	STONE WALL		UNKNOWN
	BUILDING		CONCRETE BOUND
	No. OF PARKING SPACES IN ROW		DRILL HOLE
	MINOR CONTOUR		DISTANCE (BY RECORD)
	MAJOR CONTOUR		DISTANCE (BY SURVEY)
	SPOT ELEVATION		ASSESSOR ID MAP/LOT

# HARBOR VUE

HYANNIS, MA

WinnDevelopment Company, LP

ARCHITECT



101 SUMMER ST BOSTON MA 02110

CONSULTANT



BEALS AND THOMAS, INC.  
144 Turnpike Road, Suite 210  
Southborough, Massachusetts 01772-2104  
T 508.366.0560 | www.bealsandthomas.com

STAMP

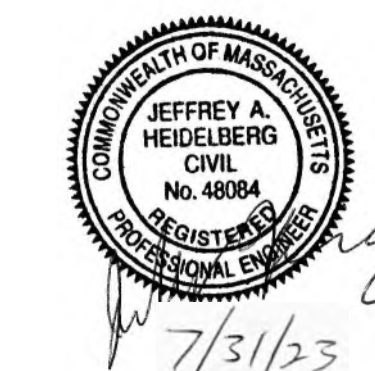

KEY PLAN

**FOR PERMITTING ONLY**

1	7/31/23	SITE PLAN REVIEW
MARK	DATE	DESCRIPTION

PROJECT NUMBER: 3447.00

DRAWN BY:

CHECKED BY:

SHEET TITLE

## SITE PREPARATION AND SEDIMENT CONTROL PLAN

SCALE: 1" = 20'

# C2.0

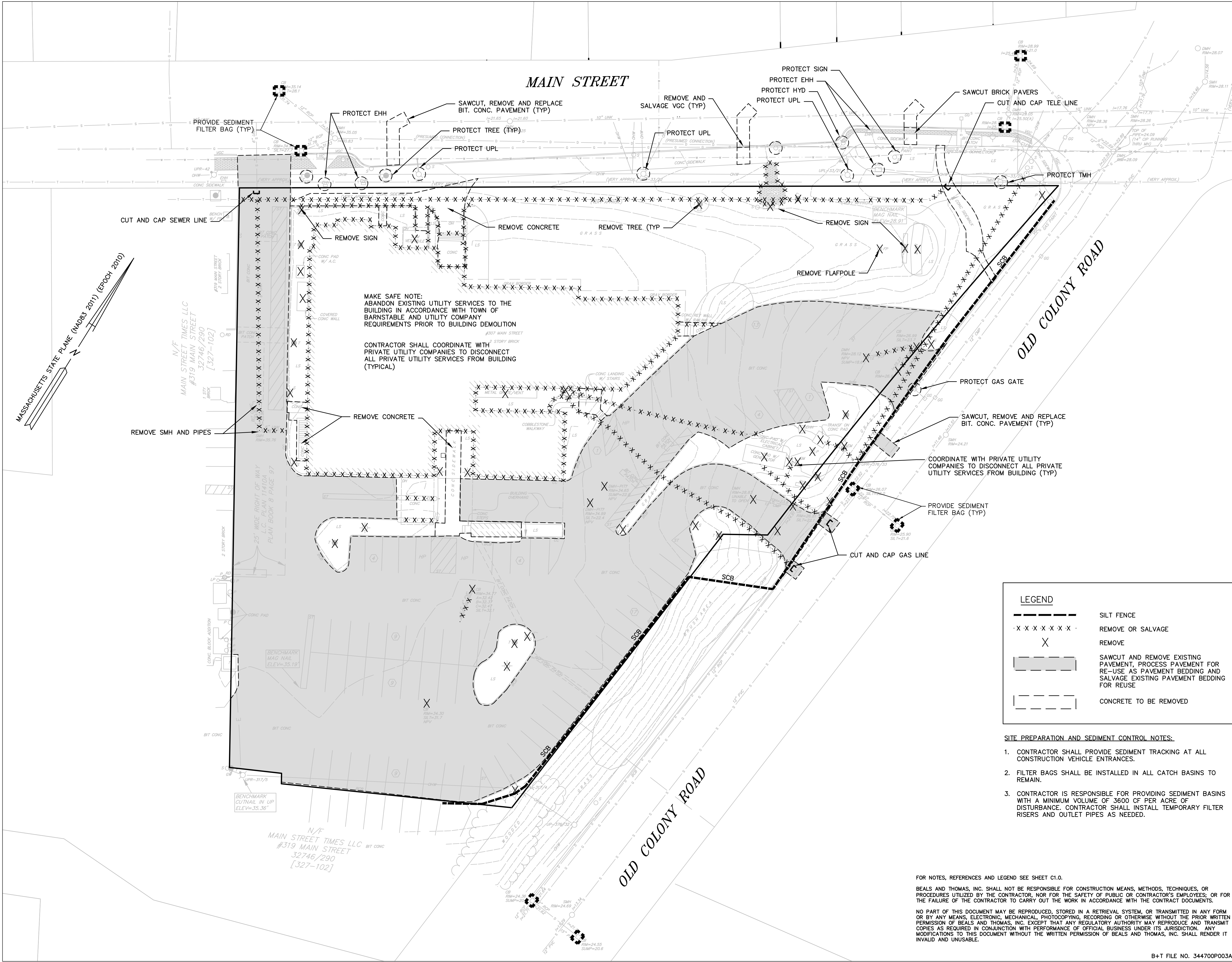

**LEGEND**

- SILT FENCE
- REMOVE OR SALVAGE
- REMOVE
- SAWCUT AND REMOVE EXISTING PAVEMENT, PROCESS PAVEMENT FOR RE-USE AS PAVEMENT BEDDING AND SALVAGE EXISTING PAVEMENT BEDDING FOR REUSE
- CONCRETE TO BE REMOVED

- SITE PREPARATION AND SEDIMENT CONTROL NOTES:**
- CONTRACTOR SHALL PROVIDE SEDIMENT TRACKING AT ALL CONSTRUCTION VEHICLE ENTRANCES.
  - FILTER BAGS SHALL BE INSTALLED IN ALL CATCH BASINS TO REMAIN.
  - CONTRACTOR IS RESPONSIBLE FOR PROVIDING SEDIMENT BASINS WITH A MINIMUM VOLUME OF 3600 CF PER ACRE OF DISTURBANCE. CONTRACTOR SHALL INSTALL TEMPORARY FILTER RISERS AND OUTLET PIPES AS NEEDED.

FOR NOTES, REFERENCES AND LEGEND SEE SHEET C1.0.

BEALS AND THOMAS, INC. SHALL NOT BE RESPONSIBLE FOR CONSTRUCTION MEANS, METHODS, TECHNIQUES, OR PROCEDURES UTILIZED BY THE CONTRACTOR, NOR FOR THE SAFETY OF PUBLIC OR CONTRACTOR'S EMPLOYEES; OR FOR THE FAILURE OF THE CONTRACTOR TO CARRY OUT THE WORK IN ACCORDANCE WITH THE CONTRACT DOCUMENTS.

NO PART OF THIS DOCUMENT MAY BE REPRODUCED, STORED IN A RETRIEVAL SYSTEM, OR TRANSMITTED IN ANY FORM OR BY ANY MEANS, ELECTRONIC, MECHANICAL, PHOTOCOPYING, RECORDING OR OTHERWISE WITHOUT THE PRIOR WRITTEN PERMISSION OF BEALS AND THOMAS, INC. EXCEPT THAT ANY REGULATORY AUTHORITY MAY REPRODUCE AND TRANSMIT COPIES AS REQUIRED IN CONJUNCTION WITH PERFORMANCE OF OFFICIAL BUSINESS UNDER ITS JURISDICTION. ANY MODIFICATIONS TO THIS DOCUMENT WITHOUT THE WRITTEN PERMISSION OF BEALS AND THOMAS, INC. SHALL RENDER IT INVALID AND UNUSABLE.

# HARBOR VUE

HYANNIS, MA

WinnDevelopment Company, LP

ARCHITECT



101 SUMMER ST BOSTON MA 02110

CONSULTANT



BEALS AND THOMAS, INC.  
144 Turnpike Road, Suite 210  
Southborough, Massachusetts 01772-2104  
T 508.366.0560 | www.bealsandthomas.com

STAMP



7/31/23

KEY PLAN

**FOR PERMITTING ONLY**

1	7/31/23	SITE PLAN REVIEW
MARK	DATE	DESCRIPTION

PROJECT NUMBER: 3447.00

DRAWN BY:

CHECKED BY:

SHEET TITLE

LAYOUT AND MATERIALS PLAN

SCALE: 1" = 20'

**C3.0**

B+T FILE NO. 344700P003A-002

## MAIN STREET

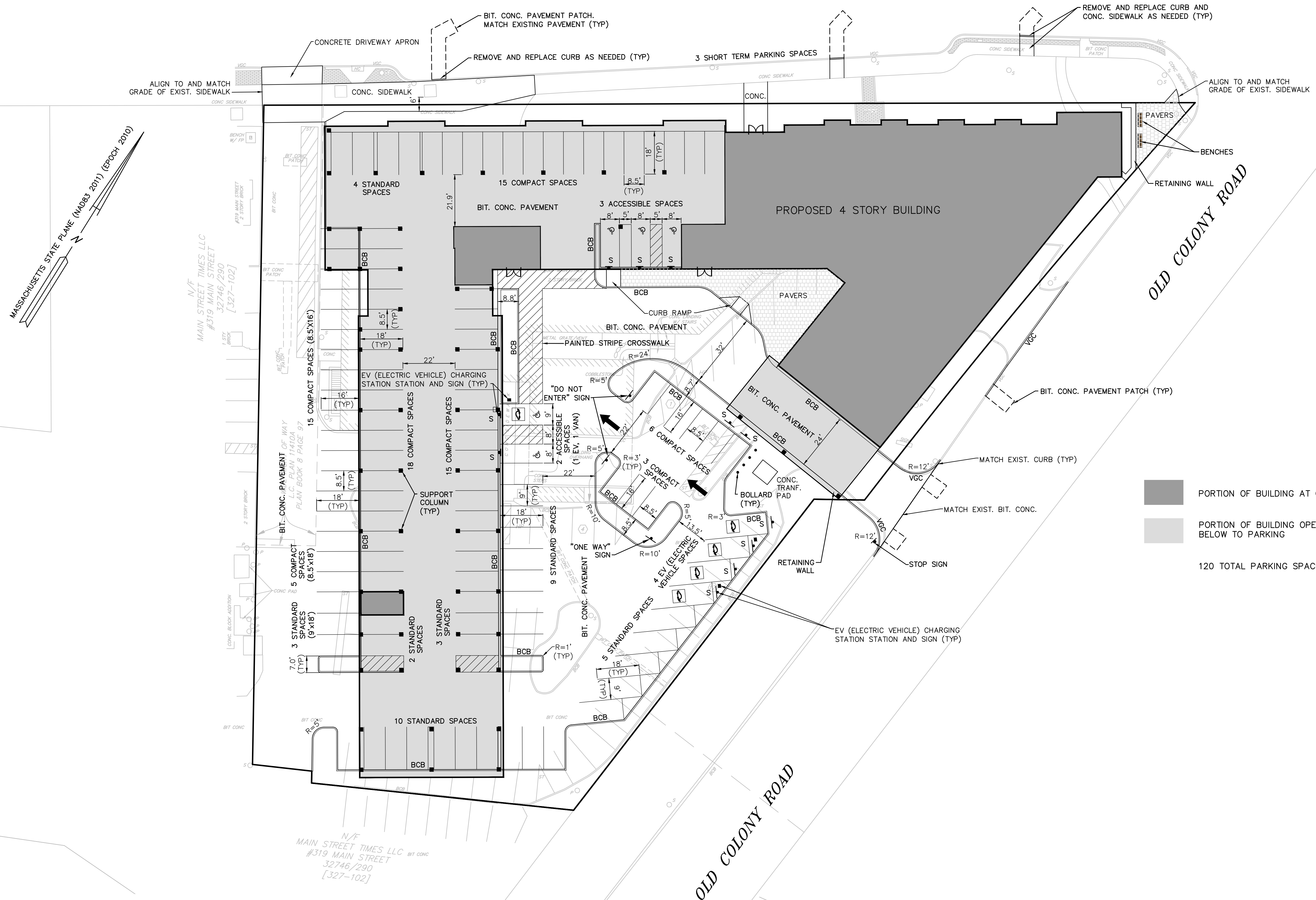

FOR NOTES, REFERENCES AND LEGEND SEE SHEET C1.0.

BEALS AND THOMAS, INC. SHALL NOT BE RESPONSIBLE FOR CONSTRUCTION MEANS, METHODS, TECHNIQUES, OR PROCEDURES UTILIZED BY THE CONTRACTOR, NOR FOR THE SAFETY OF PUBLIC OR CONTRACTOR'S EMPLOYEES; OR FOR THE FAILURE OF THE CONTRACTOR TO CARRY OUT THE WORK IN ACCORDANCE WITH THE CONTRACT DOCUMENTS.

NO PART OF THIS DOCUMENT MAY BE REPRODUCED, STORED IN A RETRIEVAL SYSTEM, OR TRANSMITTED IN ANY FORM OR BY ANY MEANS, ELECTRONIC, MECHANICAL, PHOTOCOPYING, RECORDING OR OTHERWISE WITHOUT THE PRIOR WRITTEN PERMISSION OF BEALS AND THOMAS, INC. EXCEPT THAT ANY REGULATORY AUTHORITY MAY REPRODUCE AND TRANSMIT COPIES AS REQUIRED IN CONJUNCTION WITH PERFORMANCE OF OFFICIAL BUSINESS UNDER ITS JURISDICTION. ANY MODIFICATIONS TO THIS DOCUMENT WITHOUT THE WRITTEN PERMISSION OF BEALS AND THOMAS, INC. SHALL RENDER IT INVALID AND UNUSABLE.

6/27/2023 11:54:06 AM

MAIN STREET

OLD COLONY ROAD

OLD COLONY ROAD

MATCH EXISTING GRADE

MATCH EXISTING GRADE

MATCH EXISTING GRADE

PROPOSED 4 STORY BUILDING  
FFE=33.5

X HP34.0

x33.7

x34.1

x33.5

x33.5

x33.5

x33.5

x33.5

x33.5

x33.5

x33.5

x33.5

x33.5

x33.5

x33.5

x33.5

x33.5

x33.5

x33.5

x33.5

x33.5

x33.5

x33.5

x33.5

x33.5

x33.5

x33.5

x33.5

x33.5

x33.5

x33.5

x33.5

x33.5

x33.5

x33.5

x33.5

x33.5

x33.5

x33.5

x33.5

x33.5

x33.5

x33.5

x33.5

x33.5

x33.5

x33.5

x33.5

x33.5

x33.5

x33.5

x33.5

x33.5

x33.5

x33.5

x33.5

x33.5

x33.5

x33.5

x33.5

x33.5

x33.5

x33.5

x33.5

x33.5

x33.5

x33.5

x33.5

x33.5

N/F  
MAIN STREET TIMES LLC  
#319 MAIN STREET  
32746/290  
[327-102]

N/F  
MAIN STREET TIMES LLC  
#319 MAIN STREET  
32746/290  
[327-102]

MASSACHUSETTS STATE PLANE (NAD83 2011) (EPOCH 2010)

HARBOR VUE  
HYANNIS, MA

WinnDevelopment Company, LP

ARCHITECT  
**ICON**  
ARCHITECTURE  
101 SUMMER ST BOSTON MA 02110

CONSULTANT  
**BEALS AND THOMAS**  
BEALS AND THOMAS, INC.  
144 Turnpike Road, Suite 210  
Southborough, Massachusetts 01772-2104  
T 508.366.0560 | www.bealsandthomas.com

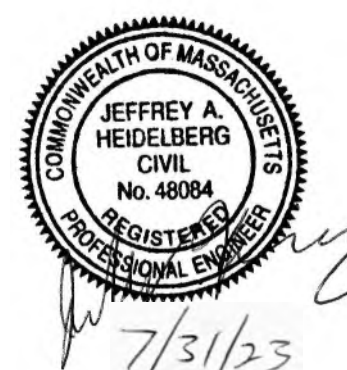
STAMP  

KEY PLAN  
**FOR PERMITTING ONLY**

1	7/31/23	SITE PLAN REVIEW
MARK	DATE	DESCRIPTION
PROJECT NUMBER: 3447.00		
DRAWN BY:		
CHECKED BY:		

SHEET TITLE  
**GRADING AND DRAINAGE PLAN**

SCALE: 1" = 20'  
**C4.0**

FOR NOTES, REFERENCES AND LEGEND SEE SHEET C1.0.  
BEALS AND THOMAS, INC. SHALL NOT BE RESPONSIBLE FOR CONSTRUCTION MEANS, METHODS, TECHNIQUES, OR PROCEDURES UTILIZED BY THE CONTRACTOR, NOR FOR THE SAFETY OF PUBLIC OR CONTRACTOR'S EMPLOYEES; OR FOR THE FAILURE OF THE CONTRACTOR TO CARRY OUT THE WORK IN ACCORDANCE WITH THE CONTRACT DOCUMENTS.  
NO PART OF THIS DOCUMENT MAY BE REPRODUCED, STORED IN A RETRIEVAL SYSTEM, OR TRANSMITTED IN ANY FORM OR BY ANY MEANS, ELECTRONIC, MECHANICAL, PHOTOCOPYING, RECORDING OR OTHERWISE WITHOUT THE PRIOR WRITTEN PERMISSION OF BEALS AND THOMAS, INC. EXCEPT THAT ANY REGULATORY AUTHORITY MAY REPRODUCE AND TRANSMIT COPIES AS REQUIRED IN CONJUNCTION WITH PERFORMANCE OF OFFICIAL BUSINESS UNDER ITS JURISDICTION. ANY MODIFICATIONS TO THIS DOCUMENT WITHOUT THE WRITTEN PERMISSION OF BEALS AND THOMAS, INC. SHALL RENDER IT INVALID AND UNUSABLE.

6/27/2023 11:54:06 AM

**HARBOR VUE**  
HYANNIS, MA

WinnDevelopment Company, LP

ARCHITECT



101 SUMMER ST BOSTON MA 02110

CONSULTANT



BEALS AND THOMAS, INC.  
144 Turnpike Road, Suite 210  
Southborough, Massachusetts 01772-2104  
T 508.366.0560 | www.bealsandthomas.com

STAMP

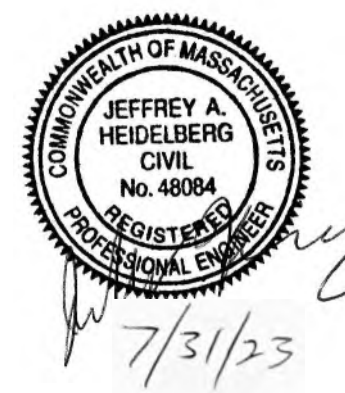

KEY PLAN

**FOR PERMITTING ONLY**

1	7/31/23	SITE PLAN REVIEW
MARK	DATE	DESCRIPTION

PROJECT NUMBER: 3447.00  
DRAWN BY:  
CHECKED BY:

SHEET TITLE

**UTILITIES PLAN**

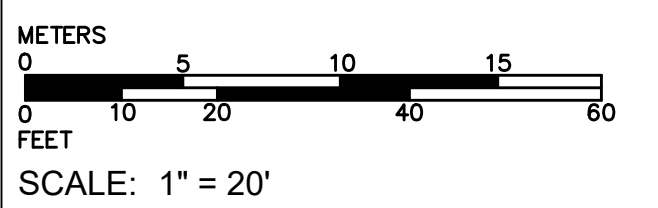

**C5.0**

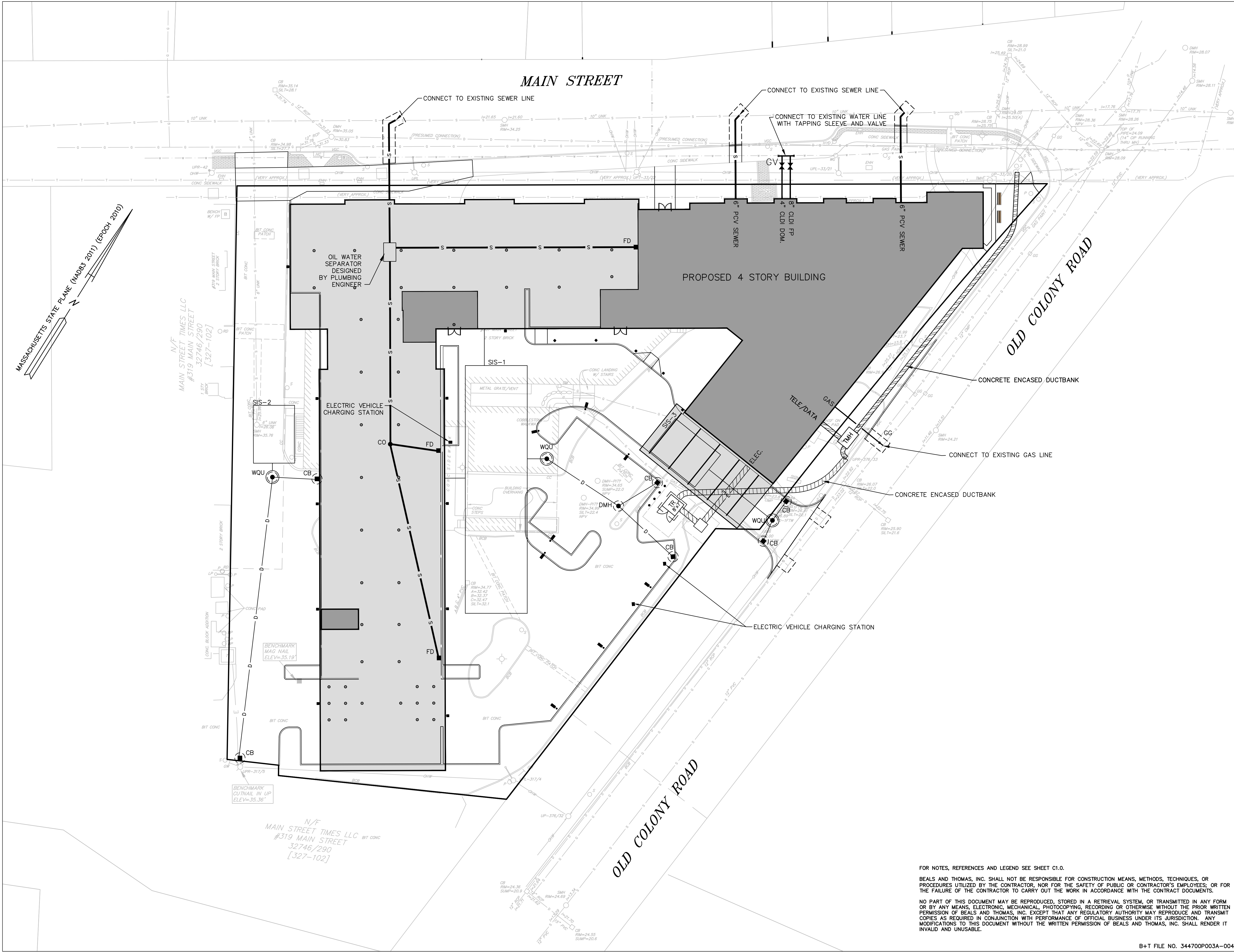

FOR NOTES, REFERENCES AND LEGEND SEE SHEET C1.0.  
BEALS AND THOMAS, INC. SHALL NOT BE RESPONSIBLE FOR CONSTRUCTION MEANS, METHODS, TECHNIQUES, OR PROCEDURES UTILIZED BY THE CONTRACTOR, NOR FOR THE SAFETY OF PUBLIC OR CONTRACTOR'S EMPLOYEES; OR FOR THE FAILURE OF THE CONTRACTOR TO CARRY OUT THE WORK IN ACCORDANCE WITH THE CONTRACT DOCUMENTS.  
NO PART OF THIS DOCUMENT MAY BE REPRODUCED, STORED IN A RETRIEVAL SYSTEM, OR TRANSMITTED IN ANY FORM OR BY ANY MEANS, ELECTRONIC, MECHANICAL, PHOTOCOPYING, RECORDING OR OTHERWISE WITHOUT THE PRIOR WRITTEN PERMISSION OF BEALS AND THOMAS, INC. EXCEPT THAT ANY REGULATORY AUTHORITY MAY REPRODUCE AND TRANSMIT COPIES AS REQUIRED IN CONJUNCTION WITH PERFORMANCE OF OFFICIAL BUSINESS UNDER ITS JURISDICTION. ANY MODIFICATIONS TO THIS DOCUMENT WITHOUT THE WRITTEN PERMISSION OF BEALS AND THOMAS, INC. SHALL RENDER IT INVALID AND UNUSABLE.

# HARBOR VUE

HYANNIS, MA

WinnDevelopment Company, LP

ARCHITECT



101 SUMMER ST BOSTON MA 02110

CONSULTANT



BEALS AND THOMAS, INC.  
144 Turnpike Road, Suite 210  
Southborough, Massachusetts 01772-2104  
T 508.366.0560 | www.bealsandthomas.com

STAMP



KEY PLAN

FOR PERMITTING ONLY

1	7/31/23	SITE PLAN REVIEW
MARK	DATE	DESCRIPTION

PROJECT NUMBER: 3447.00

DRAWN BY:

CHECKED BY:

SHEET TITLE

## LANDSCAPE AND LIGHTING PLAN

SCALE: 1" = 20'

# C6.0

MAIN STREET

OLD COLONY ROAD

OLD COLONY ROAD

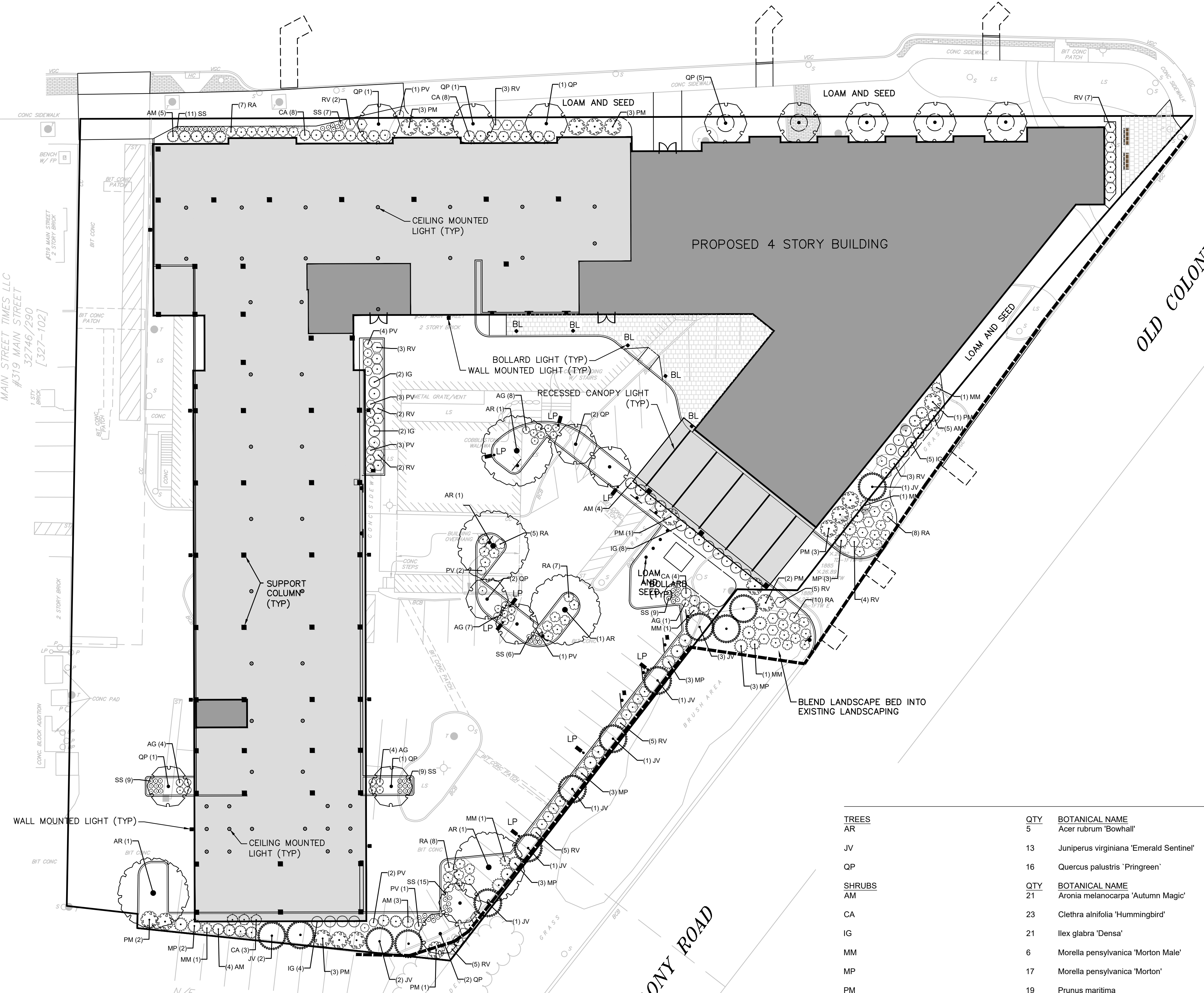

TREES	QTY	BOTANICAL NAME	COMMON NAME	SIZE	CONT.
AR	5	Acer rubrum 'Bowhall'	Bowhall Red Maple	3-3 1/2" cal.	B&B
JV	13	Juniperus virginiana 'Emerald Sentinel'	Emerald Sentinel Red Cedar	7-8' ht.	
QP	16	Quercus palustris 'Pringreen'	Green Pillar® Pin Oak	2-2 1/2" cal.	B&B
SHRUBS	21	BOTANICAL NAME	COMMON NAME	SIZE	CONT.
AM	QTY	Aronia melanocarpa 'Autumn Magic'	Autumn Magic Black Chokeberry	24-30" ht.	5 gal.
CA	23	Clethra alnifolia 'Hummingbird'	Hummingbird Summersweet	24-30" ht.	5 gal.
IG	21	Ilex glabra 'Densa'	Inkberry Holly	24-30" ht.	7 gal.
MM	6	Morella pensylvanica 'Morton Male'	Silver Sprite Male Bayberry	24-30" ht.	5 gal.
MP	17	Morella pensylvanica 'Morton'	Silver Sprite Northern Bayberry	30-36" ht.	B&B
PM	19	Prunus maritima	Beach Plum	36-42" ht.	7 gal.
RA	45	Rhus aromatica 'Gro-Low'	Gro-Low Fragrant Sumac	12-18" ht.	3 gal.
RV	46	Rosa virginiana	Virginia Rose	30-36" ht.	7 gal.
PERENNIALS AND ORNAMENTAL GRASSES	QTY	BOTANICAL NAME	COMMON NAME	SIZE	CONT.
AG	24	Andropogon gerardii	Big Bluestem	24-30" ht.	2 gal.
PV	17	Panicum virgatum 'Heavy Metal'	Heavy Metal Switch Grass	24-30" ht.	5 gal.
SS	66	Schizachyrium scoparium 'Jazz'	Jazz Little Bluestem	8-12" ht.	2 gal.

FOR NOTES, REFERENCES AND LEGEND SEE SHEET C1.0.

BEALS AND THOMAS, INC. SHALL NOT BE RESPONSIBLE FOR CONSTRUCTION MEANS, METHODS, TECHNIQUES, OR PROCEDURES UTILIZED BY THE CONTRACTOR, NOR FOR THE SAFETY OF PUBLIC OR CONTRACTOR'S EMPLOYEES, OR FOR THE FAILURE OF THE CONTRACTOR TO CARRY OUT THE WORK IN ACCORDANCE WITH THE CONTRACT DOCUMENTS.

NO PART OF THIS DOCUMENT MAY BE REPRODUCED, STORED IN A RETRIEVAL SYSTEM, OR TRANSMITTED IN ANY FORM OR BY ANY MEANS, ELECTRONIC, MECHANICAL, PHOTOCOPYING, RECORDING OR OTHERWISE WITHOUT THE PRIOR WRITTEN PERMISSION OF BEALS AND THOMAS, INC. EXCEPT THAT ANY REGULATORY AUTHORITY MAY REPRODUCE AND TRANSMIT COPIES AS REQUIRED IN CONJUNCTION WITH PERFORMANCE OF OFFICIAL BUSINESS UNDER ITS JURISDICTION. ANY MODIFICATIONS TO THIS DOCUMENT WITHOUT THE WRITTEN PERMISSION OF BEALS AND THOMAS, INC. SHALL RENDER IT INVALID AND UNUSABLE.

6/27/2023 11:54:06 AM



**HARBOR VUE**  
HYANNIS, MA

WinnDevelopment Company, LP

ARCHITECT



101 SUMMER ST BOSTON MA 02110

CONSULTANT



BEALS AND THOMAS, INC.  
144 Turnpike Road, Suite 210  
Southborough, Massachusetts 01772-2104  
T 508.366.0560 | www.bealsandthomas.com

STAMP

KEY PLAN

**FOR PERMITTING ONLY**

1	7/31/23	SITE PLAN REVIEW
MARK	DATE	DESCRIPTION

PROJECT NUMBER: 3447.00

DRAWN BY:

CHECKED BY:

SHEET TITLE

**PHOTOMETRIC PLAN**

SCALE: 1" = 20'

**C7.0**

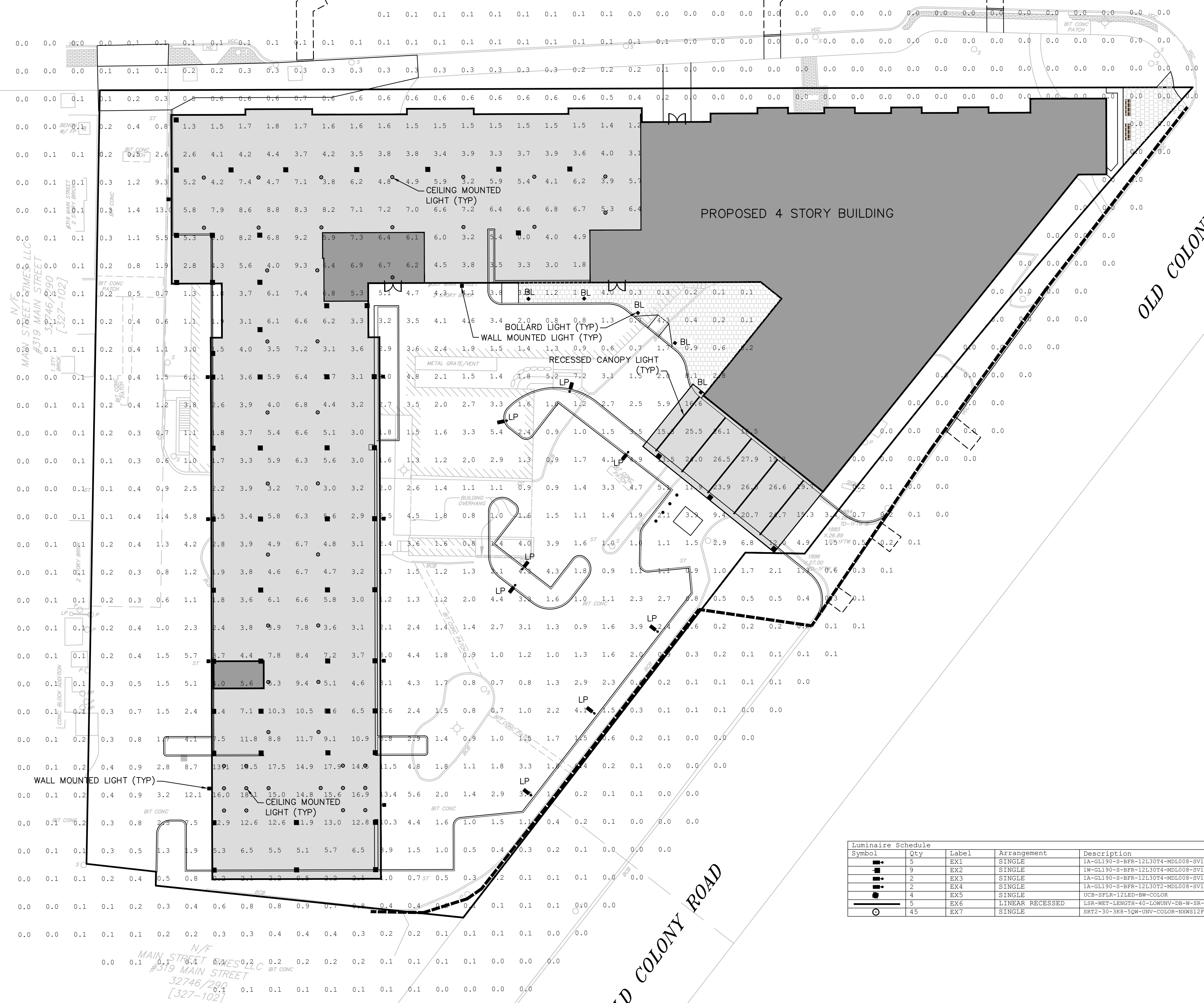

Symbol	Qty	Label	Arrangement	Description	Total Watts	Lum. Lumens
■	5	EX1	SINGLE	1A-GL190-S-BFR-12L3074-MDL008-SVI-HANG-BLOC-COLOR	134	2372
■	9	EX2	SINGLE	1W-GL190-S-BFR-12L3074-MDL008-SVI-HANG-BLOC-COLOR	241.2	2372
■	2	EX3	SINGLE	1A-GL190-S-BFR-12L3074-MDL008-SVI-HANG-COLOR	53.6	3270
■	2	EX4	SINGLE	1A-GL190-S-BFR-12L3072-MDL008-SVI-HANG-BLOC-COLOR	53.4	2634
■	4	EX5	SINGLE	UCB-SFLR-12LED-BW-COLOR	132	703
—	5	EX6	LINEAR RECESSED	LSR-WET-LENGTH-40-LOWUV-DB-W-SR-SD	2500	N.A.
○	45	EX7	SINGLE	SRT2-30-3R8-SQW-UVV-COLOR-NRWS12F	1404	3527

FOR NOTES, REFERENCES AND LEGEND SEE SHEET C1.0.  
BEALS AND THOMAS, INC. SHALL NOT BE RESPONSIBLE FOR CONSTRUCTION MEANS, METHODS, TECHNIQUES, OR PROCEDURES UTILIZED BY THE CONTRACTOR, NOR FOR THE SAFETY OF PUBLIC OR CONTRACTOR'S EMPLOYEES; OR FOR THE FAILURE OF THE CONTRACTOR TO CARRY OUT THE WORK IN ACCORDANCE WITH THE CONTRACT DOCUMENTS.

NO PART OF THIS DOCUMENT MAY BE REPRODUCED, STORED IN A RETRIEVAL SYSTEM, OR TRANSMITTED IN ANY FORM OR BY ANY MEANS, ELECTRONIC, MECHANICAL, PHOTOCOPYING, RECORDING OR OTHERWISE WITHOUT THE PRIOR WRITTEN PERMISSION OF BEALS AND THOMAS, INC. EXCEPT THAT ANY REGULATORY AUTHORITY MAY REPRODUCE AND TRANSMIT COPIES AS REQUIRED IN CONJUNCTION WITH PERFORMANCE OF OFFICIAL BUSINESS UNDER ITS JURISDICTION. ANY MODIFICATIONS TO THIS DOCUMENT WITHOUT THE WRITTEN PERMISSION OF BEALS AND THOMAS, INC. SHALL RENDER IT INVALID AND UNUSABLE.

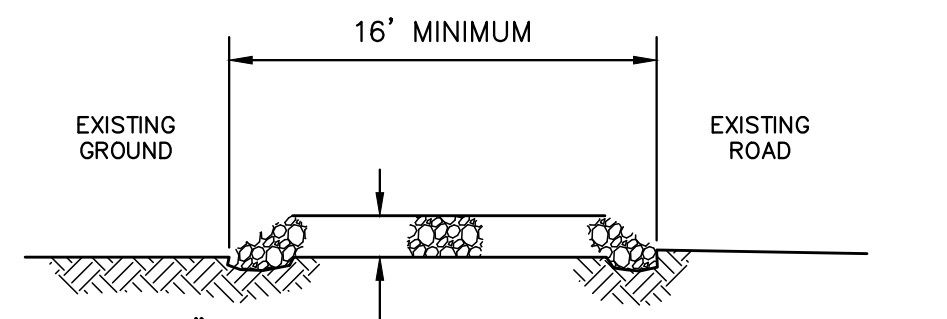

PROFILE VIEW

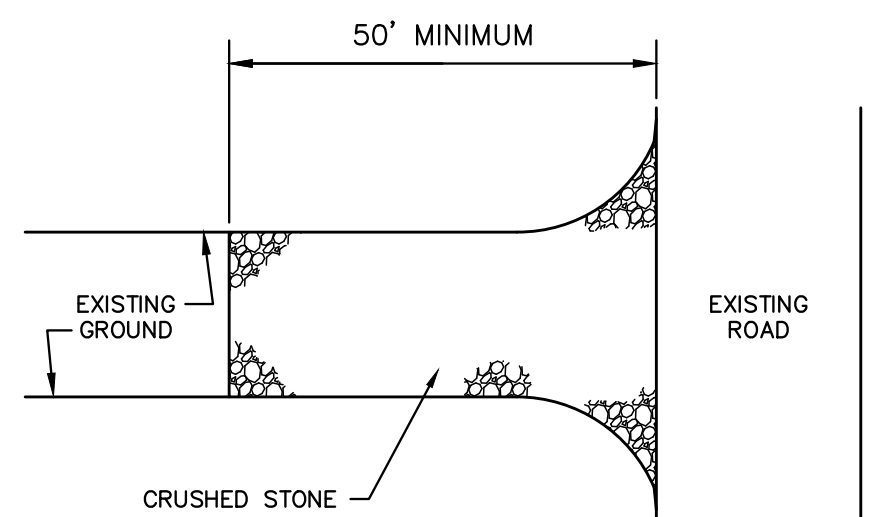

PLAN VIEW

STABILIZED CONSTRUCTION ENTRANCE

NOT TO SCALE

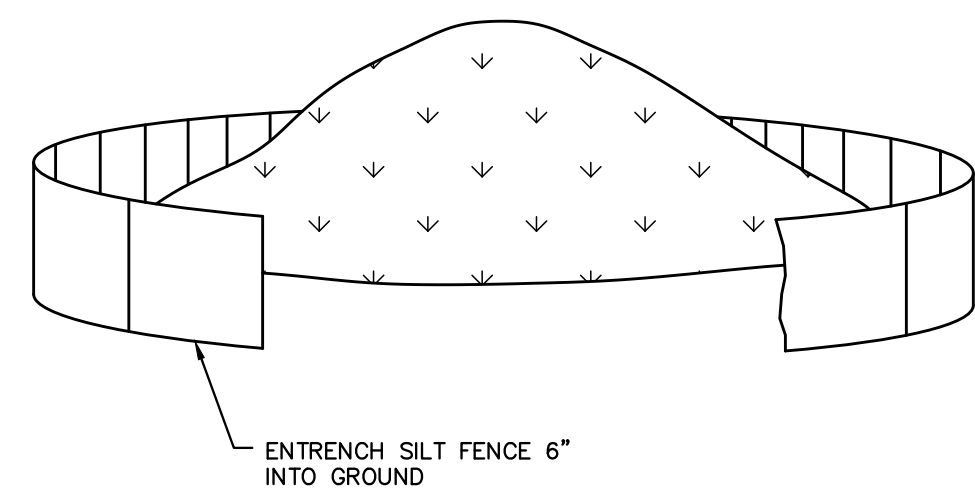

SOIL STOCKPILE

NOT TO SCALE

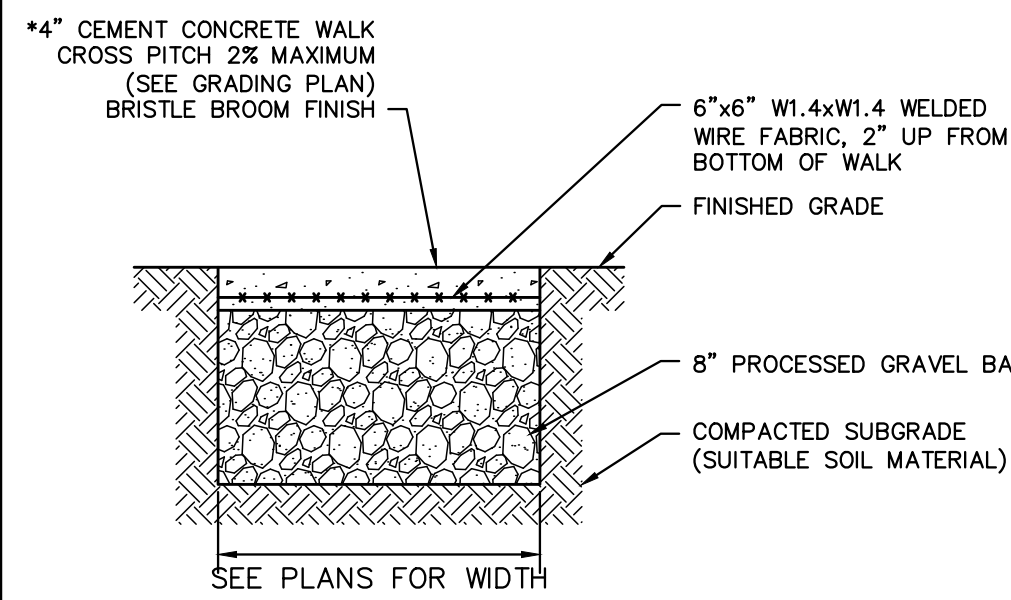

CEMENT CONCRETE WALK

NOT TO SCALE

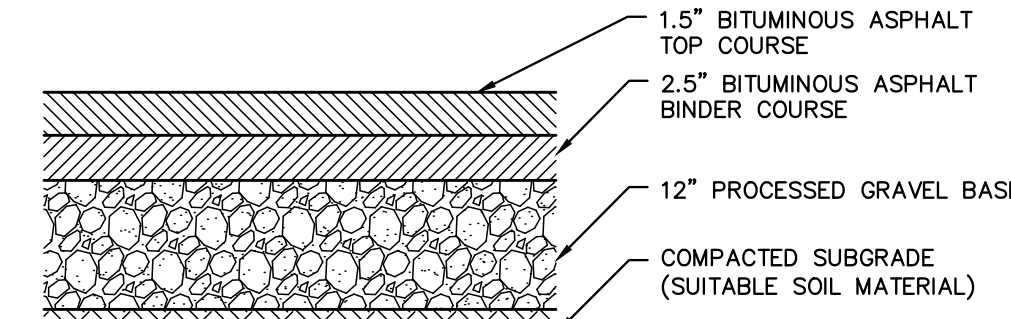

BITUMINOUS CONCRETE PAVEMENT

NOT TO SCALE

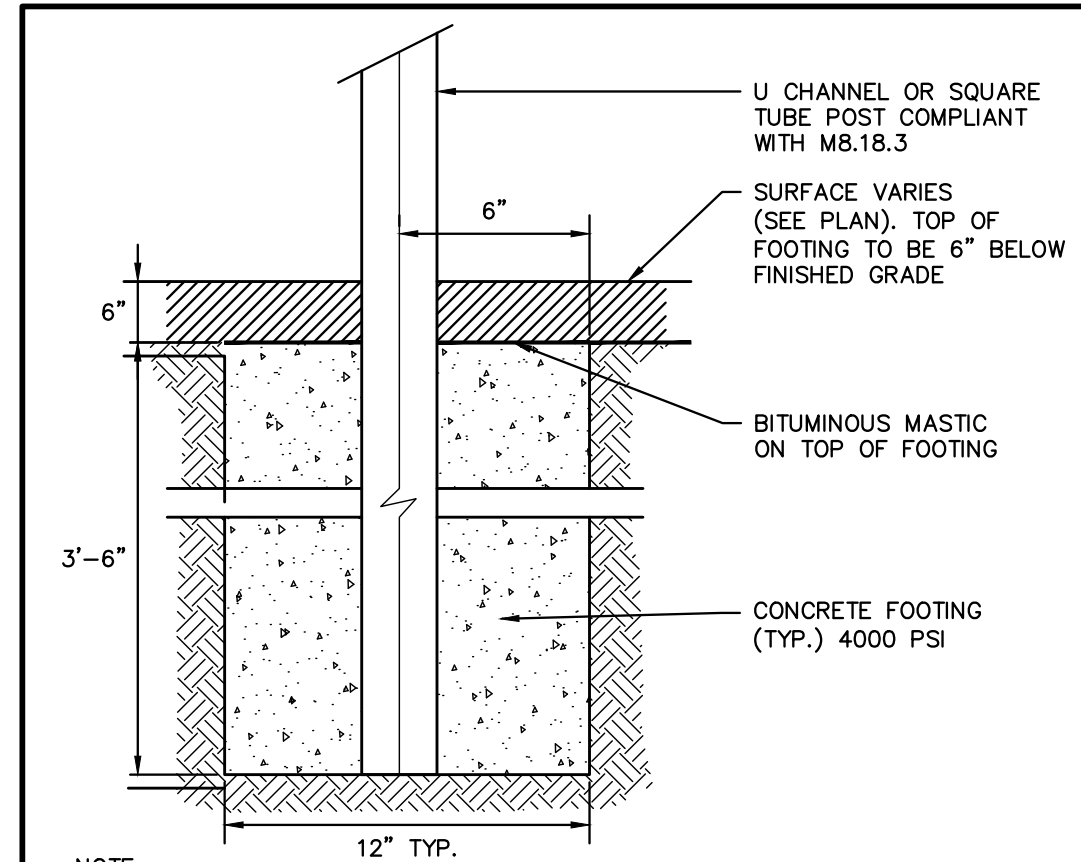

CONCRETE POST & FOOTING DETAIL

NOT TO SCALE

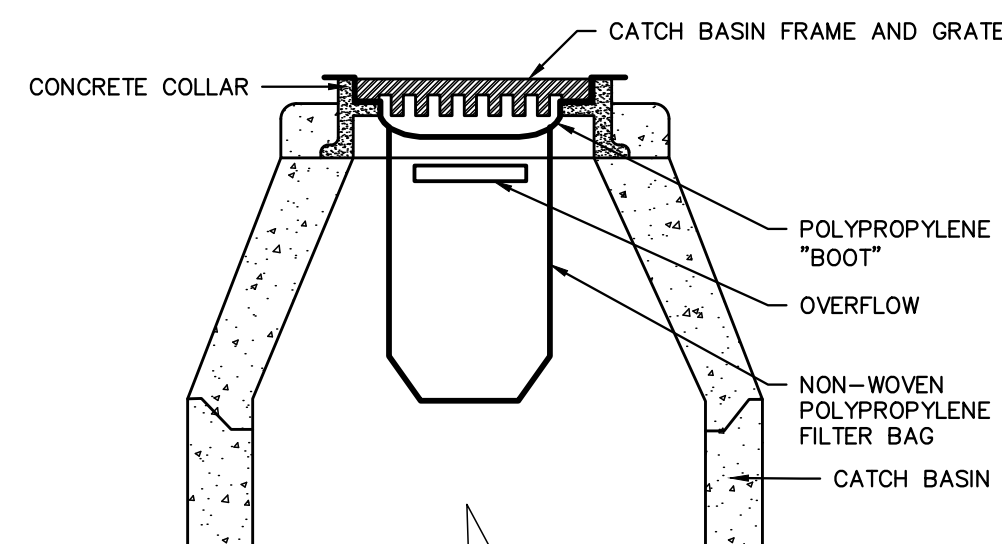

FILTER BAG

NOT TO SCALE

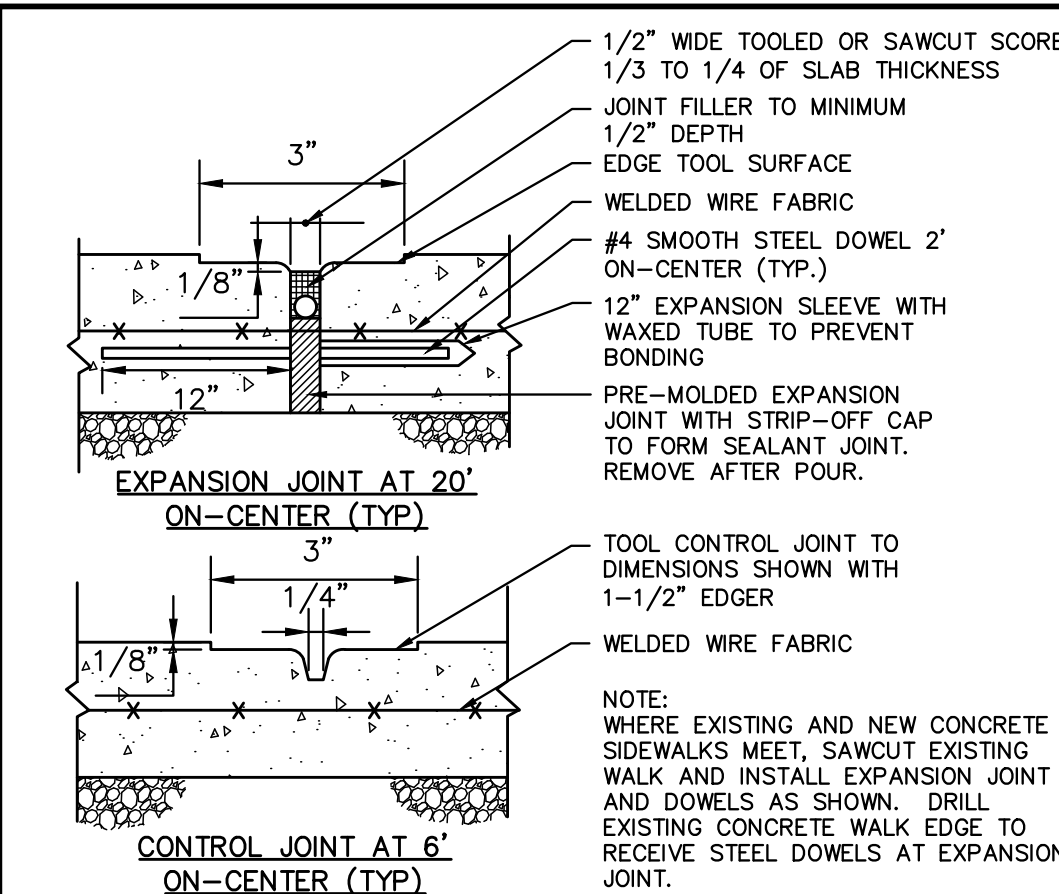

EXPANSION AND CONTROL JOINTS

NOT TO SCALE

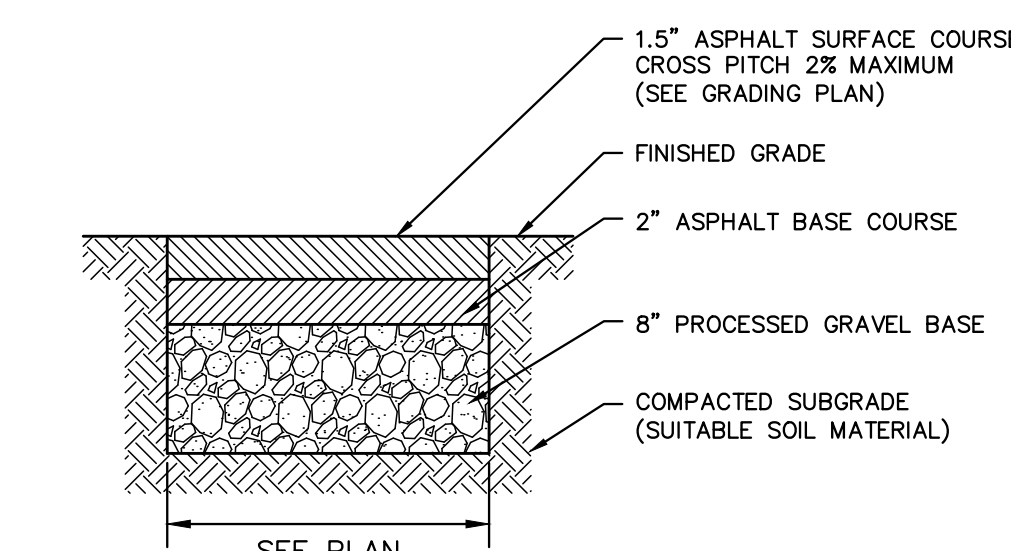

BITUMINOUS CONCRETE WALKWAY

NOT TO SCALE

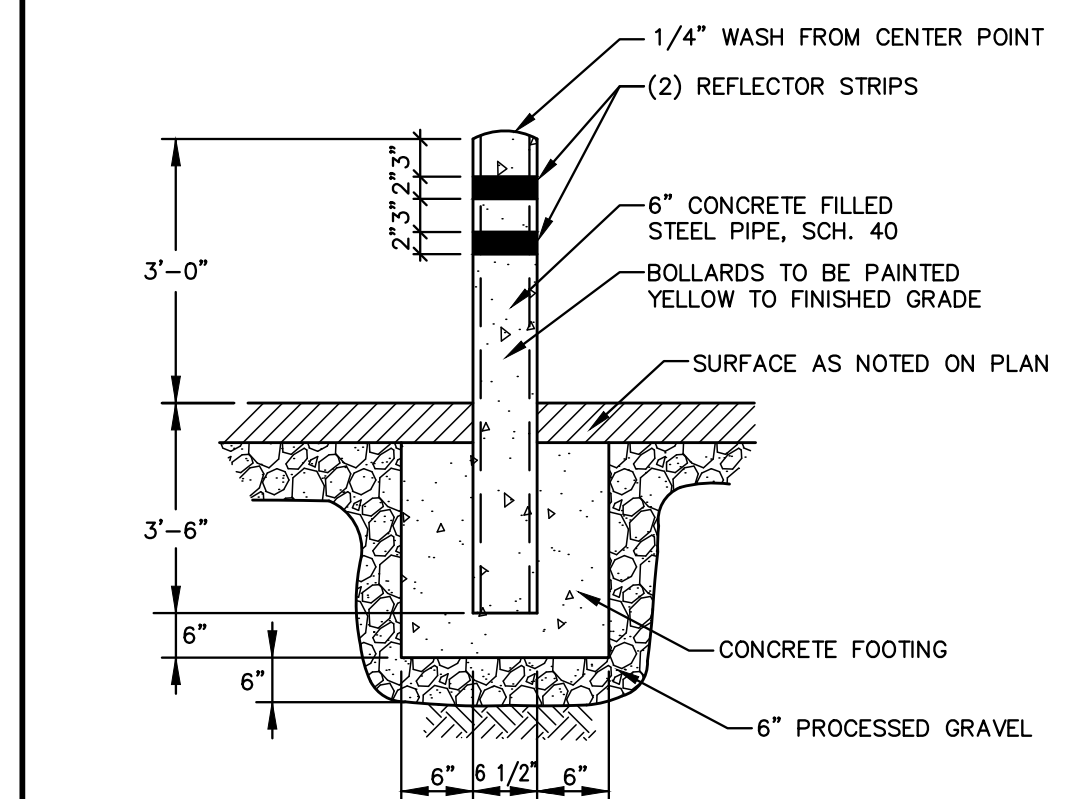

STEEL AND CONCRETE BOLLARD

NOT TO SCALE

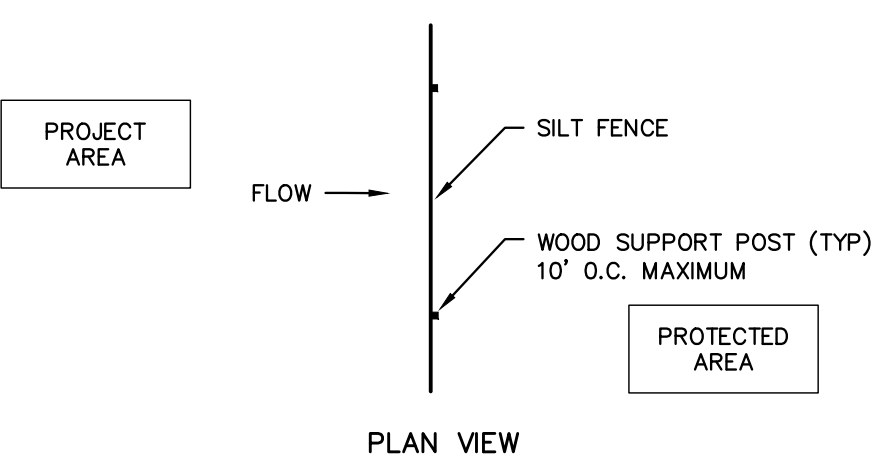

PLAN VIEW

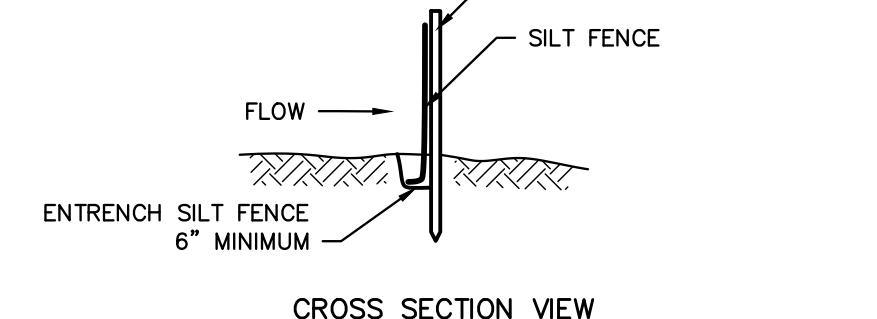

CROSS SECTION VIEW

SILT FENCE

NOT TO SCALE

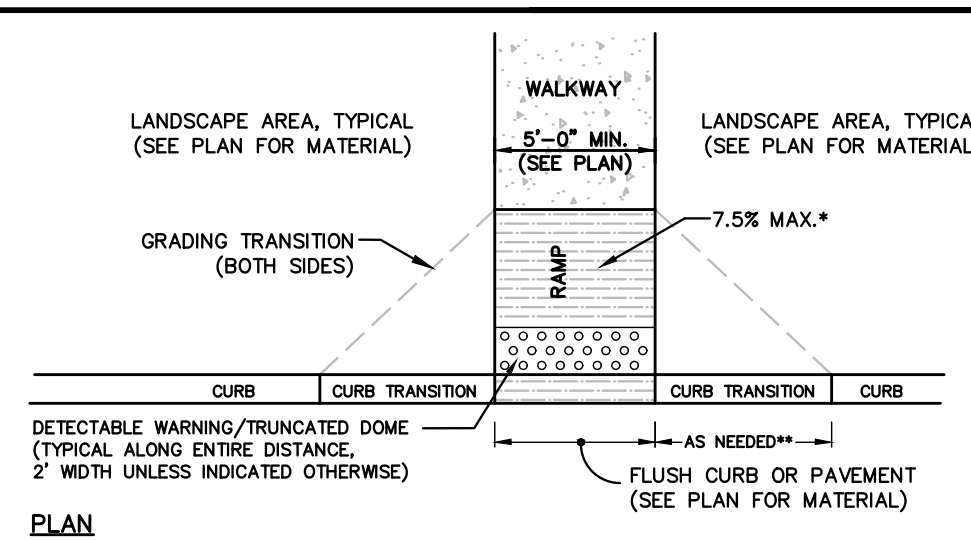

CURB RAMP (PERPENDICULAR)

NOT TO SCALE

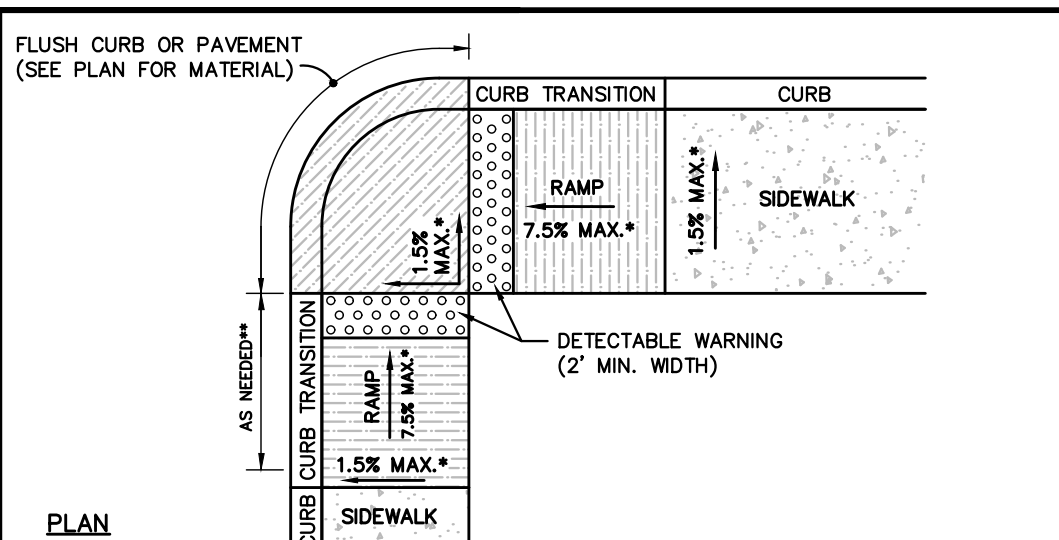

CURB RAMP AT RADIUS

NOT TO SCALE

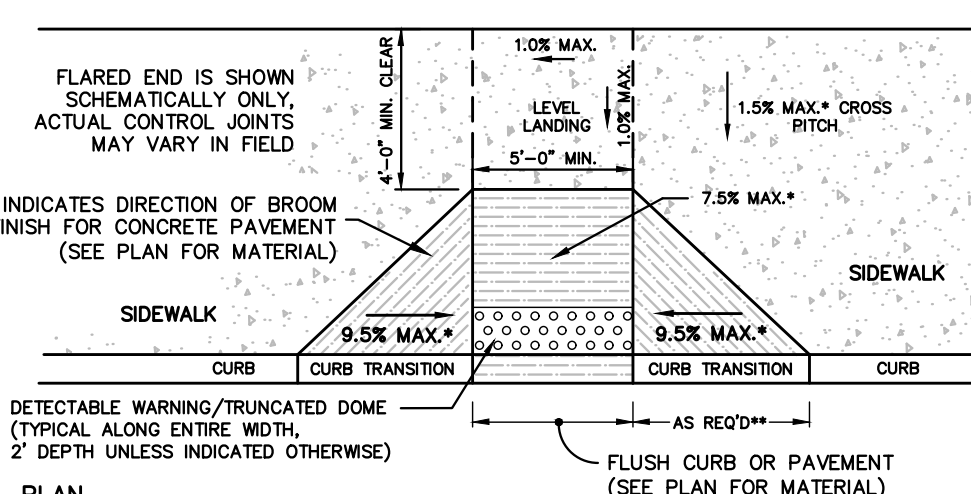

CURB RAMP WITH FLARED SIDES (ALONG SIDEWALK)

NOT TO SCALE

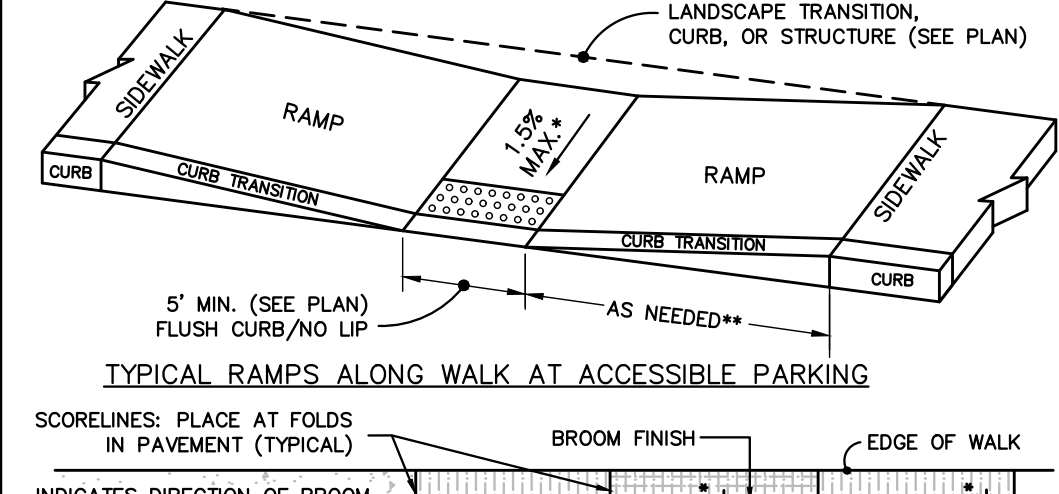

TYPICAL RAMP AT ACCESSIBLE PARKING

NOT TO SCALE

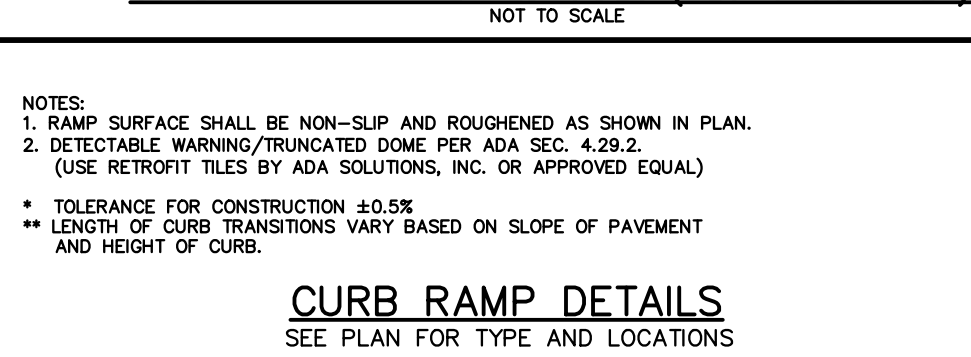

CURB RAMP DETAILS

SEE PLAN FOR TYPE AND LOCATIONS

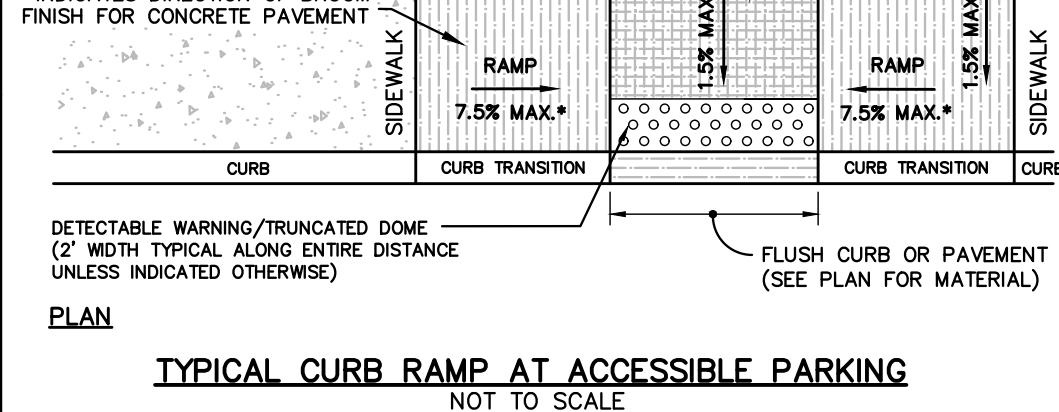

TYPICAL CURB RAMP AT ACCESSIBLE PARKING

NOT TO SCALE

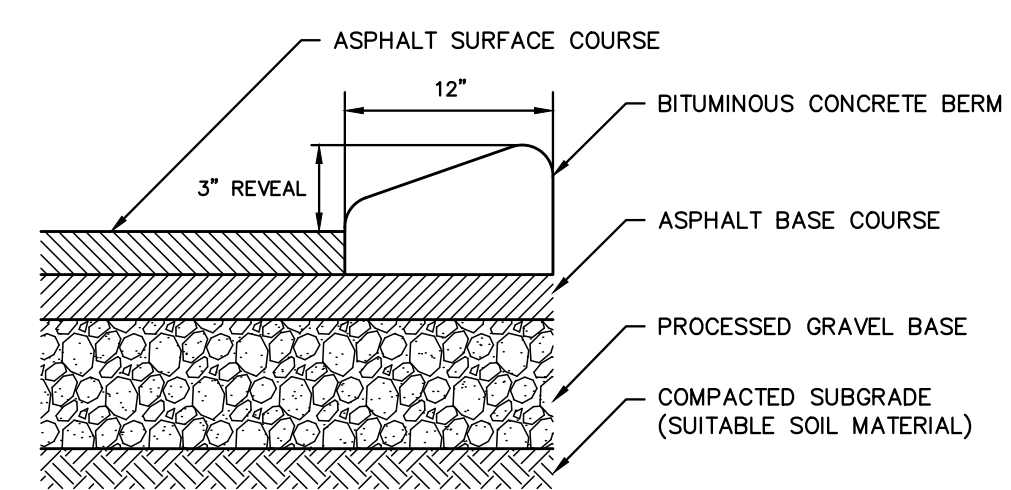

BITUMINOUS CONCRETE BERM

NOT TO SCALE

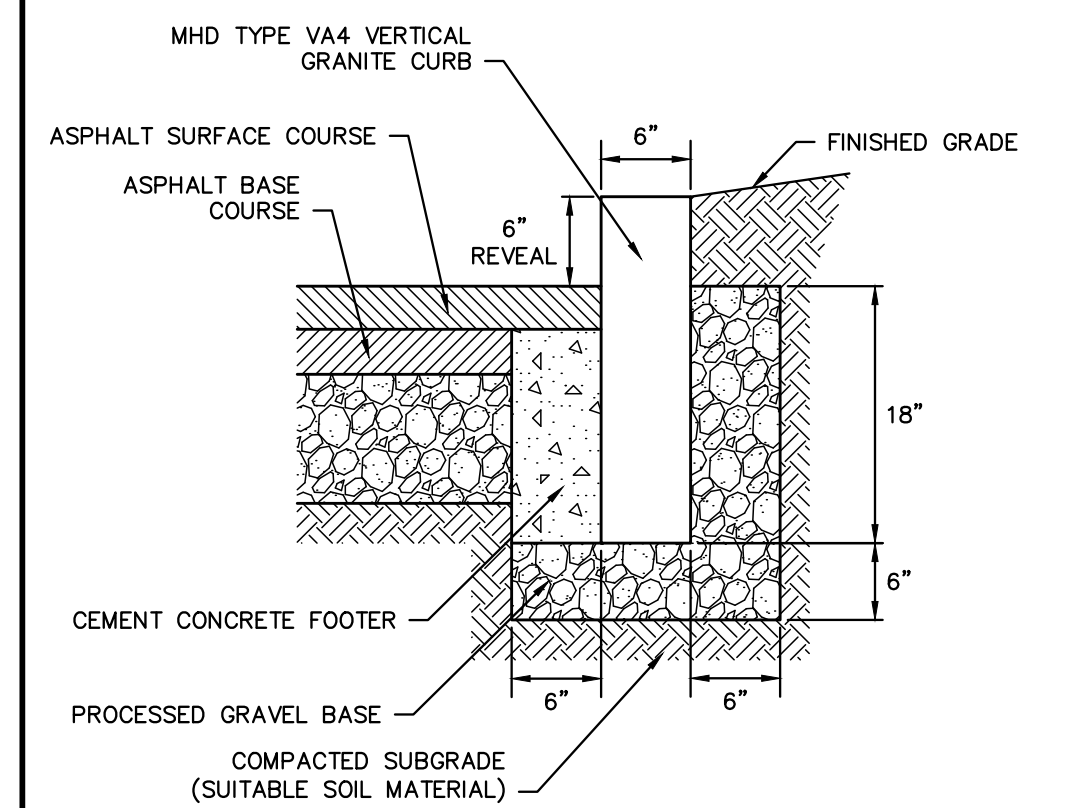

VERTICAL GRANITE CURB

NOT TO SCALE

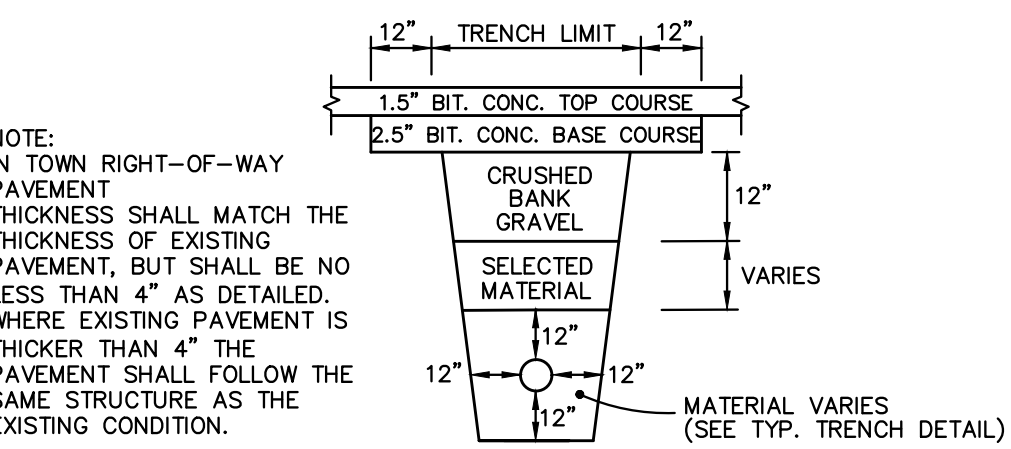

OVERLAY PAVEMENT

NOT TO SCALE

# HARBOR VUE

HYANNIS, MA

WinnDevelopment Company, LP

ARCHITECT



101 SUMMER ST BOSTON MA 02110

CONSULTANT



BEALS AND THOMAS, INC.  
144 Turnpike Road, Suite 210  
Southborough, Massachusetts 01772-2104  
T 508.366.0560 | www.bealsandthomas.com

STAMP



KEY PLAN

FOR PERMITTING ONLY

1	7/31/23	SITE PLAN REVIEW
MARK	DATE	DESCRIPTION

PROJECT NUMBER: 3447.00

DRAWN BY:

CHECKED BY:

SHEET TITLE

SITE DETAILS

SCALE: AS NOTED

C8.0

FOR NOTES, REFERENCES AND LEGEND SEE SHEET C1.0.

BEALS AND THOMAS, INC. SHALL NOT BE RESPONSIBLE FOR CONSTRUCTION MEANS, METHODS, TECHNIQUES, OR PROCEDURES UTILIZED BY THE CONTRACTOR, NOR FOR THE SAFETY OF PUBLIC OR CONTRACTOR'S EMPLOYEES; OR FOR THE FAILURE OF THE CONTRACTOR TO CARRY OUT THE WORK IN ACCORDANCE WITH THE CONTRACT DOCUMENTS.

NO PART OF THIS DOCUMENT MAY BE REPRODUCED, STORED IN A RETRIEVAL SYSTEM, OR TRANSMITTED IN ANY FORM OR BY ANY MEANS, ELECTRONIC, MECHANICAL, PHOTOCOPYING, RECORDING OR OTHERWISE WITHOUT THE PRIOR WRITTEN PERMISSION OF BEALS AND THOMAS, INC. EXCEPT THAT ANY REGULATORY AUTHORITY MAY REPRODUCE AND TRANSMIT COPIES AS REQUIRED IN CONJUNCTION WITH PERFORMANCE OF OFFICIAL BUSINESS UNDER ITS JURISDICTION. ANY MODIFICATIONS TO THIS DOCUMENT WITHOUT THE WRITTEN PERMISSION OF BEALS AND THOMAS, INC. SHALL RENDER IT INVALID AND UNUSABLE.

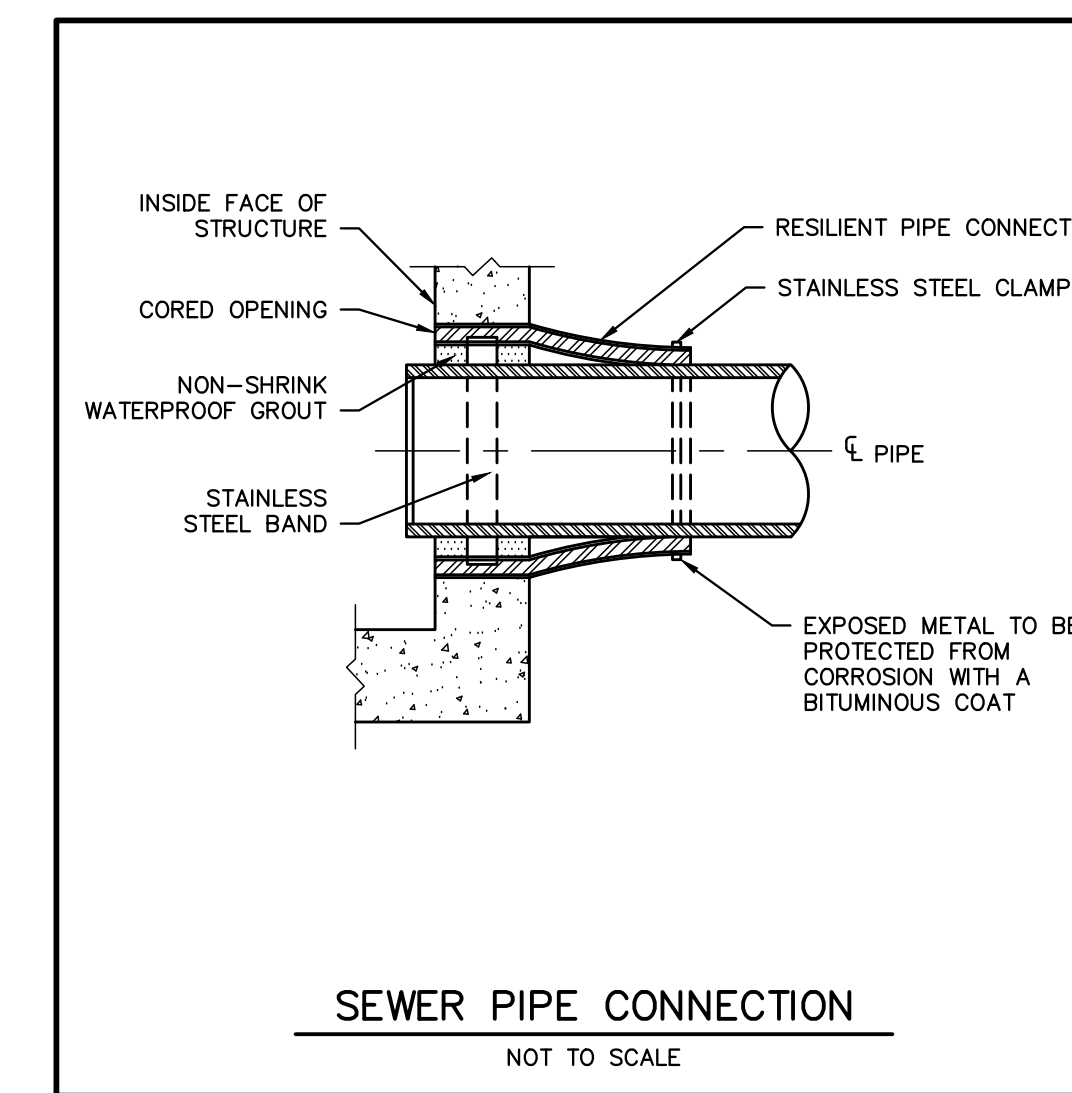
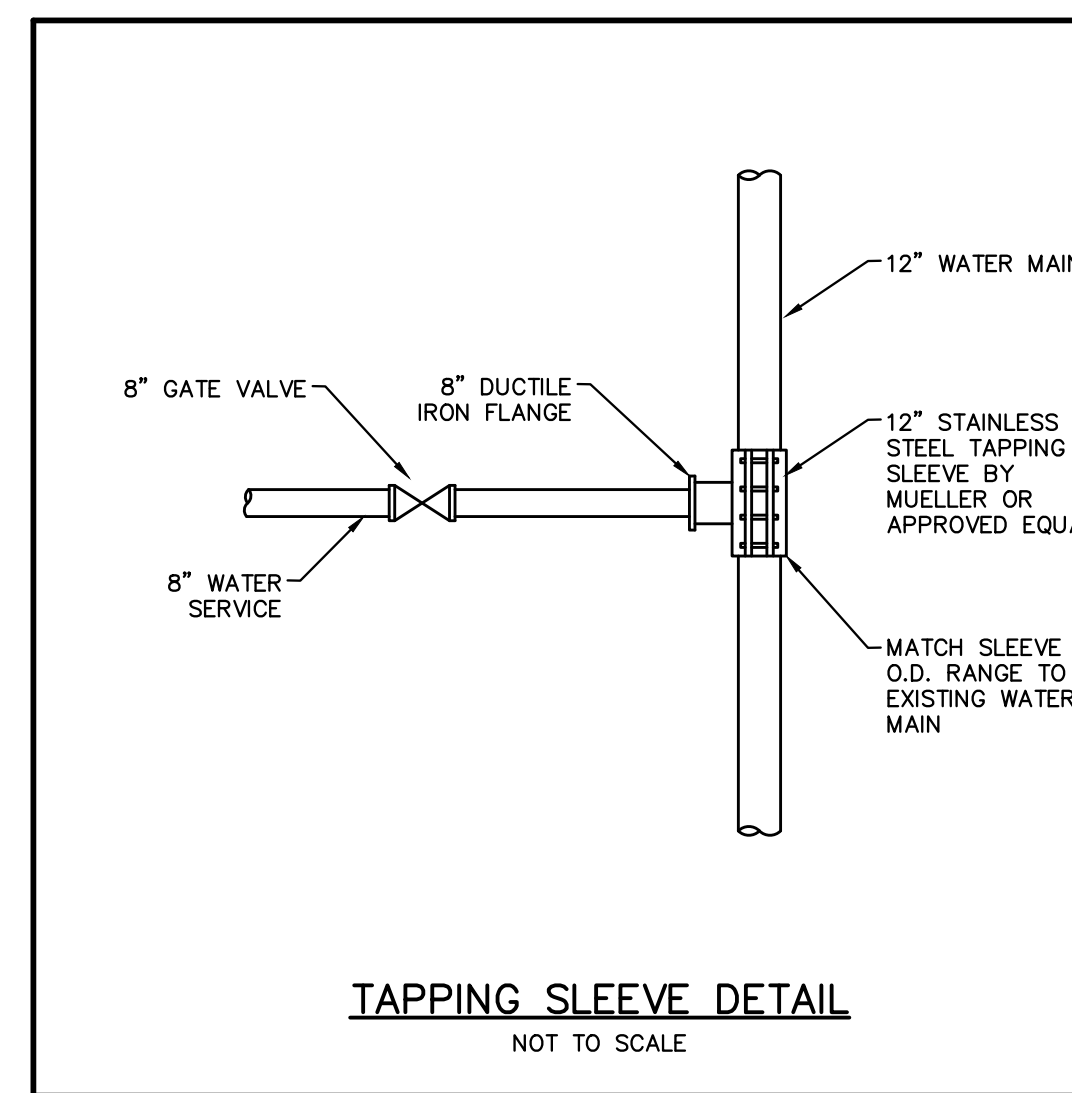
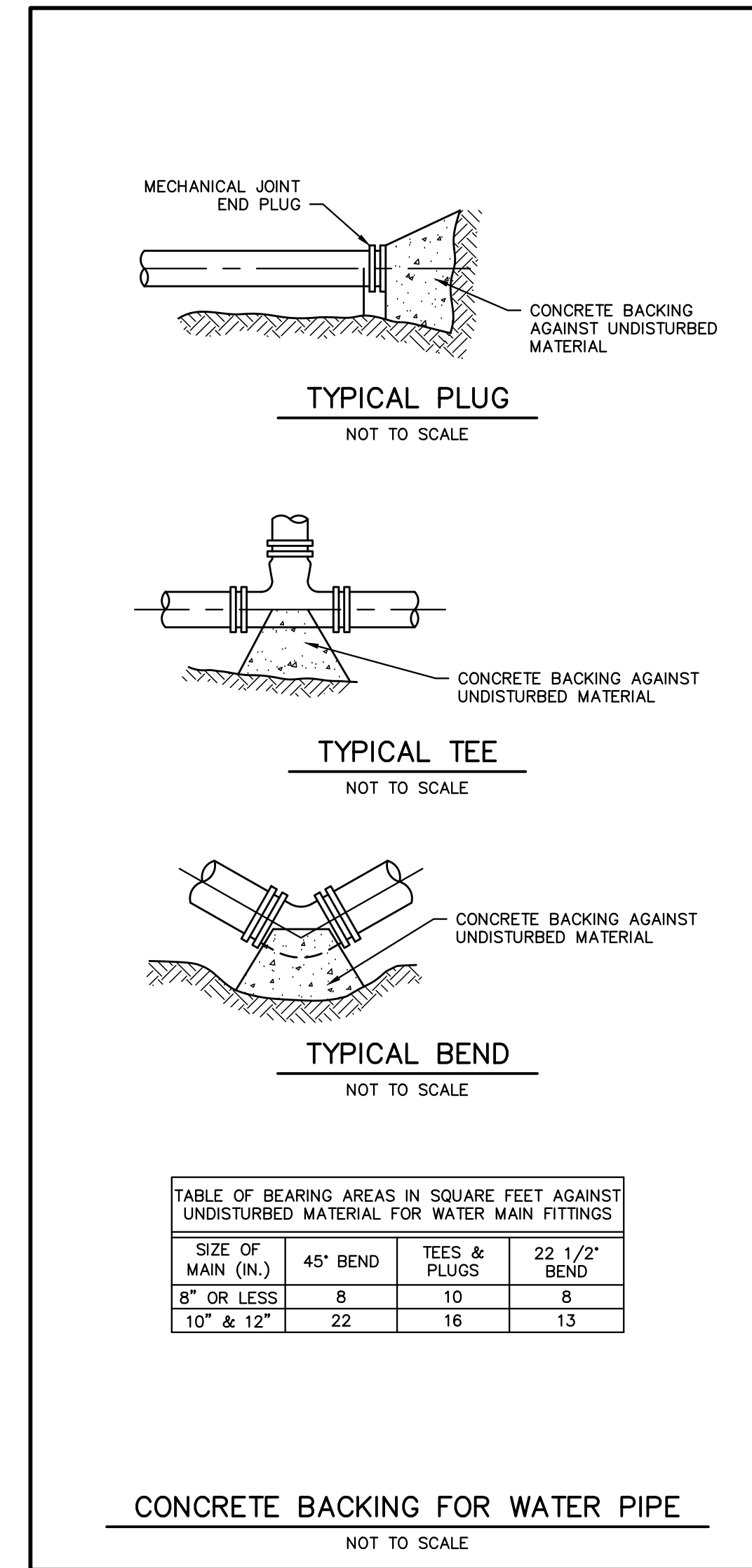
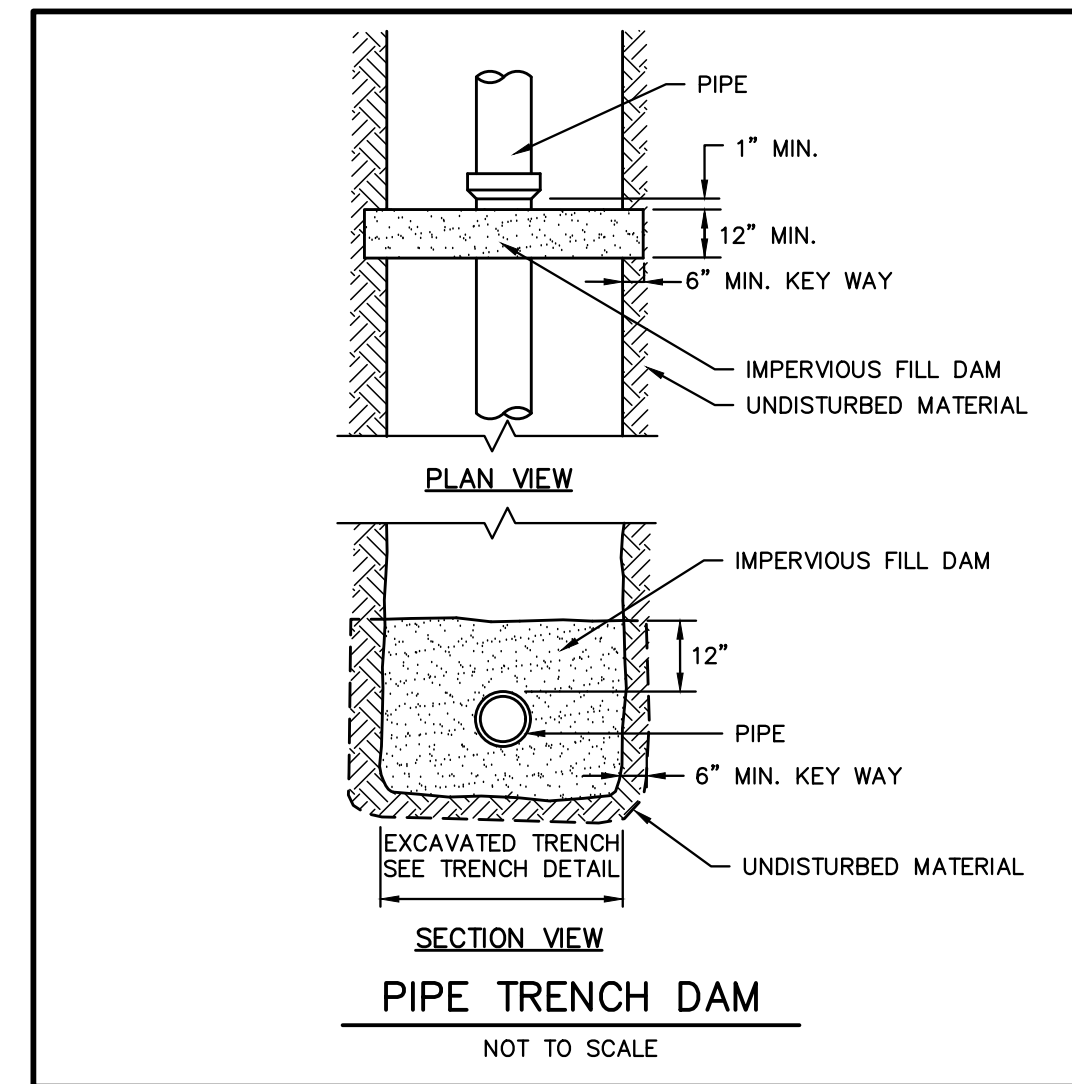
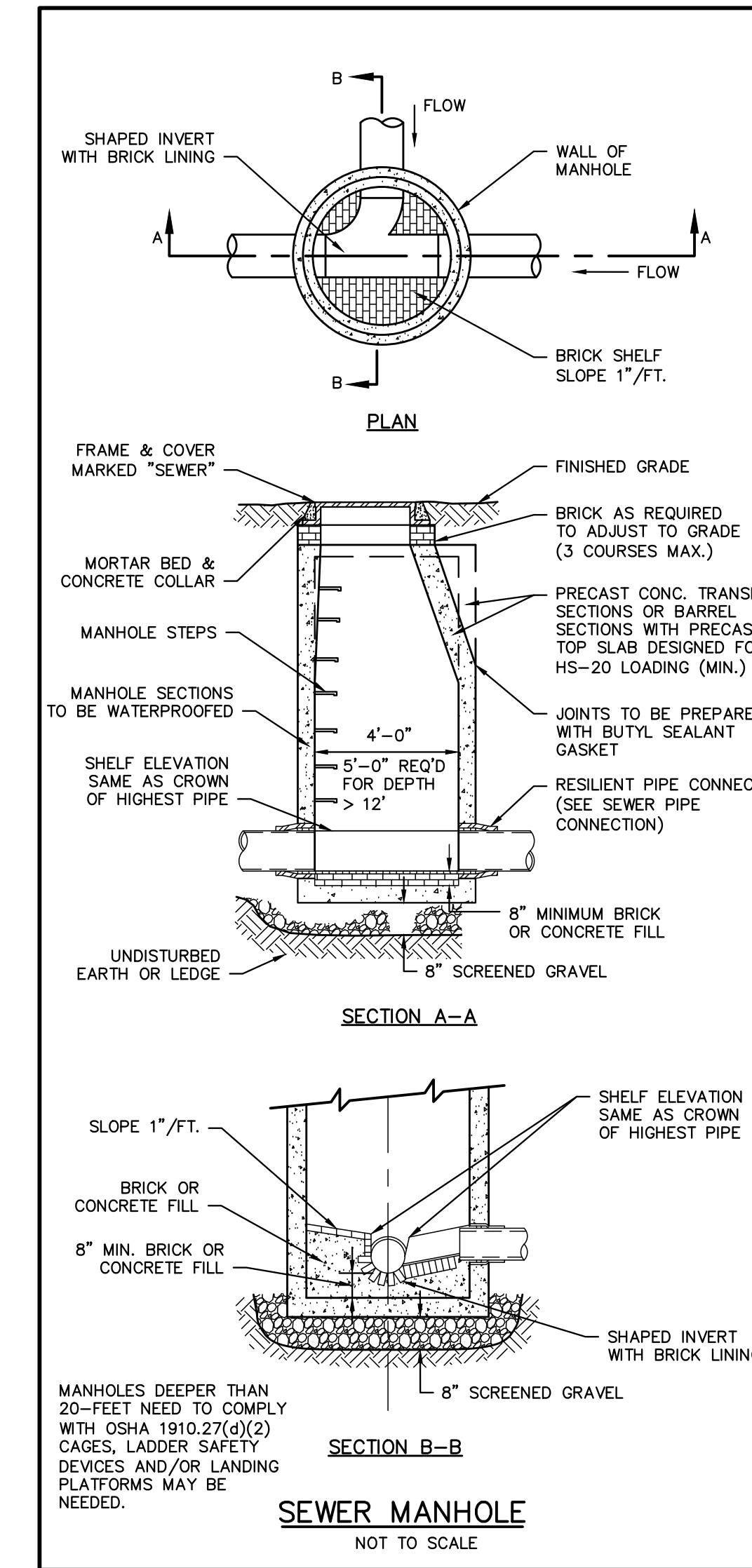
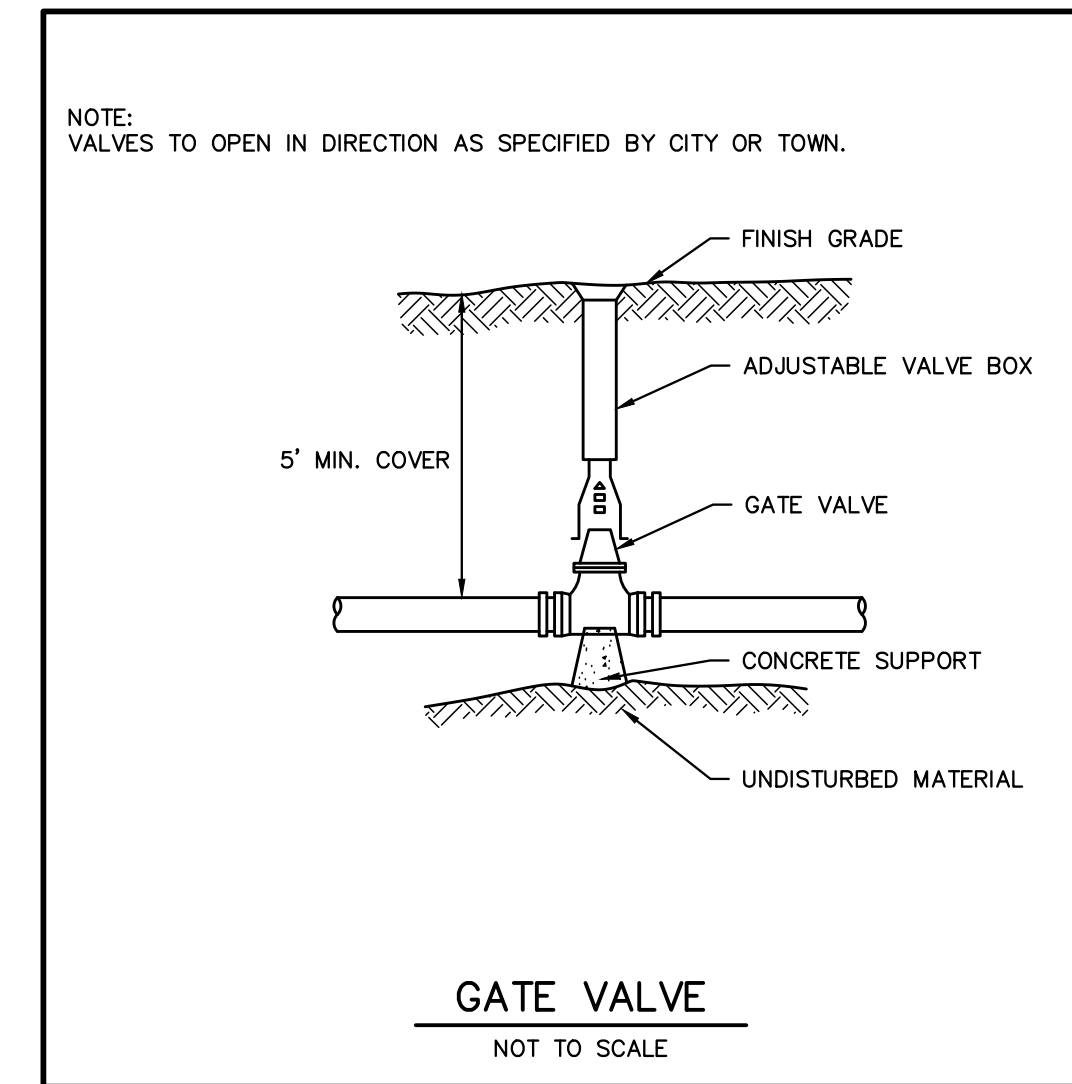
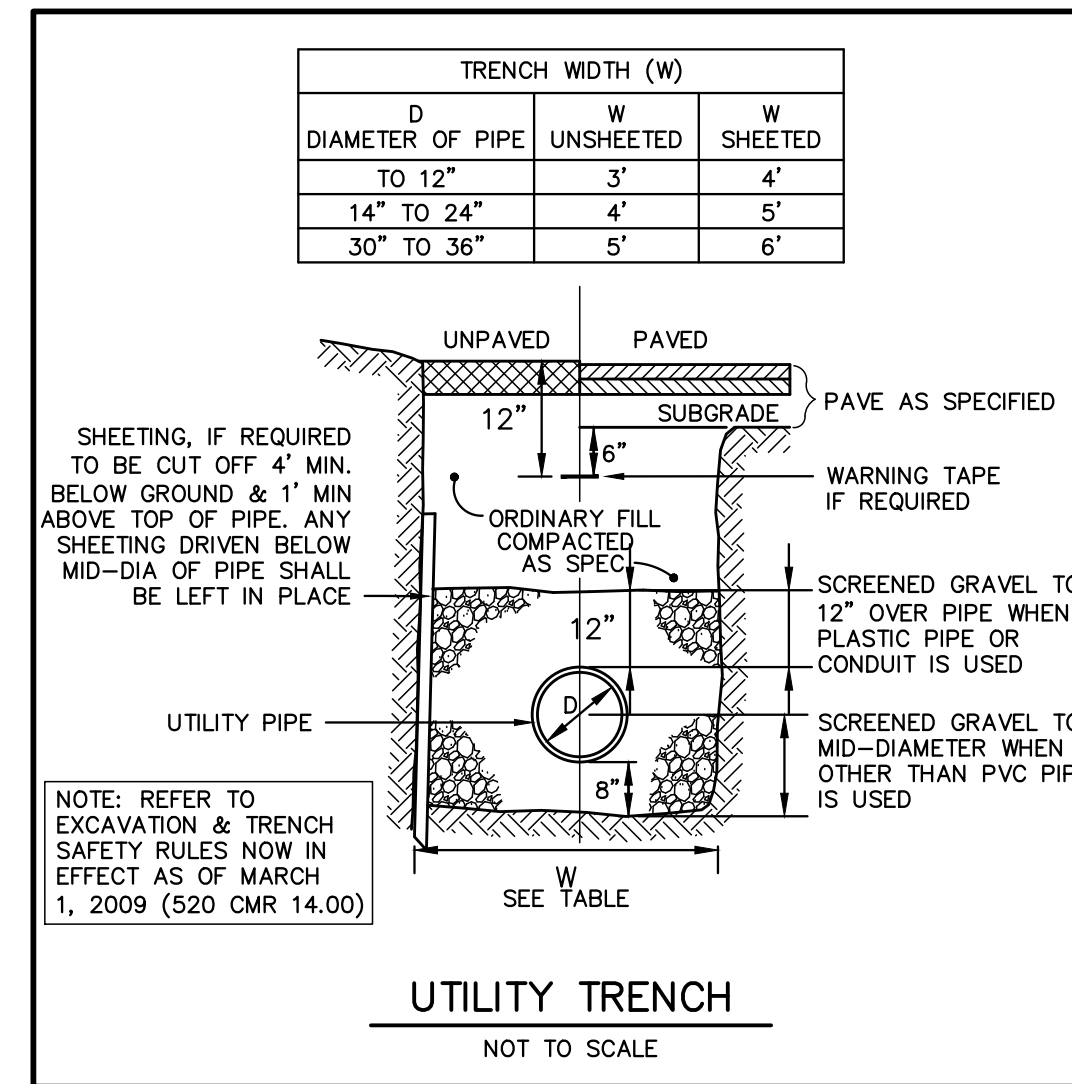
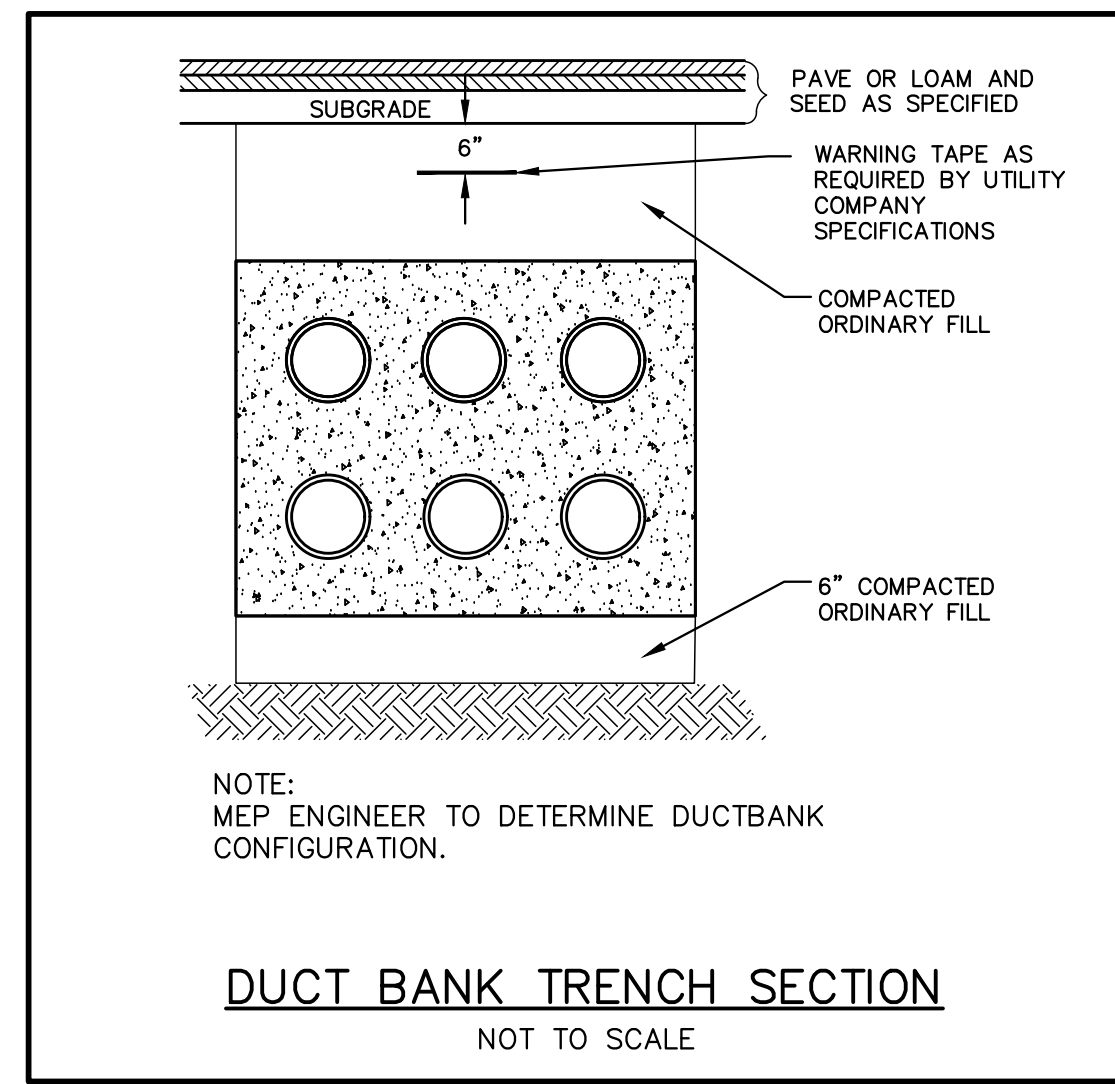

# HARBOR VUE

HYANNIS, MA

WinnDevelopment Company, LP

ARCHITECT

101 SUMMER ST BOSTON MA 02110

CONSULTANT

BEALS AND THOMAS, INC.  
144 Turnpike Road, Suite 210  
Southborough, Massachusetts 01772-2104  
T 508.366.0560 | www.bealsandthomas.com

STAMP

7/31/23

KEY PLAN

**FOR PERMITTING ONLY**

1	7/31/23	SITE PLAN REVIEW
MARK	DATE	DESCRIPTION

PROJECT NUMBER: 3447.00  
DRAWN BY:  
CHECKED BY:

SHEET TITLE

**SITE DETAILS**

SCALE: AS NOTED

**C8.1**

FOR NOTES, REFERENCES AND LEGEND SEE SHEET C1.0.  
BEALS AND THOMAS, INC. SHALL NOT BE RESPONSIBLE FOR CONSTRUCTION MEANS, METHODS, TECHNIQUES, OR PROCEDURES UTILIZED BY THE CONTRACTOR, NOR FOR THE SAFETY OF PUBLIC OR CONTRACTOR'S EMPLOYEES; OR FOR THE FAILURE OF THE CONTRACTOR TO CARRY OUT THE WORK IN ACCORDANCE WITH THE CONTRACT DOCUMENTS.  
NO PART OF THIS DOCUMENT MAY BE REPRODUCED, STORED IN A RETRIEVAL SYSTEM, OR TRANSMITTED IN ANY FORM OR BY ANY MEANS, ELECTRONIC, MECHANICAL, PHOTOCOPYING, RECORDING OR OTHERWISE WITHOUT THE PRIOR WRITTEN PERMISSION OF BEALS AND THOMAS, INC. EXCEPT THAT ANY REGULATORY AUTHORITY MAY REPRODUCE AND TRANSMIT COPIES AS REQUIRED IN CONJUNCTION WITH PERFORMANCE OF OFFICIAL BUSINESS UNDER ITS JURISDICTION. ANY MODIFICATIONS TO THIS DOCUMENT WITHOUT THE WRITTEN PERMISSION OF BEALS AND THOMAS, INC. SHALL RENDER IT INVALID AND UNUSABLE.

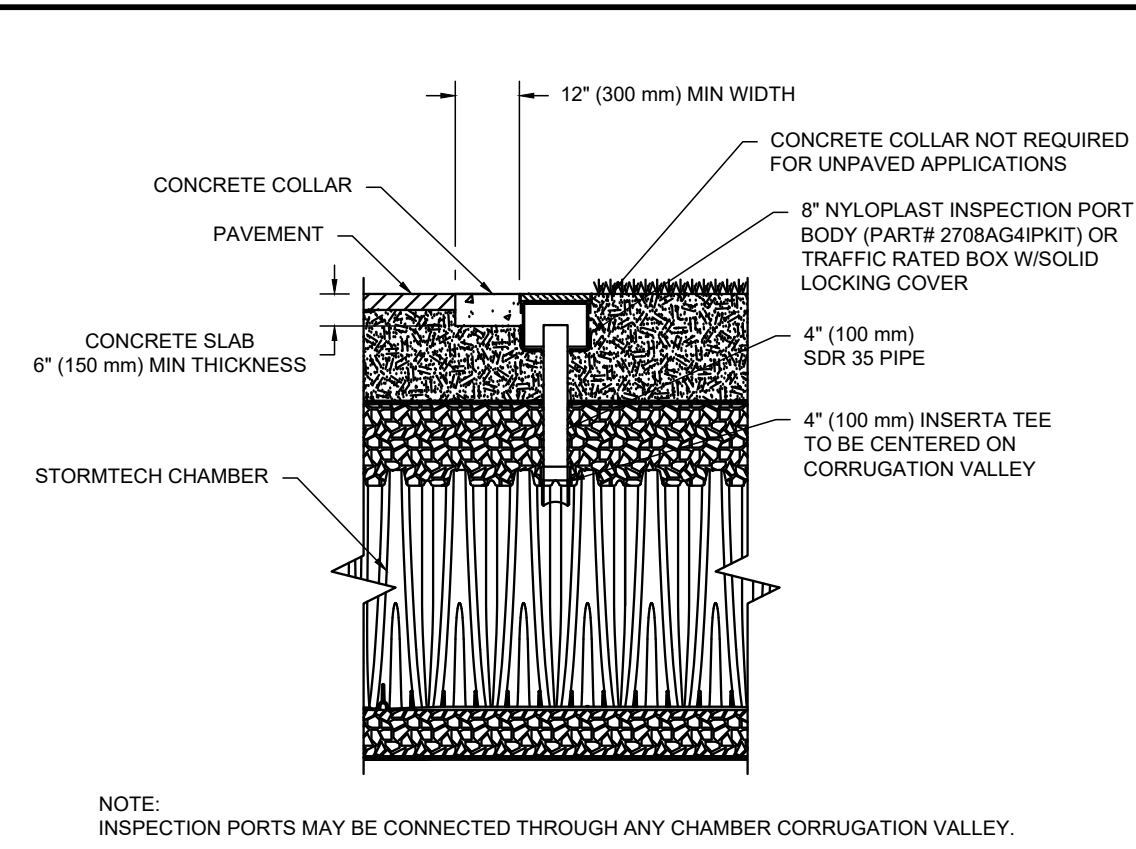
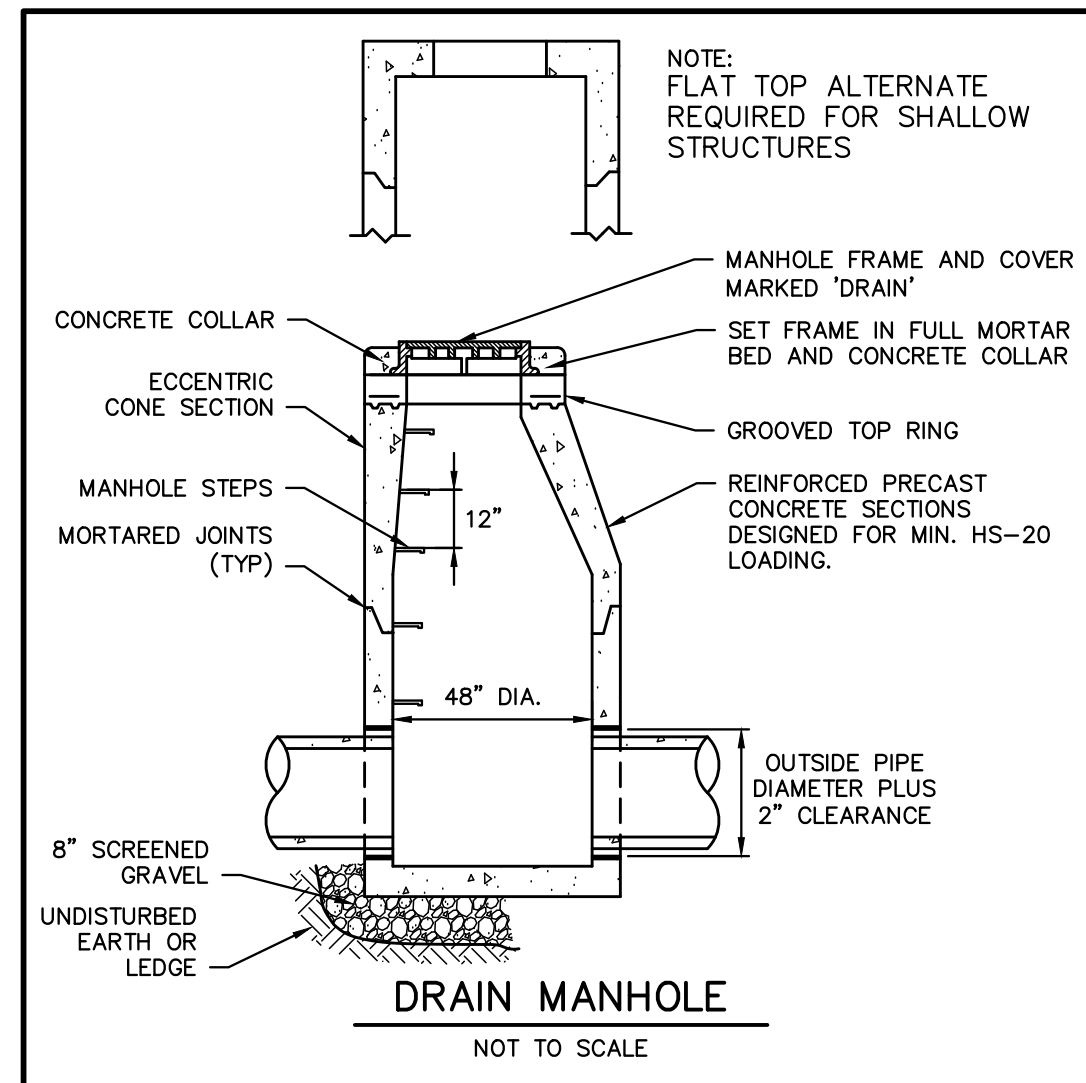
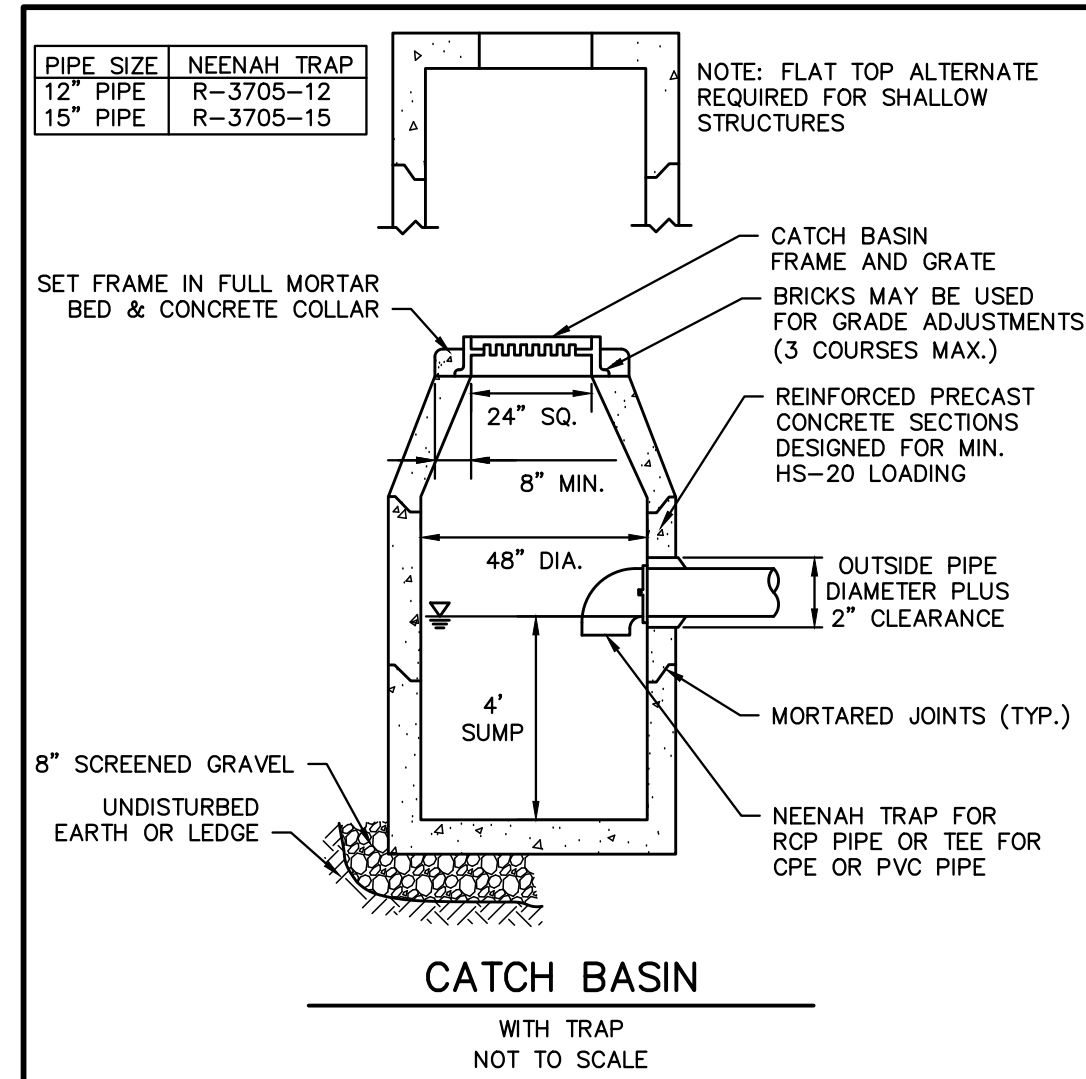

4" PVC INSPECTION PORT DETAIL (MC SERIES CHAMBER)

	NO. CHAMBERS	ROWS	BOTTOM OF STONE	BOT. OF CHAMBERS
SIS-1	51	3	24.0	24.75
SIS-2	6	2	24.75	25.50
SIS-3	6	2	18.00	18.75

**ACCEPTABLE FILL MATERIALS: STORMTECH MC-7200 CHAMBER SYSTEMS**

MATERIAL LOCATION	DESCRIPTION	AASHTO MATERIAL CLASSIFICATIONS	COMPACTION / DENSITY REQUIREMENT
D	<b>FINAL FILL:</b> FILL MATERIAL FOR LAYER 'D' STARTS FROM THE TOP OF THE 'C' LAYER TO THE BOTTOM OF FLEXIBLE PAVEMENT OR UNPAVED FINISHED GRADE ABOVE. NOTE THAT PAVEMENT SUBBASE MAY BE PART OF THE 'C' LAYER.	ANY SOIL/ROCK MATERIALS, NATIVE SOILS, OR PER ENGINEER'S PLANS. CHECK PLANS FOR PAVEMENT SUBGRADE REQUIREMENTS.	N/A
C	<b>INITIAL FILL:</b> FILL MATERIAL FOR LAYER 'C' STARTS FROM THE TOP OF THE EMBEDMENT STONE ('B' LAYER) TO 24" (600 mm) ABOVE THE TOP OF THE CHAMBER. NOTE THAT PAVEMENT SUBBASE MAY BE A PART OF THE 'C' LAYER.	GRANULAR WELL-GRADED SOIL/AGGREGATE MIXTURES, <35% FINES OR PROCESSED AGGREGATE. MOST PAVEMENT SUBBASE MATERIALS CAN BE USED IN LIEU OF THIS LAYER.	AASHTO M145 <sup>1</sup> A-1, A-2-4, A-3 OR AASHTO M43 <sup>2</sup> 3, 3S7, 4, 4E7, 5, 5E7, 6, 6E7, 6E8, 7, 7E8, 8, 8E9, 9, 10
B	<b>EMBEDMENT STONE:</b> FILL SURROUNDING THE CHAMBERS FROM THE FOUNDATION STONE ('A' LAYER) TO THE 'C' LAYER ABOVE.	CLEAN, CRUSHED, ANGULAR STONE	AASHTO M43 <sup>3</sup> 3, 4
A	<b>FOUNDATION STONE:</b> FILL BELOW CHAMBERS FROM THE SUBGRADE UP TO THE FOOT (BOTTOM) OF THE CHAMBER.	CLEAN, CRUSHED, ANGULAR STONE	AASHTO M43 <sup>3</sup> 3, 4

PLEASE NOTE:  
 1. THE LISTED AASHTO DESIGNATIONS ARE FOR GRADATIONS ONLY. THE STONE MUST ALSO BE CLEAN, CRUSHED, ANGULAR. FOR EXAMPLE, A SPECIFICATION FOR #4 STONE WOULD STATE: "CLEAN, CRUSHED, ANGULAR NO. 4 (AASHTO M43) STONE".  
 2. STORMTECH COMPACTION REQUIREMENTS ARE MET FOR 'A' LOCATION MATERIALS WHEN PLACED AND COMPACTED IN 9" (230 mm) MAX LIFTS USING TWO FULL COVERAGES WITH A VIBRATORY COMPACTOR.  
 3. WHERE INFILTRATION SURFACES MAY BE COMPROMISED BY COMPACTION, FOR STANDARD DESIGN LOAD CONDITIONS, A FLAT SURFACE MAY BE ACHIEVED BY RAKING OR DRAGGING WITHOUT COMPACTION EQUIPMENT. FOR SPECIAL LOAD DESIGNS, CONTACT STORMTECH FOR COMPACTION REQUIREMENTS.  
 4. ONCE LAYER 'C' IS PLACED, ANY SOIL/MATERIAL CAN BE PLACED IN LAYER 'D' UP TO THE FINISHED GRADE. MOST PAVEMENT SUBBASE SOILS CAN BE USED TO REPLACE THE MATERIAL REQUIREMENTS OF LAYER 'C' OR 'D' AT THE SITE DESIGN ENGINEER'S DISCRETION.

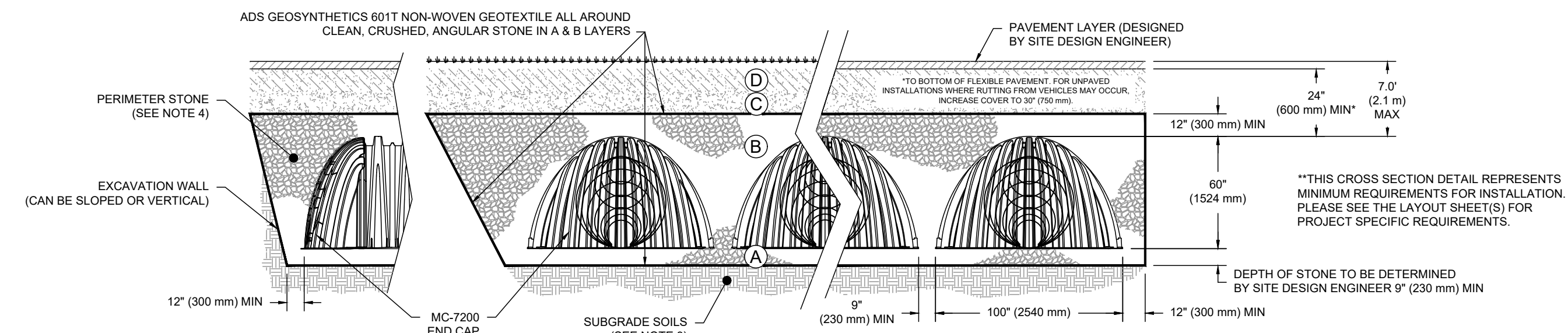

**NOTES:**

- CHAMBERS SHALL MEET THE REQUIREMENTS OF ASTM F2418, "STANDARD SPECIFICATION FOR POLYPROPYLENE (PP) CORRUGATED WALL STORMWATER COLLECTION CHAMBERS" CHAMBER CLASSIFICATION 60x101
- MC-7200 CHAMBERS SHALL BE DESIGNED IN ACCORDANCE WITH ASTM F2787 "STANDARD PRACTICE FOR STRUCTURAL DESIGN OF THERMOPLASTIC CORRUGATED WALL STORMWATER COLLECTION CHAMBERS".
- THE SITE DESIGN ENGINEER IS RESPONSIBLE FOR ASSESSING THE BEARING RESISTANCE (ALLOWABLE BEARING CAPACITY) OF THE SUBGRADE SOILS AND THE DEPTH OF FOUNDATION STONE WITH CONSIDERATION FOR THE RANGE OF EXPECTED SOIL MOISTURE CONDITIONS.
- PERIMETER STONE MUST BE EXTENDED HORIZONTALLY TO THE EXCAVATION WALL FOR BOTH VERTICAL AND SLOPED EXCAVATION WALLS.
  - TO MAINTAIN THE WIDTH OF CHAMBERS DURING SHIPPING AND HANDLING, CHAMBERS SHALL HAVE INTEGRAL, INTERLOCKING STACKING LUGS.
  - TO ENSURE A SECURE JOINT DURING INSTALLATION AND BACKFILL, THE HEIGHT OF THE CHAMBER JOINT SHALL NOT BE LESS THAN 3".
  - TO ENSURE THE INTEGRITY OF THE ARCH SHAPE DURING INSTALLATION, a) THE ARCH STIFFNESS CONSTANT AS DEFINED IN SECTION 6.2.8 OF ASTM F2418 SHALL BE GREATER THAN OR EQUAL TO 500 LBS/FT<sup>2</sup> AND b) TO RESIST CHAMBER DEFORMATION DURING INSTALLATION AT ELEVATED TEMPERATURES (ABOVE 73° F / 23° C), CHAMBERS SHALL BE PRODUCED FROM REFLECTIVE GOLD OR YELLOW COLORS.

INFILTRATION SYSTEMS  
NOT TO SCALE

MC-7200 CROSS SECTION DETAIL

HARBOR VUE  
HYANNIS, MA

WinnDevelopment Company, LP

ARCHITECT

**ICON**  
ARCHITECTURE

101 SUMMER ST BOSTON MA 02110

CONSULTANT

**BEALS AND THOMAS**

BEALS AND THOMAS, INC.  
144 Turnpike Road, Suite 210  
Southborough, Massachusetts 01772-2104  
T 508.366.0560 | www.bealsandthomas.com

STAMP



KEY PLAN

FOR PERMITTING ONLY

1	7/31/23	SITE PLAN REVIEW
MARK	DATE	DESCRIPTION

PROJECT NUMBER: 3447.00

DRAWN BY:

CHECKED BY:

SHEET TITLE

SITE DETAILS

SCALE: AS NOTED

C8.2

FOR NOTES, REFERENCES AND LEGEND SEE SHEET C1.0.

BEALS AND THOMAS, INC. SHALL NOT BE RESPONSIBLE FOR CONSTRUCTION MEANS, METHODS, TECHNIQUES, OR PROCEDURES UTILIZED BY THE CONTRACTOR, NOR FOR THE SAFETY OF PUBLIC OR CONTRACTOR'S EMPLOYEES; OR FOR THE FAILURE OF THE CONTRACTOR TO CARRY OUT THE WORK IN ACCORDANCE WITH THE CONTRACT DOCUMENTS.

NO PART OF THIS DOCUMENT MAY BE REPRODUCED, STORED IN A RETRIEVAL SYSTEM, OR TRANSMITTED IN ANY FORM OR BY ANY MEANS, ELECTRONIC, MECHANICAL, PHOTOCOPIING, RECORDING OR OTHERWISE WITHOUT THE PRIOR WRITTEN PERMISSION OF BEALS AND THOMAS, INC. EXCEPT THAT ANY REGULATORY AUTHORITY MAY REPRODUCE AND TRANSMIT COPIES AS REQUIRED IN CONJUNCTION WITH PERFORMANCE OF OFFICIAL BUSINESS UNDER ITS JURISDICTION. ANY MODIFICATIONS TO THIS DOCUMENT WITHOUT THE WRITTEN PERMISSION OF BEALS AND THOMAS, INC. SHALL RENDER IT INVALID AND UNUSABLE.

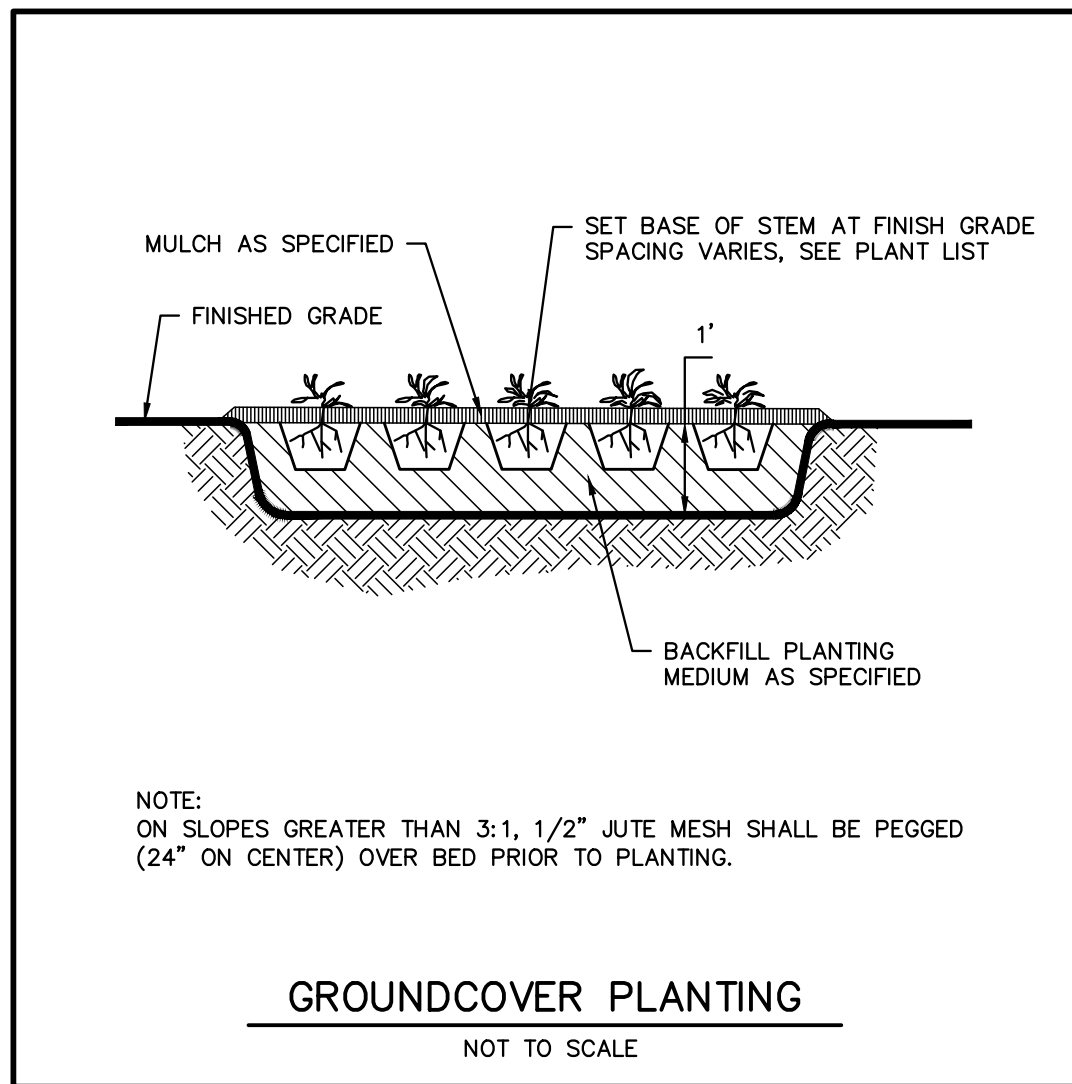
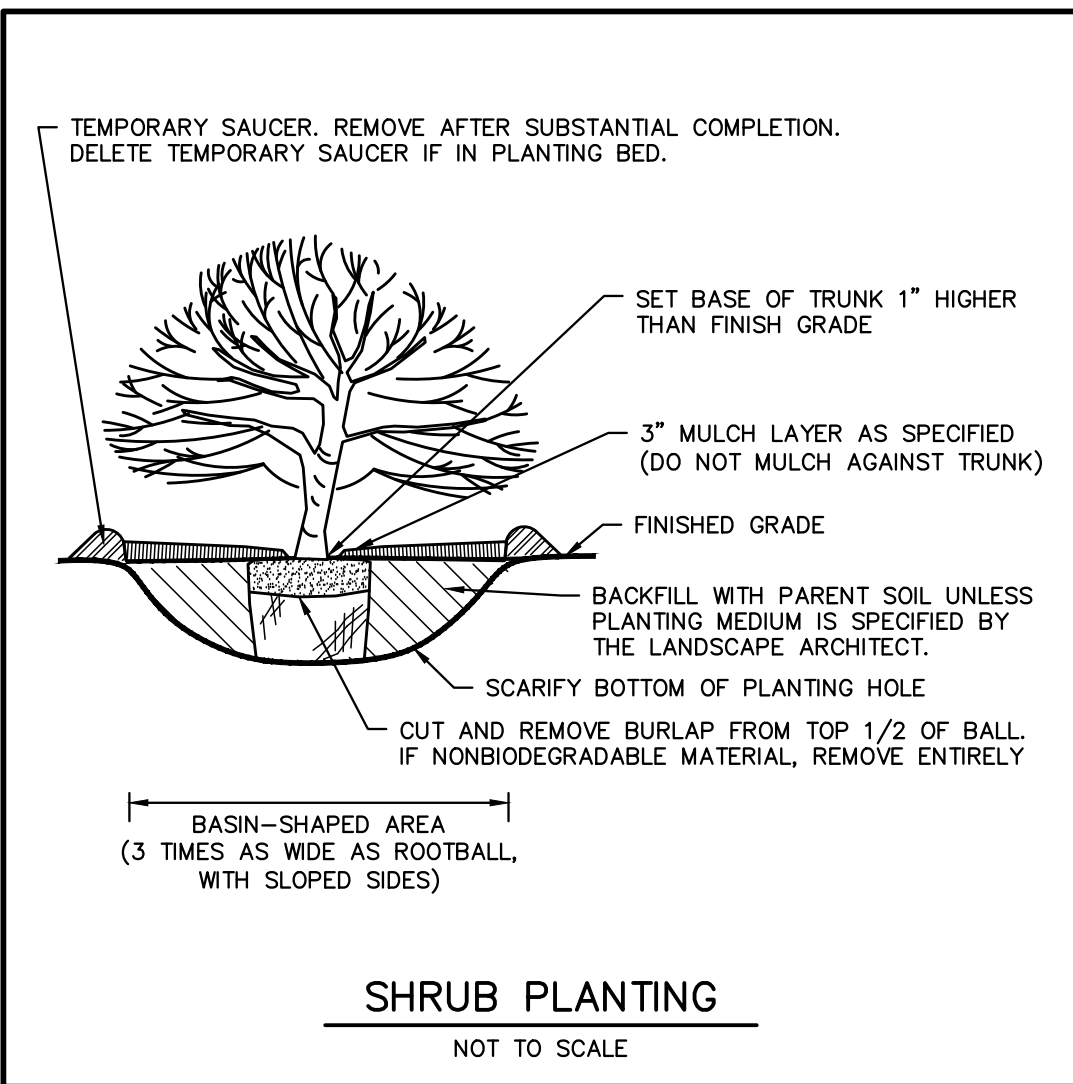
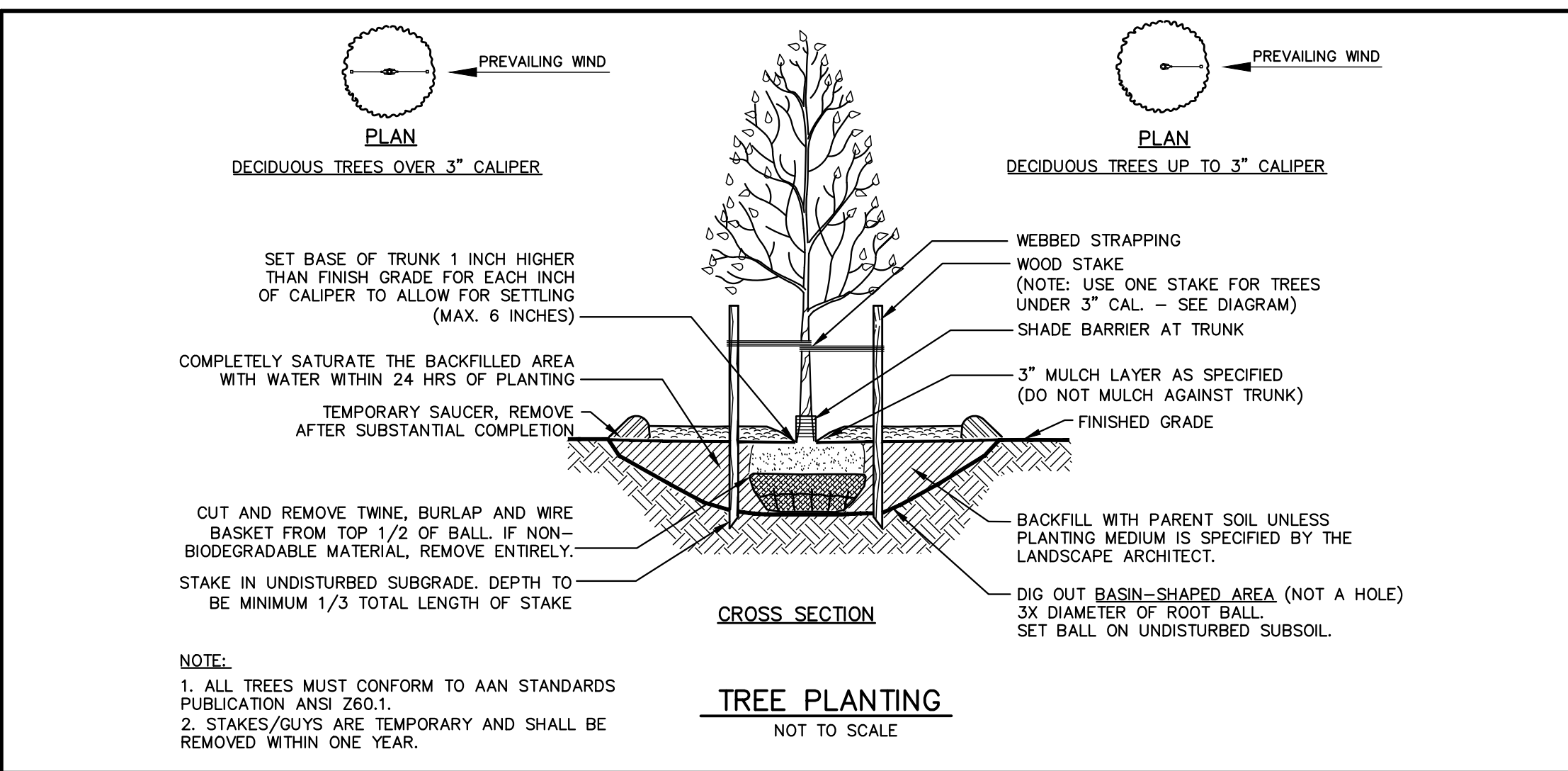
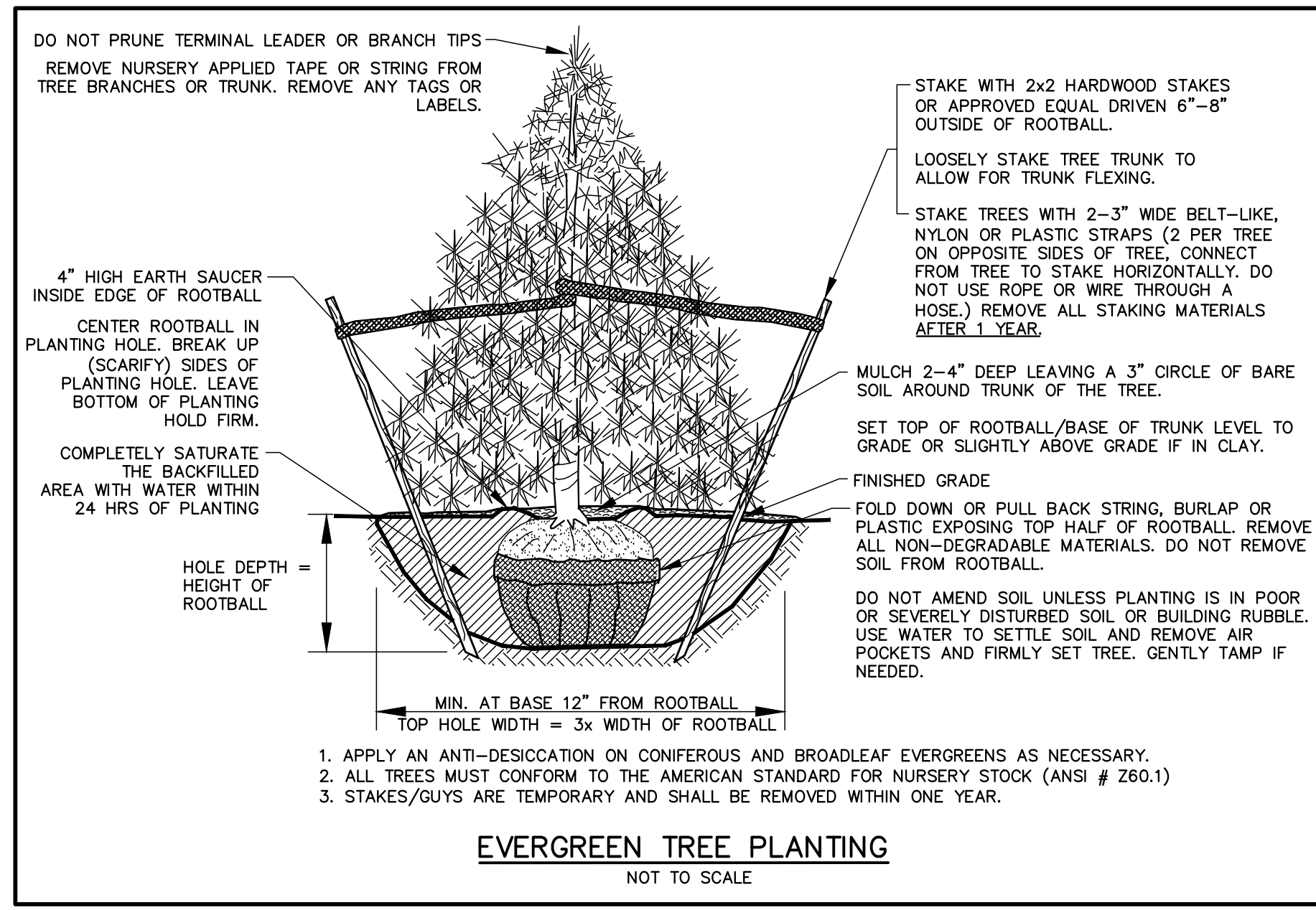
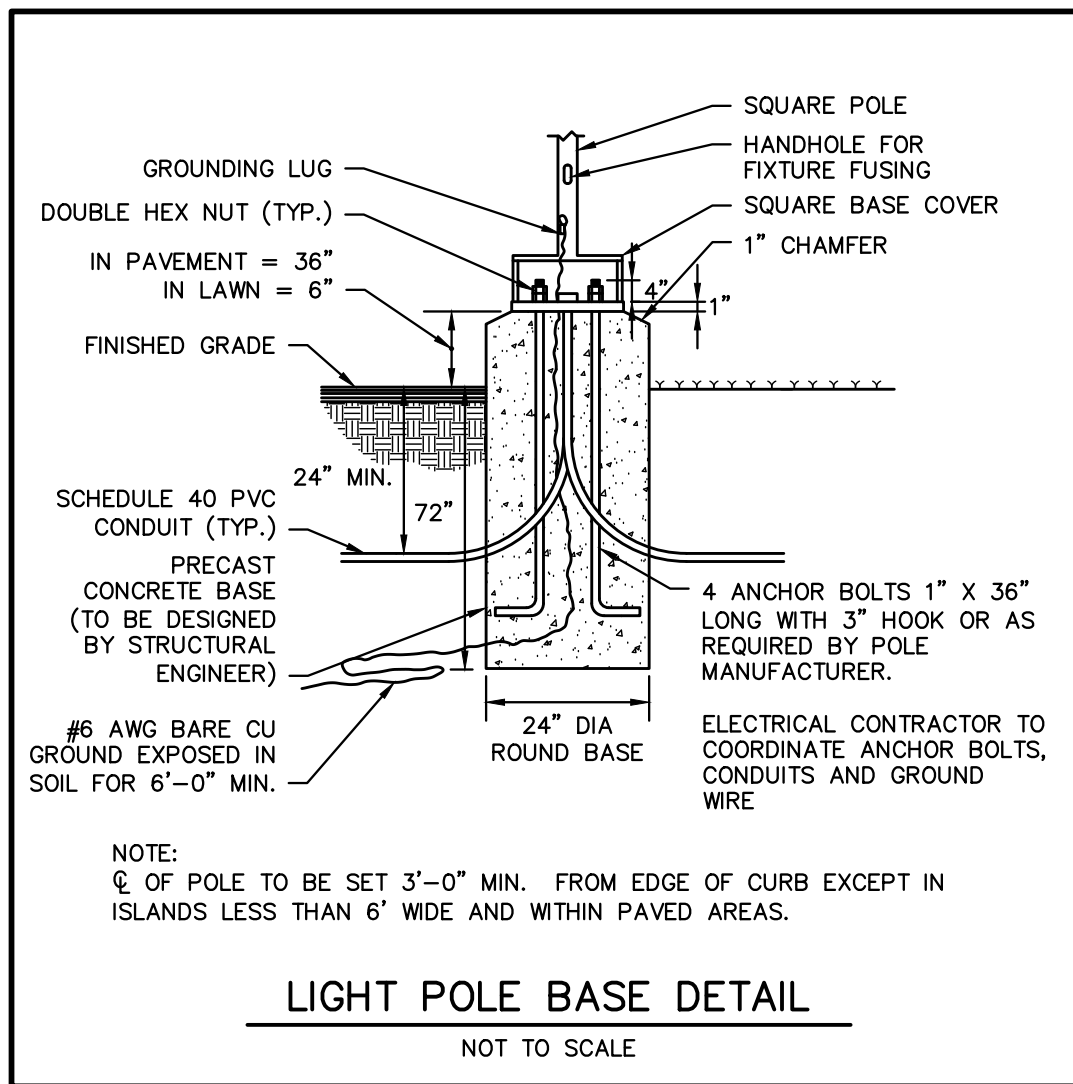
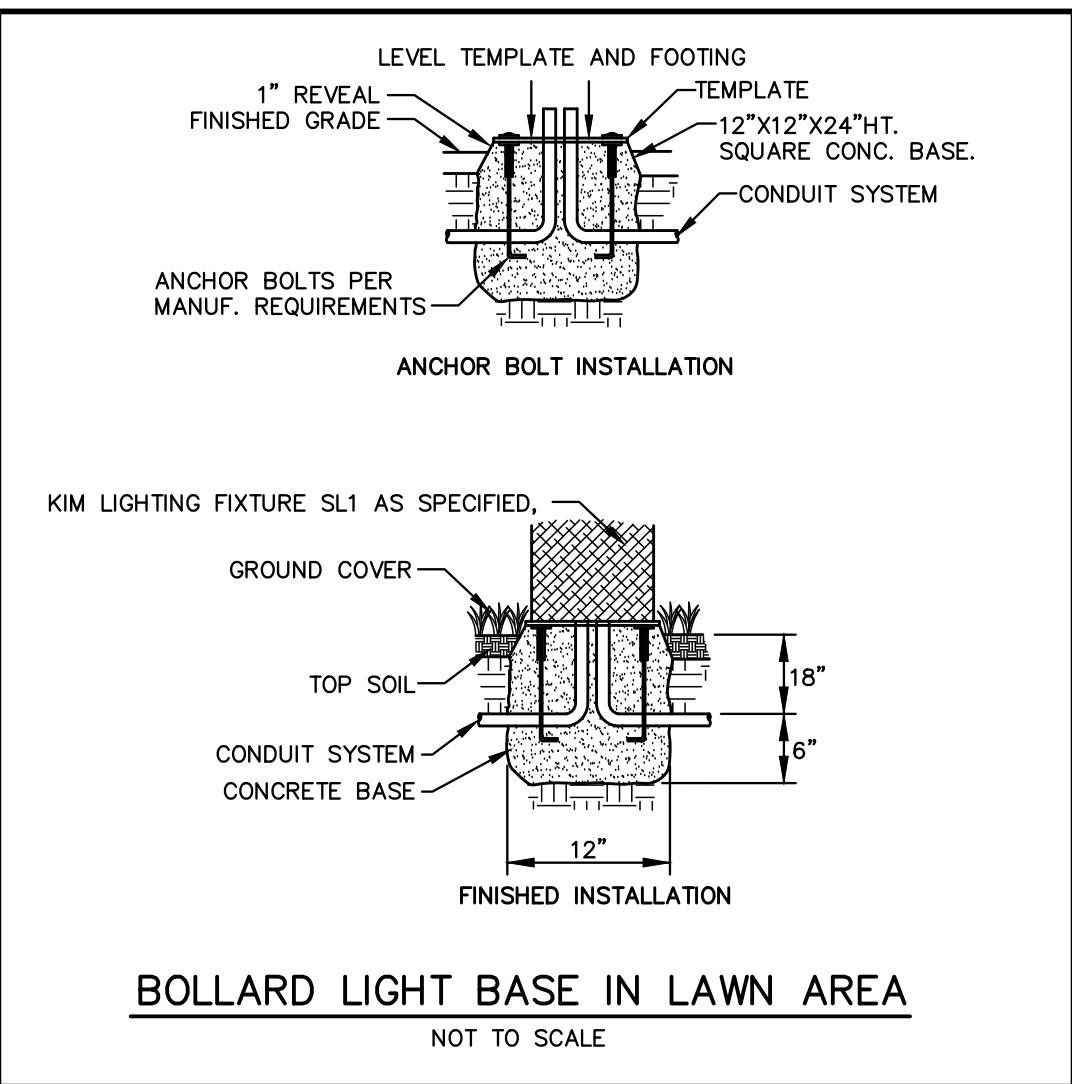
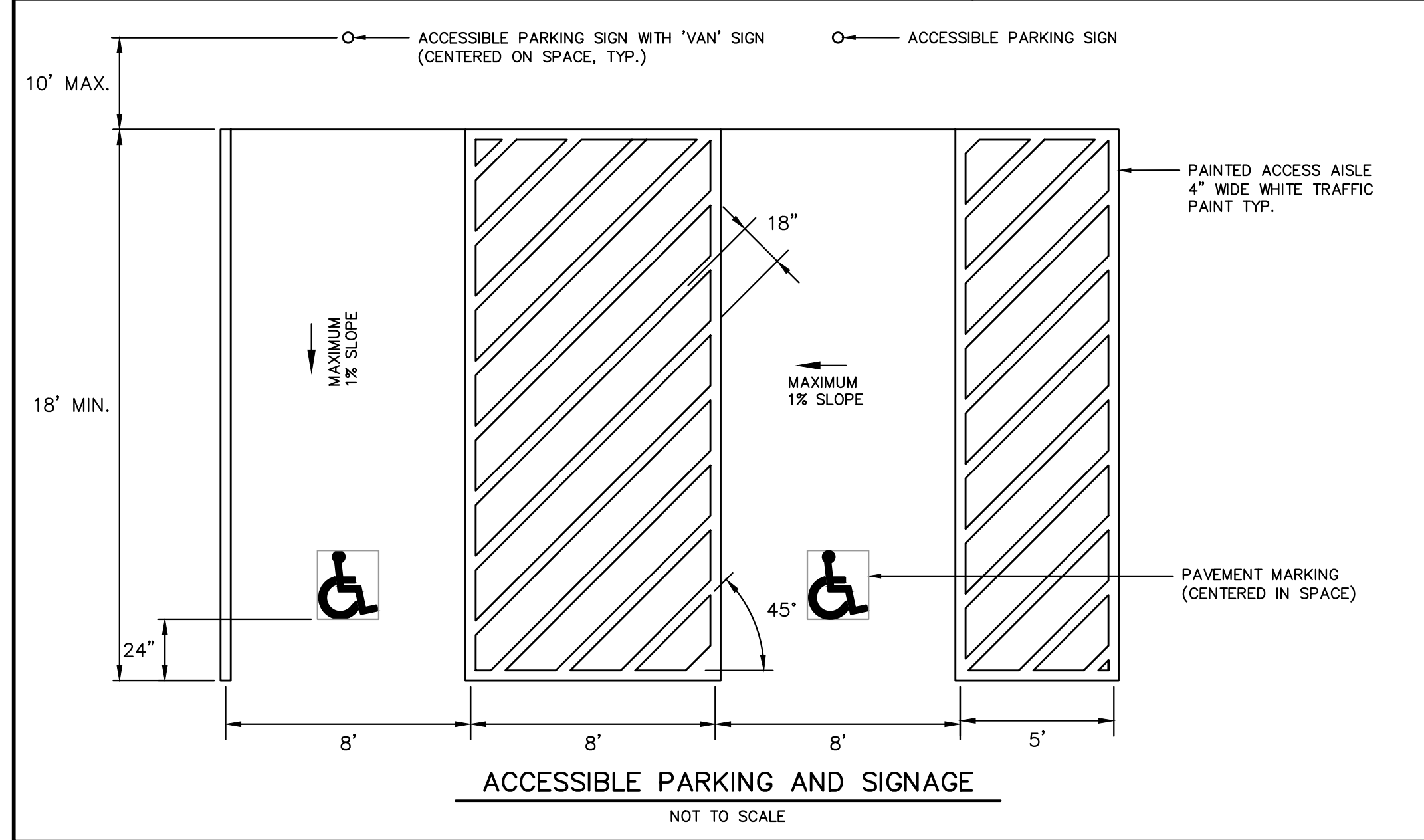
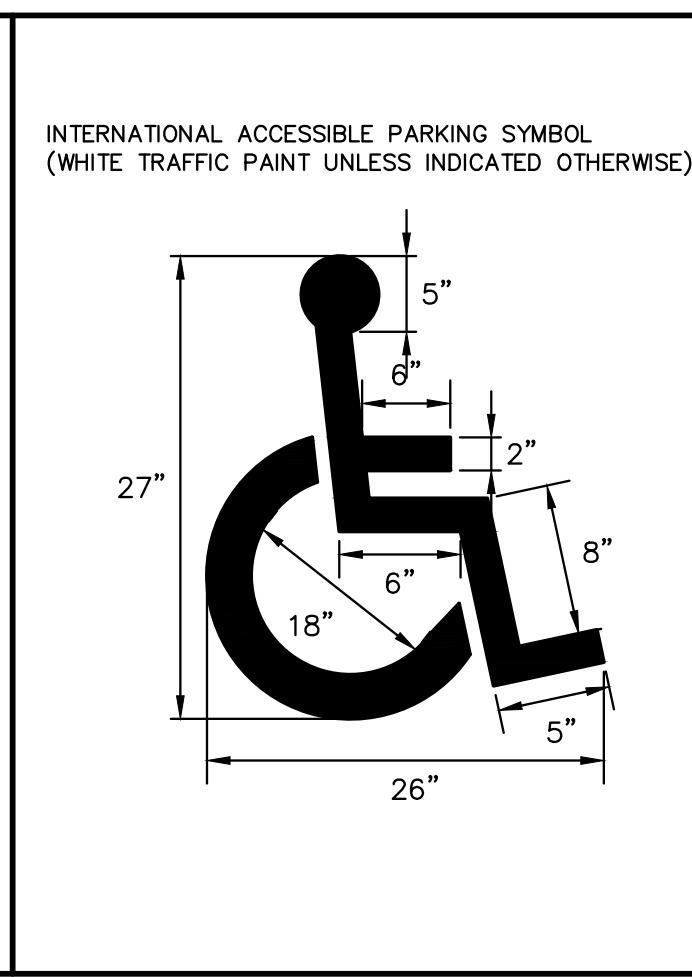
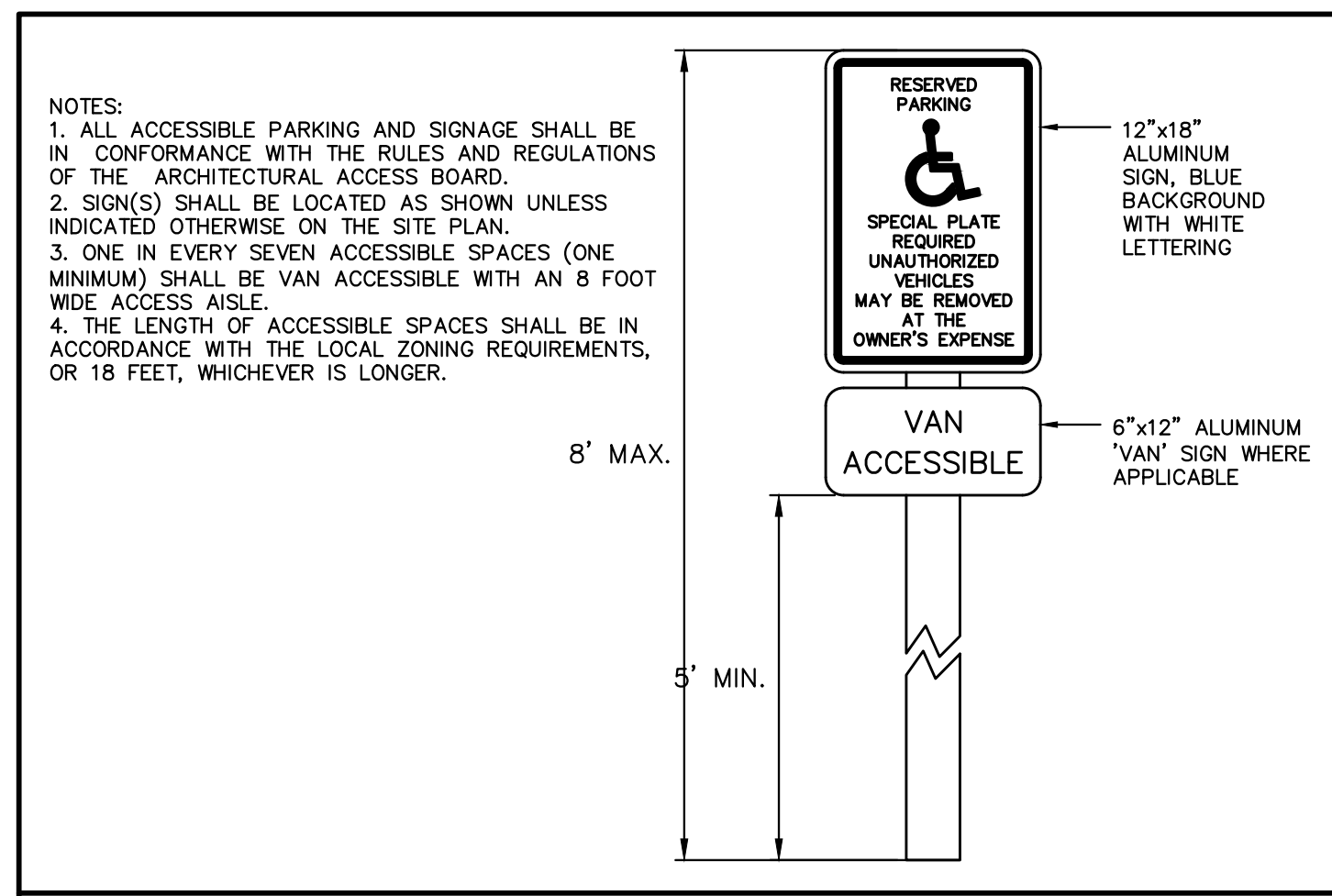
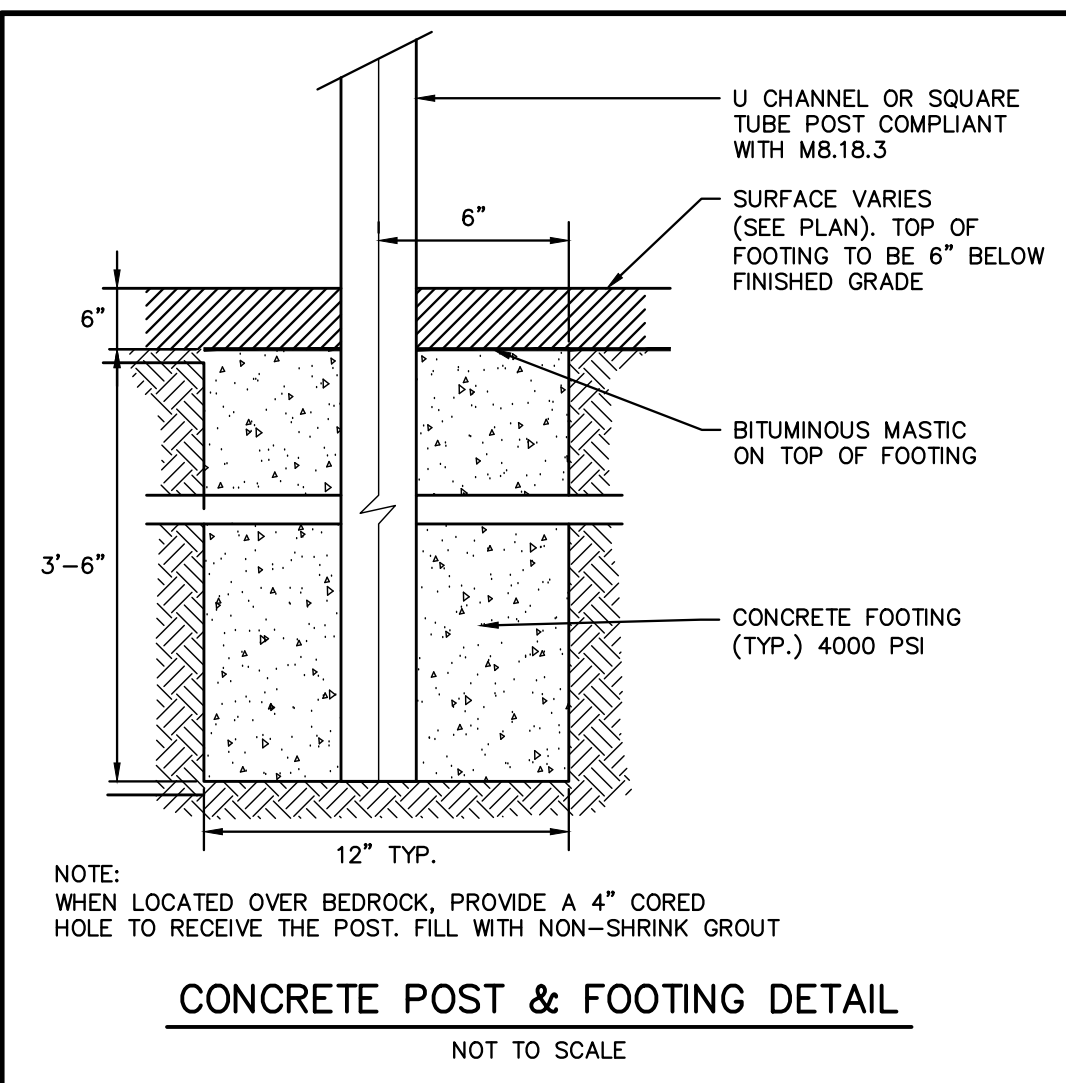
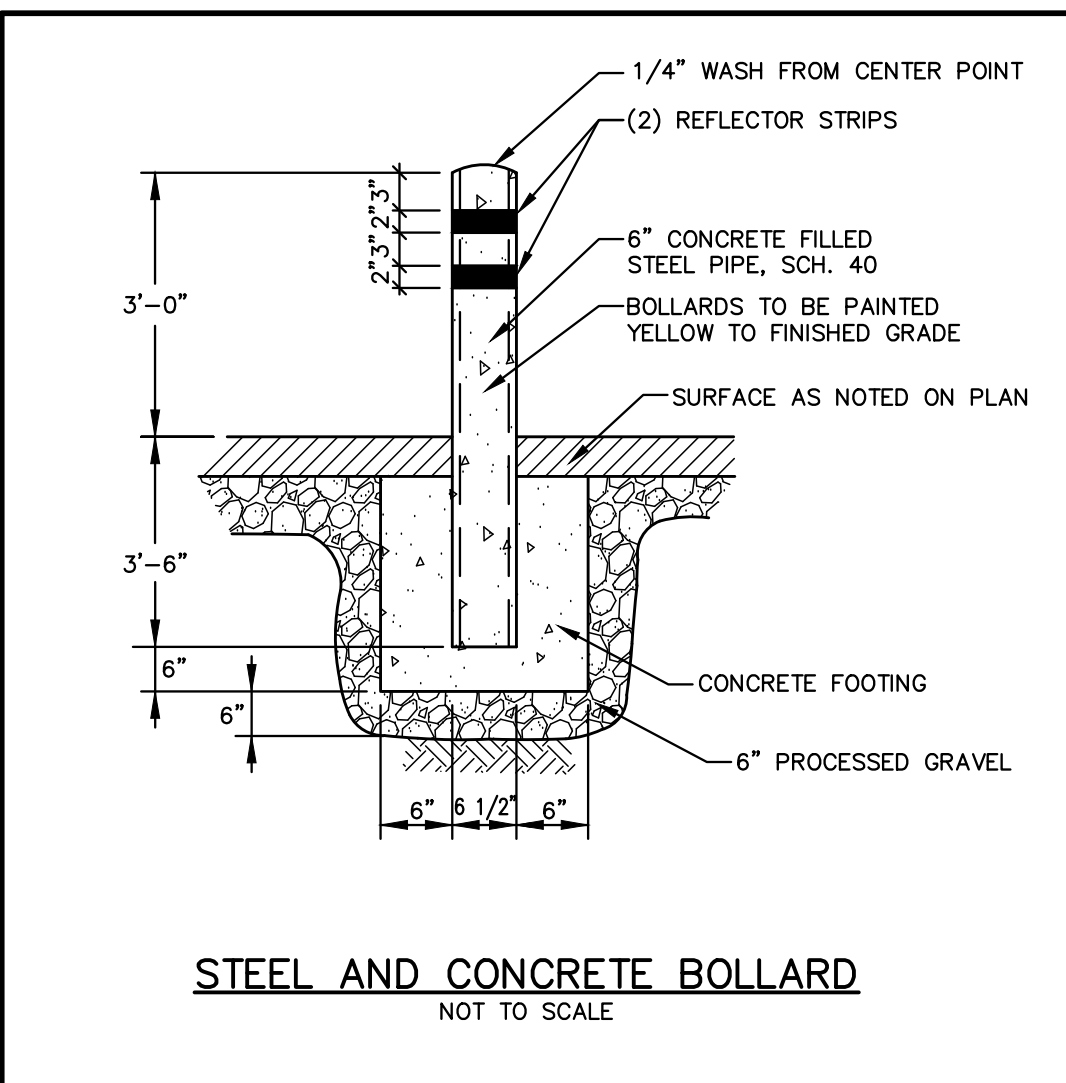
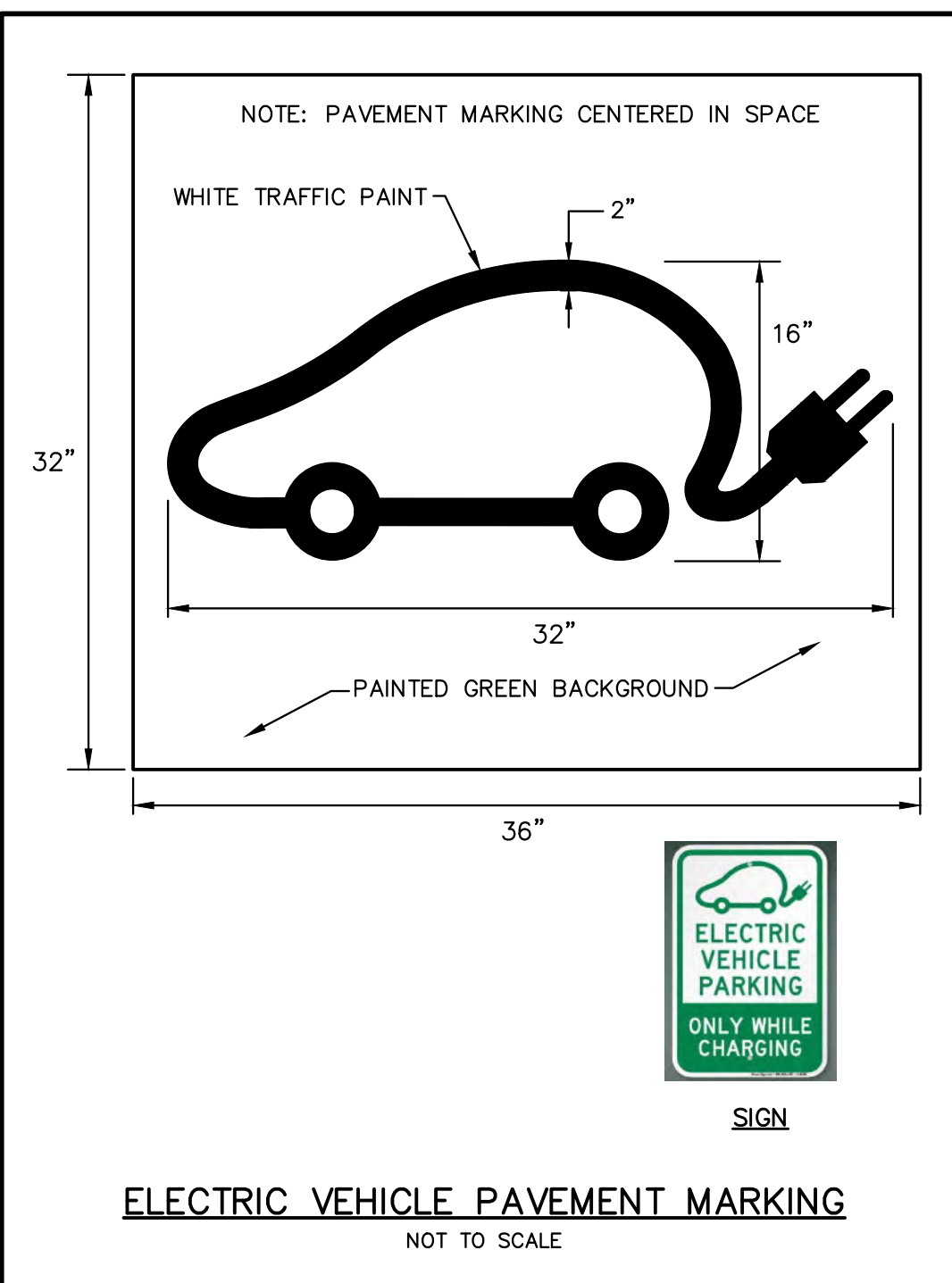

**HARBOR VUE**  
HYANNIS, MA  
WinnDevelopment Company, LP

ARCHITECT  
**ICON ARCHITECTURE**  
101 SUMMER ST BOSTON MA 02110

CONSULTANT  
**BEALS AND THOMAS**  
BEALS AND THOMAS, INC.  
144 Turnpike Road, Suite 210  
Southborough, Massachusetts 01772-2104  
T 508.366.0560 | www.bealsandthomas.com

STAMP  
JEFFREY A. HEIDELBERG CIVIL No. 48084 PROFESSIONAL ENGINEER  
REGINA E. ANDREWS REGISTERED LANDSCAPE ARCHITECT NO. 1598  
7/31/23  
Regina Andrews 7/31/2023

KEY PLAN  
**FOR PERMITTING ONLY**

1	7/31/23	SITE PLAN REVIEW
MARK	DATE	DESCRIPTION

PROJECT NUMBER: 3447.00  
DRAWN BY:  
CHECKED BY:

SHEET TITLE

**SITE DETAILS**

SCALE: AS NOTED

**C8.3**

FOR NOTES, REFERENCES AND LEGEND SEE SHEET C1.0.  
BEALS AND THOMAS, INC. SHALL NOT BE RESPONSIBLE FOR CONSTRUCTION MEANS, METHODS, TECHNIQUES, OR PROCEDURES UTILIZED BY THE CONTRACTOR, NOR FOR THE SAFETY OF PUBLIC OR CONTRACTOR'S EMPLOYEES; OR FOR THE FAILURE OF THE CONTRACTOR TO CARRY OUT THE WORK IN ACCORDANCE WITH THE CONTRACT DOCUMENTS.  
NO PART OF THIS DOCUMENT MAY BE REPRODUCED, STORED IN A RETRIEVAL SYSTEM, OR TRANSMITTED IN ANY FORM OR BY ANY MEANS, ELECTRONIC, MECHANICAL, PHOTOCOPYING, RECORDING OR OTHERWISE WITHOUT THE PRIOR WRITTEN PERMISSION OF BEALS AND THOMAS, INC. EXCEPT THAT ANY REGULATORY AUTHORITY MAY REPRODUCE AND TRANSMIT COPIES AS REQUIRED IN CONJUNCTION WITH PERFORMANCE OF OFFICIAL BUSINESS UNDER ITS JURISDICTION. ANY MODIFICATIONS TO THIS DOCUMENT WITHOUT THE WRITTEN PERMISSION OF BEALS AND THOMAS, INC. SHALL RENDER IT INVALID AND UNUSABLE.

# HARBOR VUE

HYANNIS, MA

WINN DEVELOPMENT  
COMPANY

ARCHITECT

**E-ICON**  
ARCHITECTURE  
101 SUMMER ST BOSTON MA 02110

CONSULTANT

STAMP

KEY PLAN

MARK	DATE	DESCRIPTION
PROJECT NUMBER: 223024		
DRAWN BY: Author		
CHECKED BY: Checker		

PROJECT NUMBER: 223024

DRAWN BY: Author

CHECKED BY: Checker

SHEET TITLE

CONTEXT PLAN

A-001

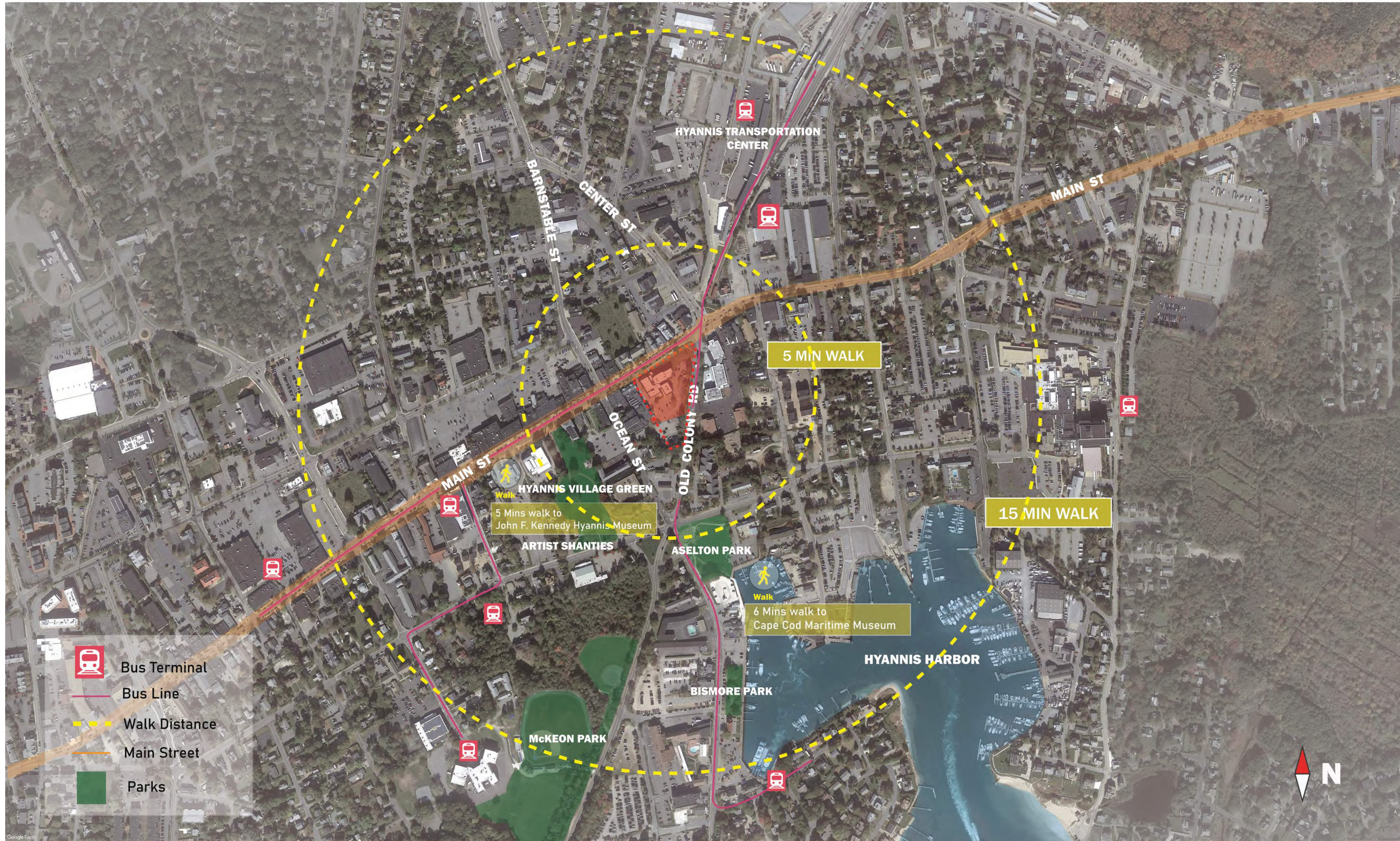

-  Bus Terminal
-  Bus Line
-  Walk Distance
-  Main Street
-  Parks

## **Exhibit 3.**

### **Evidence of Site Control**

**STANDARD FORM COMMERCIAL  
PURCHASE AND SALE AGREEMENT**  
(hereinafter referred to as the "Agreement")

This 15th day of June 2023

1. **PARTIES AND MAILING ADDRESSES** **CONRAD WATSON, AS TRUSTEE OF 307 MAIN STREET NOMINEE TRUST**, whose address is 42C Warehouse Road, Hyannis, MA 02601 (hereinafter referred to as the "SELLER") agree to sell and **WINNDEVELOPMENT COMPANY LIMITED PARTNERSHIP**, a Massachusetts limited partnership, whose address is One Washington Mall, Suite 500, Boston, Massachusetts 02108, (hereinafter referred to as the "BUYER") (SELLER and BUYER sometimes hereinafter collectively referred to as the "Parties"), agrees to buy, upon the terms hereinafter set forth, the following described premises:
2. **DESCRIPTION** The land together with the buildings thereon known and numbered **307 Main Street, Hyannis (Barnstable), Barnstable County, Massachusetts 02601** which premises is more particularly described in a deed recorded with the Barnstable County Registry of Deeds in Book 34378, Page 277 and filed with the Barnstable Land Court Registry as Document No. 1436770.
3. **BUILDINGS, STRUCTURES, IMPROVMENTS, FIXTURES** Included in the sale as a part of said premises are the buildings, structures, and improvements now thereon and the fixtures belonging to the SELLER and used in connection therewith.
4. **TITLE DEED** Said Premises are to be conveyed by a good and sufficient quitclaim deed running to the BUYER, or to the nominee designated by the BUYER by written notice to the SELLER at least seven (7) days before the deed is to be delivered as herein provided, and said deed shall convey a good and clear record and marketable title thereto, free from encumbrances, except
  - (a) Provisions of existing building and zoning laws;
  - (b) Existing rights and obligations in party walls which are not the subject of written agreement;
  - (c) Such taxes for the then current year as are not due and payable on the date of the delivery of such deed;
  - (d) Any liens for municipal betterments assessed after the date of this Agreement;
  - (e) Easements, restrictions, and reservations of record, if any, as of the date of this Agreement (and Seller shall not record any new easements, restrictions, and reservations prior to closing except with the assent of Buyer), and so long as the same do not prohibit or materially interfere with the current use of said Premises;

Prior to the expiration of the Due Diligence Period, Purchaser (i) shall order a title commitment or preliminary title report of the Property (the "**Title Commitment**"), and (ii) may, at its discretion, obtain an ALTA/ACSM as-built survey or other survey of the Property (the "**Survey**" and, together with the Title Commitment, the "**Title/Survey Materials**"). Purchaser shall provide Seller with a copy of the Title/Survey Materials.

In the event Purchaser objects to any matters shown in the Title/Survey Materials, Purchaser shall notify Seller in writing of the nature thereof ("**Title Objection Notice**") on or before the expiration of the Due Diligence Period. Seller shall then have ten (10) business days from the receipt of such notice to notify Purchaser in writing (the "**Title Objection Response Notice**") whether or not Seller is willing to cure any or all of the matters or defects set forth in the Title Objection Notice. With respect to title or survey matters first appearing on an updated Title Commitment or Survey issued after the earlier of the expiration of the Due Diligence Period or the date of the Title Objection Notice, if any, delivered by Purchaser to Seller, then upon Purchaser's discovery of same, Purchaser may send a supplemental Title Objection Notice (any such notice, a "**Supplemental Title Objection Notice**"), setting forth Purchaser's objection to such matters. Seller shall have ten (10) business days after receipt of a Supplemental Title Objection Notice to notify Purchaser in writing (the "**Supplemental Title Objection Response Notice**") of which matters Seller is willing to cure on or before the Closing.

If Seller indicates its intention in a Title Objection Response Notice or a Supplemental Title Objection Response Notice, as applicable, not to cure one or more matters identified in the Title Objection Notice or a Supplemental Title Objection Notice, as applicable, or if Purchaser does not receive a Title Objection Response Notice or Supplemental Title Objection Response Notice from Seller within ten (10) business days of the delivery to Seller of the Title Objection Notice or a Supplemental Title Objection Response Notice, as applicable, Purchaser shall have the option, within ten (10) business days of receipt of the



Title Objection Response Notice or Supplemental Title Objection Response Notice (or upon expiration of the applicable ten (10) business day period if Seller fails to timely deliver such notice), to either (i) terminate this Agreement by providing written notice of termination to Seller, whereupon the Deposit shall be returned to Purchaser, and this Agreement shall terminate and become null and void and the parties shall be released and discharged from all claims and obligations each to the other hereunder except as otherwise specifically provided in this Agreement; or (ii) accept title to the Property as Seller is required to convey in accordance with the terms of this Agreement, provided however that Seller shall remove prior to the Closing those title objection matters which Seller has agreed to cure as well as those matters Seller is obligated to cure as provided in the following paragraph.

Notwithstanding anything to the contrary herein, Seller is expressly obligated to remove prior to or as part of the Closing (a) all liens or other encumbrances against the Property caused by Seller or their affiliates or agents as well as all monetary liens such as, without limitation, any lien securing debt as well as any judgment, mechanics lien or other non-voluntary monetary lien encumbering the Property (the "Mandatory Cure Liens"), and (b) any matters Seller agreed to cure in the Title Objection Response Notice or a Supplemental Title Objection Response Notice. Purchaser shall have no obligation to object to Mandatory Cure Liens and the same shall not be deemed Permitted Encumbrances. Seller, at its option, shall be permitted to use any portion of the Purchase Price to remove any Mandatory Cure Liens and/or matters described in (b) above at the time of Closing provided that a title company acceptable to Purchaser is willing to issue owner's and lender's title insurance policies on the Closing without any exceptions therefore. If Seller fails to comply with the foregoing obligations, Purchaser shall have the right to cure the same and any amount required to be expended shall be credited against the Purchase Price payable at Closing, and in such case Purchaser shall have the right to extend the Closing as may be reasonably necessary to complete the Closing.

"Permitted Encumbrances" means all matters appearing on the Title/Survey Materials or any updated Title/Survey Materials which were (i) not included in Purchaser's Title Objection Notice or a Supplemental Title Objection Notice; or (ii) included in Purchaser's Title Objection Notice or a Supplemental Title Objection Notice but with respect to which Seller has not agreed to cure in the Title Objection Response Notice or a Supplemental Title Objection Response Notice, as applicable, except for Mandatory Cure Liens, which shall in no event be deemed to be Permitted Encumbrances.

Buyer acknowledges that the Seller has disclosed the presence of a "25' Right of Way" crossing the westerly border of the Premises, which Right of Way is shown on the draft ALTA/NSPS Land Title Survey dated October 5, 2022, prepared by Baxter Nye Engineering & Survey. It is expressly agreed that the existence of such Right of Way shall not be a basis of any Buyer Title Objection under the provisions of this paragraph and agreement. Buyer agrees to accept the Premises subject to the Right of Way and such Right of Way shall be a Permitted Encumbrance.

Buyer acknowledges that the Seller has disclosed that the Premises consists of both registered and unregistered parcels. The status of the Premises as both registered and unregistered parcels shall not be a basis of any Buyer Title Objection under the provisions of this paragraph and agreement. Buyer shall have the right to pursue a withdrawal of the Premises from the registered land system in accordance with the provisions of Section 6 of Rider A to this Agreement, but acknowledges that this is not a condition to closing.

5. PLANS                                      If said deed refers to a plan necessary to be recorded therewith the SELLER shall deliver such plan with the deed in form adequate for recording or registration.
  
6. REGISTERED TITLE                      In addition to the foregoing, if the title to said Premises is registered, said deed shall be in form sufficient to entitle the BUYER to a Certificate of Title to said Premises.
  
7. PURCHASE PRICE                        The agreed to purchase price for said Premises is **FIVE MILLION ONE HUNDRED THOUSAND AND 00/100 (\$5,100,000.00) DOLLARS**, of which  
\$ 150,000.00 have been paid as a deposit this day and  
\$ 4,950,000.00 are to be paid at the time of the delivery of the deed by wire, or by cashier's check  
\$ **5,100,000.00 TOTAL**

8. **TIME FOR PERFORMANCE; DELIVERY OF DEED ("CLOSING")** Such deed is to be delivered within **30 calendar days from "final" Site Plan Approval but in no event beyond 1 p.m. on or before December 31, 2023**, at the office of BUYER'S counsel, unless otherwise agreed upon in writing (sometimes hereinafter referred to as the "Closing" as the same may be extended pursuant to the terms of this Agreement). Site Plan Approval shall be deemed to be "final" upon expiration of all appeal periods with an appeal having been taken. Buyer agrees to close no later than December 31, 2023, regardless of the status of Site Plan Approval or expiration of any appeals thereof. **It is agreed that time is of the essence of this Agreement.**
9. **POSSESSION AND CONDITION OF PREMISES** Full possession of said Premises free of all tenants and occupants, is to be delivered at the time of the delivery of the deed, said premises to be then (a) in the same condition as they now are, reasonable use and wear thereof excepted, and (b) not in violation of said building and zoning laws, and (c) in compliance with provisions of any instrument referred to in Paragraph Four (4) hereof.
10. **EXTENSION TO PERFECT TITLE OR MAKE PREMISES CONFORM** If the SELLER shall be unable to give title or to make conveyance, or to deliver possession of the Premises, all as herein stipulated, or if at the time of the delivery of the deed the Premises does not conform with the provisions hereof, the SELLER shall use reasonable efforts to remove any defects in title, or to deliver possession as provided herein, or to make the said Premises conform to the provisions hereof, as the case may be, and the Closing shall be extended for a period of up to thirty (30) calendar days. Reasonable efforts shall not require SELLER to expend more than one half of one percent of the sales prices herein, inclusive of attorney's fees but exclusive of liens originated or assumed by SELLER or other Mandatory Cure Liens, all of which shall be satisfied at Closing by SELLER.
11. **FAILURE TO PERFECT TITLE OR MAKE PREMISES CONFORM, etc.** If at the expiration of the extended time the SELLER shall have failed to remove any defects in title, deliver possession, or make the Premises conform, as the case may be, all as herein agreed, or if at any time during the period of this Agreement or any extension thereof, the holder of a mortgage on said premises shall refuse to permit any insurance proceeds to be used for such purpose, then any payments made under this Agreement shall be forthwith refunded and all other obligations of the Parties hereto shall cease and this Agreement shall be void without recourse to the Parties hereto, unless the BUYER shall elect to accept title pursuant to Section 12 below or make demand for specific performance.
12. **BUYER'S ELECTION TO ACCEPT TITLE** The BUYER shall have the election, at either the original or any extended time for performance, to accept such title as the SELLER can deliver to the said premises in their then condition and to pay therefore the purchase price without deduction, in which case the SELLER shall convey such title, except that in the event of such conveyance in accord with the provisions of this clause, if the said premises shall have been damaged by fire or casualty insured against, the SELLER shall, unless the SELLER has previously restored the premises to their former condition, either:  
(a) pay over or assign to the BUYER, on delivery of the deed, all amounts recovered or recoverable on account of such insurance, less any amounts reasonably expended by the SELLER for any partial restorations, or  
(b) if a holder of a mortgage on said premises shall not permit the insurance proceeds or a part thereof to be used to restore the said premises to their former condition or to be so paid over or assigned, give to the BUYER a credit against the purchase price, on delivery of the deed, equal to said amounts so received or recoverable and retained by the holder of the said mortgage less any amounts reasonably expended by the SELLER for any partial restoration.
13. **ACCEPTANCE OF DEED** The acceptance and recording of a deed by the BUYER or his nominee as the case may be, shall be deemed to be a full performance and discharge of every agreement and obligation herein contained or expressed, except such as are, by the terms hereof, to be performed after the delivery of said deed.
14. **USE OF MONEY TO CLEAR TITLE** To enable the SELLER to make conveyance as herein provided, the SELLER may, at the time of delivery of the deed, use the purchase money or any portion thereof to clear the title of any or all encumbrances or interests, provided that all instruments so procured are recorded within a reasonable time after the delivery of said deed in accordance with local conveyancing practices.
15. **INSURANCE** SELLER does not presently maintain any insurance on the Premises and shall not be obligated to insure the premises during the pendency of this Agreement.
16. **ADJUSTMENTS** Water and Sewer shall be adjusted at the time of closing. Taxes (including BID Taxes if applicable) for the then current fiscal year in which the closing takes place and common expense for the then current month, shall be apportioned as of the day of performance of this Agreement and the net amount thereof shall be added to or deducted from, as the case may be, the purchase price payable by the BUYER at the time of delivery of the deed.

17. ADJUSTMENT OF UNASSESSED AND ABATED TAXES  
If the amount of said taxes is not known at the time of the delivery of the deed, they shall be apportioned on the basis of the taxes assessed for the preceding fiscal year, with a reapportionment as soon as the new tax rate and valuation can be ascertained; and, if the taxes which are to be apportioned shall thereafter be reduced by abatement, the amount of such abatement, less the reasonable cost of obtaining the same, shall be apportioned between the Parties, provided that neither party shall be obligated to institute or prosecute proceedings for an abatement unless herein otherwise agreed.
18. BROKER'S FEE  
Tom Foley is the only broker involved in the transaction. Seller shall pay Tom Foley a brokerage fee at Closing pursuant to a separate agreement only if a Closing occurs. Seller and BUYER shall each indemnify and hold the other harmless from any claims relating to any broker other than Tom Foley.
19. BROKER(S) WARRANTY  
The Broker named herein represent and warrants that he is duly licensed in the Commonwealth of Massachusetts.
20. DEPOSIT  
All deposits made hereunder shall be held in escrow by Lepizzera Laprocina Title & Escrow, LLC as escrow agent subject to the terms of this Agreement and shall be duly accounted for at the time for performance of this Agreement. In the event of any disagreement between the Parties, the escrow agent shall retain all deposits made under this Agreement pending instructions mutually given by the SELLER and the BUYER or the final judgment of a court with competent jurisdiction. The delivery, acceptance and recording of the Deed shall in all cases constitute the Parties' joint authorization for the release of all deposits held hereunder. Interest, if any, shall be divided equally between BUYER and SELLERS at closing except if no closing takes place then interest shall follow the deposit. The deposit shall be held in a non-interest bearing account.
21. DEFAULT; DAMAGES  
If the BUYER shall fail to fulfill the BUYER'S agreements herein, all deposits made hereunder by the BUYER shall be retained by the SELLER as liquidated damages and this shall be SELLER'S sole and exclusive remedy at both law and in equity.  
  
If the SELLER shall fail to fulfill the SELLER'S agreements herein, BUYER shall have the right to seek to enforce all available remedies at law, in equity or otherwise, including without limitation the right to seek specific performance and to recover any actual or consequential damages, which shall be capped in the maximum amount of up to \$300,000 unless the SELLER shall willfully and intentionally default.
22. LIABILITY OF TRUSTEE, SHAREHOLDER, BENEFICIARY, etc.  
If the SELLER or BUYER executes this Agreement in a representative or fiduciary capacity, only the principal or the estate represented shall be bound, and neither the SELLER or BUYER so executing, nor any shareholder or beneficiary of any trust, shall be personally liable for any obligation, express or implied, hereunder, except to the extent of the beneficiary's interest in the Premises in the case of a nominee trust.
23. WARRANTIES AND REPRESENTATIONS  
The BUYER acknowledges that the BUYER has not been influenced to enter into this transaction nor have they relied upon any warranties or representations not set forth or incorporated in this Agreement, except for the following additional warranties and representations, if any, made by either the SELLER or the SELLER's agent(s):  
  
NONE BY SELLER, EXCEPT AS EXPRESSLY SET FORTH IN THIS AGREEMENT OR RIDER
24. FINANCING CONTINGENCY CLAUSE  
INTENTIONALLY DELETED
25. ACCESS  
The SELLER shall make the premises available upon reasonable advance notice for inspection and measurement at any time prior to delivery of the deed by representatives and designees (including surveyors, architects, engineers and appraisers) of the BUYER in order to facilitate the BUYER'S purchase of the premises.

26. CONSTRUCTION OF AGREEMENT

This Agreement, executed in multiple counterparts, is to be construed as a Massachusetts contract, is to take effect as a sealed instrument, sets forth the entire contract between the Parties, is binding upon and ensures to the benefit of the Parties hereto and their respective heirs, devisees, executors, administrators, successors and assigns, and may be canceled, modified or amended only by a written instrument executed by both the SELLER and the BUYER or their respective attorneys. The Parties may rely upon facsimile copies of such written instruments. If two or more persons are named herein as BUYER and/or SELLER, their respective obligations hereunder shall be joint and several. The captions and marginal notes are used only as a matter of convenience and are not to be considered a part of this Agreement or to be used in determining the intent of the Parties to it.

33. ADDITIONAL PROVISIONS

Rider A is attached hereto and incorporated by reference herein.

BUYER shall keep SELLER informed of BUYER's progress in preparing plans, layouts of buildings, elevations, designs and engineering, and obtaining any permits and approvals, including providing copies of all such plans, and applications for permits filed with the Town of Barnstable and advising SELLER of all hearing or review dates scheduled.

**NOTICE: THIS IS A LEGAL DOCUMENT THAT CREATES BINDING OBLIGATIONS. IF NOT UNDERSTOOD, CONSULT AN ATTORNEY.**

SELLER:

307 Main Street Nominee Trust:

  
By: Conrad Watson, Trustee

BUYER:

WinnDevelopment Company Limited Partnership:

  
By: WDP Manager Corp., its General Partner  
By: Lawrence H. Curtis,



Or to such other address or addresses as may from time to time be designated by either party by written notice to the other. By executing this Agreement, the BUYER and SELLER hereby grant to their attorneys the actual authority to bind them for the sole limited purpose of allowing them to cancel, grant extensions, modify or amend this Agreement in writing, and the BUYER and SELLER shall be able to rely upon the signatures of said attorneys as binding unless they have actual knowledge that the principals have disclaimed the authority granted herein to bind them. Further, for purposes of this Agreement, email transmissions and/or facsimile signatures on such written instruments shall be binding, provided however that no party shall avoid any obligation hereunder by failing to provide such original signature.

4. **1031 Cooperation** – The parties acknowledge that the SELLER may desire to sell the Property and acquire a replacement property in accordance with Section 1031 of the Internal Revenue Code of 1986, as amended. At the request of SELLER, BUYER will cooperate with SELLER's efforts in effectuating the Section 1031 exchange. SELLER may assign its interests in this Agreement to effectuate a tax-free exchange as aforesaid, and in such event, SELLER shall promptly so notify BUYER, provided, no such assignment shall affect in any way the obligations of SELLER under this Agreement. BUYER shall not be required to incur any liabilities in connection with such exchange by SELLER nor shall BUYER be required to take title to any other property in connection with such exchange. SELLER shall pay any additional transfer taxes, recording fees and similar closing costs incurred by BUYER resulting from such tax-free exchange.
5. **Cooperation** - In connection with the Approvals, Seller agrees to sign any applications or authorizations, promptly upon request, which are required to be signed by the owner of the Property and authorizes BUYER to sign such applications on behalf of Seller if necessary to expedite the filing of an application. Seller further agrees that if, at BUYER's election, BUYER desires Seller's assistance in pursuing any Approvals, then Seller agrees to assist and work in cooperation with BUYER in the pursuit of such Approvals from any and all governmental agencies having jurisdiction; it being understood, however, that BUYER shall be solely responsible for BUYER's cost in pursuing Approvals including without limitation engineering, surveys, approval fees and permits, and professional/expert studies, and Seller's cooperation will not obligate Seller to incur any third party costs in connection with seeking such Approvals.
6. **Withdrawal from Registered Land** - The Property consists of multiple parcels of both registered and unregistered land. Buyer, at its sole cost and expense, shall have the right (but not the obligation) prior to closing to file a petition and pursue an action, in the name of Seller (as owner of the Premises), to deregister and withdraw the Premises from the Land Court Registration System, and to take all actions and make all associated filings and assents, as necessary, in furtherance thereof, in order to withdraw all portions of the Property which are registered from the land registration system. Seller shall cooperate in good faith with Buyer, and shall execute or cause to be executed all documents, instruments and authorizations necessary or as reasonably requested by Buyer to pursue and complete such withdrawal of the registered land. The Buyer's obligation to close is not subject to completing the withdrawal of the Property from the registered land system, and Buyer agrees to close at the time required by this Agreement whether or not the withdrawal and deregistration of the land has then been completed.
7. **Miscellaneous** - This Agreement shall be binding upon and inure to the benefit of the successors and assigns of the parties. Headings are for convenience of reference only and have no independent legal significance. This Agreement may not be modified, waived or amended except in a writing signed by the parties hereto. Any and all prior and contemporaneous discussions, undertakings, agreements and understandings of the parties are merged in this Agreement, and the exhibits referenced herein, which alone fully and completely express their entire agreement. It is expressly understood and agreed that time is of the essence with respect to this Agreement. If any term or provision of this Agreement or the application thereof to any person or circumstances shall, at any time or to any extent, be invalid or unenforceable, the remainder of this Agreement, or the application of such term or provision to persons or circumstances other than those as to which this Agreement is held invalid or unenforceable, shall not be affected thereby, and each term and provision of this Agreement shall be valid and be enforced to the fullest extent permitted by law. This Agreement shall be governed by and construed and enforced in accordance with the laws in effect in the Commonwealth of Massachusetts.
8. **Confidentiality** - Seller and BUYER shall each keep strictly confidential the terms of this Agreement, any negotiations pertaining to the transactions contemplated hereby and any information that either party furnishes to the other pursuant hereto. Unless compelled by legal process, each party shall maintain the confidentiality of such information and shall not disclose same to persons other than its employees, agents, affiliates, attorneys, accountants, lenders and consultants. Notwithstanding the provisions of this Section, BUYER may make any disclosures as necessary concerning the proposed purchase as shall be reasonably required to complete its Due Diligence Investigations or in connection with seeking Site Plan Review or determining the feasibility of obtaining Site Plan Review, including without limitation engaging in discussions with or submitting information and applications to federal, state or local officials, governmental agencies or employees.
9. **Exclusivity** – Seller shall cease discussions regarding the Property with other prospective purchasers, and Seller shall not furnish information regarding the Property to other prospective purchasers. Seller shall neither solicit nor accept any offers, whether or not binding, regarding the Property through Closing, unless this Agreement is terminated.
10. **Seller' Covenants Regarding Operating of the Property Prior to Closing** - Seller, at Seller' expense, shall maintain the Property in its present condition, subject to normal wear and tear. Until Closing, Seller, at Seller's expense, shall operate the

Property in substantially the same manner as the Property is being operated on the date of this Agreement, but shall not enter into any contracts or agreements, except with BUYER's written consent.

Seller acknowledges that there are no existing tenants currently leasing a portion of the Property (the "Tenants"). Notwithstanding the foregoing, prior to Closing, Seller shall remove or relocate any and all Tenants or occupants from the Property. Seller represents and agrees not to enter into any modification of an existing lease or any new lease of any portion of the Property prior to Closing which grants any Tenant any rights which could survive Closing or otherwise affect BUYER. Seller shall be responsible for the relocation (and any costs associated thereof) of any Tenants. If Seller is unable to remove all Tenants from the Property prior to Closing, Seller shall forfeit to BUYER its rights to all Deposit(s) and BUYER will have the right in its sole discretion to terminate this Agreement with no obligation to Seller.

11. **"As Is Status"** – Subject to BUYER's Due Diligence Review and following the conclusion of the Due Diligence Review Period, BUYER warrants, represents and acknowledges to SELLER and agrees that SELLER is relying upon the following: BUYER acknowledges they have been provided ample opportunity to conduct any and all inspections of the premises (either independently or through agents of the BUYER's choice), including all improvements thereon, and any and all component parts thereof, and that the SELLER has no responsibility for any failure by the BUYER to fully exercise such inspection rights. BUYER's opportunity included without limitation, the mechanical, structural, groundwater tables, utility systems, all appliances and personal property being conveyed with the premises, pest, termite, lead paint, asbestos, radon, mold, and any hazardous chemicals, materials or substances, dimensions and area of the premises, and flood policy information and pricing if/as necessary, and that BUYER is fully satisfied with the results of same. BUYER further represents and agrees that the existence of any matter or condition revealed by, or which could have been revealed by, such inspections, shall not be deemed to be a default by SELLER under this Agreement. Without intending to limit the generality of the foregoing, SELLER does not warrant or represent that the premises complies with current municipal, county, state or federal codes, ordinances, statutes, laws, regulations or the like, relating to zoning, building, environmental, health or any involving the maintenance, operation or condition of the premises. The BUYER is purchasing the premises to be conveyed pursuant to this Agreement in its **"AS IS, WHERE IS, WITH ALL FAULTS"** condition as of the date hereof subject to the SELLER's obligation to maintain the premises as required in Paragraph 10 above. The provisions of this paragraph shall survive the delivery and recording of the Deed.
12. **REBA Standards** - Any title or practice matter arising under or relating to this Agreement which is the subject of a title or practice standard of the Real Estate Bar Association ("REBA") shall be governed by said title or practice standard to the extent applicable and to the extent such title or practice standard does not contradict any expressed term or condition of this Agreement.
13. **Full Agreement** - SELLER shall not be liable or bound in any way for any verbal or written statements, representations, or information pertaining to the premises furnished by any real estate broker or agent or any agent or employee of SELLER, or any other person. It is understood and agreed that all prior and contemporaneous representations, statements, understandings and agreements, oral or written, between the parties are merged in this Agreement, which alone fully and completely expresses their agreement, and that the same is entered into after full investigation, neither party relying on any statement or representation not embodied in this Agreement made by the other. All offers, agreements, and any other understanding made prior to this Agreement, including without limitation, the memorandum executed by the Parties hereto, entitled "Contract to Purchase Real Estate" ("Offer"), are hereby superseded, rendered null and void and shall have no further force and effect, it being the intent of the Parties that all obligations of the Parties are contained only in this Agreement and this Agreement represents the complete and full agreement of the parties hereto.
14. **Full Performance** - The acceptance and recording of the deed by BUYER on the Closing Date shall be deemed full performance and discharge of each and every agreement and obligation on the part of the SELLER hereunder to be performed. Any and all representations and warranties of SELLER contained in this Agreement shall not survive the Closing Date except as otherwise agreed herein.
15. **SELLER Documents** - SELLER shall deliver at closing such documents and certificates as shall be reasonably requested by the BUYER's lender or closing agent or BUYER's title insurer, including but not limited to an affidavit to establish exemption under Internal Revenue Code 1445(B)(2), title insurance affidavit regarding the absence of parties-in-possession and mechanics' liens, a so-called trustee's certificate and original smoke and carbon monoxide certificate.
16. **Invalid Terms** - If this Agreement or any other provision by way of reference incorporated herein shall contain any term or provision which shall be invalid, then the remainder of the Agreement or other instrument by way of reference incorporated herein, as the case may be, shall not be affected thereby and shall remain valid and in full force and effect to the fullest extent permitted by law.
17. **SELLER's Actual Knowledge** - All of SELLER's representations under this Agreement are to the SELLER's actual knowledge, and without conducting any independent investigation or inquiry and are not intended to imply or create any obligation for the SELLER to take additional actions or more further inquiry with regard to any topics contained within this Agreement or elsewhere, including but not limited to, documents, to be executed in conjunction with the Closing; furthermore, it is acknowledged and agreed by the Parties that any such representations shall not constitute a representation or warranty against the existence of such conditions about which SELLER has no knowledge, nor a representation or warranty against the discovery or occurrence of such conditions. Subject to the foregoing, the SELLER represents and warrants to the matters as set forth in the attached **Exhibit A**. The provisions of this paragraph shall survive the Closing and the delivery of the Deed hereunder.

18. Weekends/Holidays - In the event that any deadline or date for performance or providing notice contained herein (including, without limitation, any contingencies or extensions of the time for performance under this Agreement), falls on a Saturday, Sunday or legal holiday, as the case may be, such deadline or other date shall be automatically extended to the immediately following business day.
19. Opportunity for Counsel - Both BUYER and SELLER hereby acknowledge that they have been offered the opportunity to seek and confer with qualified legal counsel of their choice prior to signing this Agreement.

SELLER:

307 Main Street Nominee Trust:

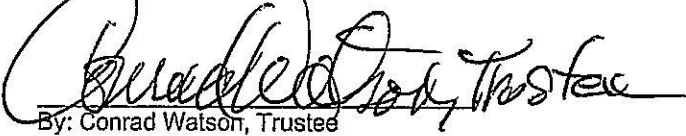

By: Conrad Watson, Trustee

BUYER:

WinnDevelopment Company Limited Partnership:

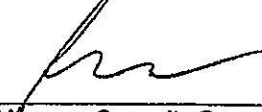

By: WDP Manager Corp., its General Partner  
By: Lawrence H. Curtis, duly authorized



## Exhibit A

### Seller Representations and Warranties

Seller represents and warrants as follows, subject to the limitations set forth in Section 19 of Rider A:

- (a) Seller has the power and authority to sell, transfer, convey and deliver the Premises to be sold and purchased hereunder and all required action and approvals therefor have been duly taken and obtained. The entities and individuals signing this Agreement and all other documents executed pursuant hereto on behalf of Seller has been duly authorized to sign same on behalf of Seller and to bind Seller.
- (b) The execution and delivery of this Agreement, the consummation of the transactions provided for herein and the fulfillment of the terms hereof will not result in a breach of any of the terms or provisions of, or constitute a default under, any agreement of Seller or any instrument to which Seller is a party or by which Seller or the Property is bound, or any judgment, decree or order of any court or governmental body, or any applicable law, rule or regulation.
- (c) At Closing, Seller will have and will convey and transfer to Buyer, or its nominee, good, indefeasible and marketable title to the Property, free and clear of all mortgages, liens, encumbrances, ground rents, leases, tenancies, licenses, security interests, covenants, conditions, restrictions, rights of way, easements, encroachments and any other matters affecting title, subject only to the matters referenced in Section 4 of the main body of the Agreement.
- (d) There are no leases or tenancies for or any other right to occupy all or any portion of the Premises, and there are no outstanding agreements or rights, oral or otherwise, that have been granted to any third party or which are otherwise outstanding with respect to and affecting the Premises, including without limitation any rights to use, occupy or purchase the Premises, except as have otherwise been disclosed in this Agreement. Seller shall not enter into any lease or grant any person the right to occupy all or any part of the Premises without Buyer's prior, written approval in each instance, which approval may be withheld for any reason.
- (e) No written notice has been given to Seller by any holder of any mortgage or deed of trust on the Premises or by any insurance company which has issued a policy with respect to any of the Premises of any defect or deficiency, nor has any such party requested the performance of any repairs, alterations or other work to the Premises. If such notice is received by Seller prior to Closing, Seller shall promptly inform Purchaser of the notice. Seller will not complete repairs, alterations or other work required in order to comply with such notice and to correct any such defect prior to Closing unless requested to do so by Purchaser, in which event such work shall be completed at Seller's sole cost and expense.
- (f) There is no pending condemnation, eminent domain, or similar proceeding affecting all or any portion of Premises, and Seller has not received any written notice of any of the same and Seller has no knowledge that any such proceeding is contemplated.
- (g) There are no management, service, equipment, supply, maintenance, cable, internet or other or other similar agreements ("Service Contracts") with respect to or affecting all or any portion of the Premises which will remain in place after Closing, and any such agreements, if any, shall be terminated by Seller prior to Closing at Seller's cost and expense. True, correct and complete copies of all existing leases and Service Contracts, if any, affecting the Property will be delivered to Buyer upon execution of this Agreement by Seller. Seller shall not enter into any new or amend any existing commercial leases or Service Contracts prior to Closing, except to terminate any such Service Contract or Agreement as of the Closing at its sole cost
- (h) No portion of the Premises is subject to or is affected by any special assessment or special taxing district that is not disclosed on the real estate tax bills and, to Seller's knowledge, no such assessment has been proposed, excepting the Business Improvement District Taxes. Buyer will be responsible only for payments of any such assessment due on or after Closing, and Seller will be responsible for payments of any such assessment due prior to Closing.

- (i) No default or breach exists under any of the covenants, conditions, restrictions, rights-of-way, or easements, if any, affecting the Premises which are to be performed or complied with by the owner of the Premises.
- (j) As of the date hereof there is no action, suit or proceeding pending or, to the knowledge of the Seller, threatened against or affecting all or any portion of the Premises, or any commercial leases or Service Contracts, or relating to or arising out of the ownership of the Premises, in any court or before or by any federal, state, county or municipal department, commission, board, bureau, or agency or other governmental instrumentality. If any such action, suit or proceeding exists, comes to the knowledge of Seller between the date hereof and Closing, Seller shall immediately notify Buyer.
- (k) Seller has no knowledge of any fact that would prevent or materially affect access to the Premises or the availability to the Property of water, sewer, gas, electric, and all other utilities.
- (l) To the best of Seller's knowledge and belief, no Hazardous Materials (hereinafter defined) exist on or have been placed on the Premises or have been released into the environment, or discharged, placed or disposed of at, on or under the Premises (except minor quantities of substances used by Seller in compliance with applicable laws); no storage tanks have been placed on the Premises; the Premises has not been used as a dump for waste material; and the Premises complies with applicable federal, state or local governmental laws, regulations, ordinances, codes, statutes or requirements relating to the emission, discharge, release, or threatened release of Hazardous Materials into the environment, and to environmental and occupational health and safety matters and Hazardous Materials.

The term "Hazardous Materials" shall mean and include the following, including mixtures thereof; any hazardous substance, pollutant, contaminant, waste, by-product, or constituent regulated under federal, state or local law, including, without limitation, the Comprehensive Environmental Response, Compensation and Liability Act, 42 U.S.C. Section 9601 et. Seq.; oil and petroleum products and natural gas, natural gas liquids, liquefied natural gas, synthetic gas usable for fuel; pesticides, regulated under the Federal Insecticide, Fungicide, and Rodenticide Act, 7 U.S.C. Section 136 et. Seq.; asbestos and asbestos-containing materials, PCBs and other substances regulated under the Toxic Substances Control Act, 15 U.S.C. Section 2601 et. Seq.; source material, special nuclear material, by-product material and any other radioactive materials or radioactive wastes, however produced, regulated under the Atomic Energy Act or the Nuclear Waste Policy Act of 1982; chemicals subject to the OSHA Hazard Communication Standard, 29 C.F.R. 1910.1200 et. Seq.; and industrial process and pollution control wastes, whether or not hazardous within the meaning of the Resource Conservation and Recovery Act, 42 U.S.C. Section 6901 et seq.

- (m) Seller has received no notice of default, and, to the best of Seller's knowledge, there is no default, or occurrence which, with the passage of time or delivery of notice, would constitute a default under any existing debt secured by the Premises or any part of the Premises.
- (n) There are no attachments, executions, or assignments for the benefit of creditors or voluntary proceedings in bankruptcy or under any other debtor relief laws pending or threatened by or against Seller or otherwise affecting the Premises or any portion thereof.

**Exhibit 4.**

**Management Plan & Profile**

## Exhibit 4: Management Plan; Management Agent Profile

### Management Plan

As the Managing Agent for the Property, Winn Managed Properties LLC (“Winn”) will be responsible for the following tasks: rent-up and marketing, daily operations, maintenance and repairs, budgeting, accounting, and tenant relations. The Divisional VP will supervise the site’s Property Manager who will have direct responsibility for the oversight of the property, including, but not limited to:

1. hiring, training and supervision of maintenance personnel and other staff members, if any;
2. preparing and enforcing all rental procedures and reports;
3. coordinating all community and resident relations including resident organization meetings;
4. supervising all repairs, redecoration, and maintenance projects;
5. preparing all accounting, occupancy, marketing, equal opportunity and operational reports and;
6. preparing the annual budget.

All of the above functions will be performed in accordance with generally accepted professional standards, federal, state and local agency guidelines, and the Management Agreement.

### Staffing

**Property Manager.** The Property Manager will manage the day-to-day operations at the Harbor Vue Hyannis. The Property Manager will work 40 hours per week and will be fully trained in all areas of property management: housing program rules and regulations, commercial space rules and regulations, marketing, accounting, budgeting, reporting and maintenance (including preventive maintenance). The Property Manager will also supervise the maintenance superintendent.

**Maintenance.** A Superintendent will monitor the maintenance operation. The Superintendent will work 40 hours per week. The Superintendent will receive technical support from WinnResidential’s Regional Maintenance Coordinator, a senior level maintenance expert assigned to WinnResidential’s Boston Region; these services are provided at no cost to the property.

**Cleaning services** will be contracted for. The Agent will utilize one of the locally owned MBE companies it currently does business with.

Should other employees be required, the Property Manager will train and supervise them; job descriptions will be developed for each new position.

WinnResidential conforms with equal employment opportunity requirement in its hiring and promotional practices. Applicants will be interviewed, and their qualifications judged without regard to race, color, age, sex, or handicap.

Full-time personnel will be eligible for benefits such as medical insurance, vacation and sick pay. All expenses relating to employment of the Property Manager and the staff will be paid for by the property.

The Divisional Vice President will visit the site at least monthly and will be in regular contact with the site management office. WinnResidential’s senior staff will be available to the Owner on an as needed basis to discuss any issues or problems at the property.

All expenses incurred by senior supervisory management staff will be borne by WinnResidential.

### Marketing/Tenant Selection/Occupancy

The Agent will implement the Project's approved Marketing Plan. The Managing Agent will follow federal, state, and local laws prohibiting discrimination as described in the Management Agreement.

When the number of applicants for a particular bedroom size dictates that the wait list should be opened, advertisements will be placed in area and local newspapers. Marketing, the employment of commercial brokers and application screening will provide the project with qualified residents and commercial occupants. To accomplish this, the Property Manager will conduct interviews with applicants, review qualifying criteria and verify information from third party sources. The Property Manager will also explain procedures and answer questions on operational features of the units and property. Topics covered will include rent and maintenance policies, as well as planned activity programs and services. The lease and rules and regulations and the hazardous material restrictions against penetrating pavement or the top 3 feet of soil in unpaved areas will be explained in detail; if necessary, a translator will be provided.

Each resident will receive an explanatory Resident Handbook reviewing all the Property's policies for the residential units. The property manager will inspect the apartment/commercial space with the resident/commercial tenant, utilizing a checklist which both will initial. Care of the unit/commercial space, operation of appliances and emergency situations will be discussed.

The Property Manager will be trained in and follow all regulations related to leasing of LIHTC, Home/HSF and PBV units or any other regulatory requirements; the Property Manager will attend continuing professional education programs in LIHTC, HOME/HSF and PBV programs. S/he will make an initial determination of the applicant's household income based on a preliminary application and interview where applicable for any income/rent-restricted apartments.

**Inspections.** Unit inspections will be performed by the Property Manager and the tenant at initial occupancy, and at least once annually in accordance with the building inspection schedule (or more frequently if required) and prior to moveout. The Unit Inspection Form will be used to record the results of the inspection. The Property Manager and the condition described.

The Property Manager will inspect the public areas of the building on a bi-weekly basis. On an annual basis, a third-party contractor will be hired to inspect all fire and safety equipment.

#### **Eviction Procedures.**

The Housing Stability Program was created pre-pandemic (in December 2019) and launched with over 3,500 staff in March 2020. This program has received national recognition from the White House, the National Apartment Association (NAA), and the Urban Land Institute (ULI).

The goal of our plan was to reduce evictions for non-payment of rent by 50% across our nationwide portfolio by 2025 through a combination of upstream, early and consistent interventions featuring education, two-way communication, and hands-on assistance. The four key elements are:

1. Providing residents education on rights and lease responsibilities, and with our partners,

connecting them to local resources like mediation, counseling and financial coaching;

2. Working through achievable, affordable and sustainable payment agreements often as long as nine months;

3. Implementing accountable housing stability goals – rather than eviction metrics – for both the on-site property management teams, as well as the more than 100 law firms with which we work; and finally,

4. Imposing a strong focus and accountability on robust coordination and assistance in completing successful applications for Emergency Rental Assistance programs.

Since March 2020, over 50,000 households of all incomes have been supported through some element of our Housing Stability Program (about 110,000 adults and children) to avoid eviction sustainably through:

- benefits and unemployment application assistance for those who lost work and steady income;
- holistic, responsible rent payment agreements for residents returning to work and getting on their feet;
- coordinated mediation services with our legal services and community partners; and
- Owning the Emergency Rent Assistance application and submission and submission process

WinnCompanies team members have facilitated ERAP applications totaling almost \$50 million, with over \$37 million collected successfully to date through these U.S. Treasury Programs to sustain ongoing property operations while preventing evictions.

While evictions are not always avoidable, WinnCompanies is proud to have ZERO evictions for households who have participated in our Housing Stability Program. For households who do not participate in the Housing Stability Program, WinnCompanies continues its outreach efforts throughout the Notice to Quit and Eviction Summary Process filing. In these instances, evictions are only initiated for households with continued non-payment violations and other substantial violations of the lease, which are outlined as an addendum to the lease and uniformly applied.

### **Maintenance/Repairs/Preventative Maintenance**

The Property Manager and Superintendent will test and inspect the property's mechanical equipment and appliances. Improperly installed or inoperative equipment and appliances will be brought to the attention of the Client.

The Property Manager will make an inventory of mechanical equipment, appliances, spare parts and cleaning materials along with a schedule of preventive maintenance in accordance with company procedures. Normal use and care of appliances by the residents will be spelled out during resident orientation and in the Resident Handbook.

The Property Manager will schedule daily and periodic building and grounds maintenance tasks which will be performed by the Superintendent: grounds will be policed for litter; entrance areas, sidewalk, and parking areas cleaned as required; trees and shrubs fed and pruned as required; snow and ice removed from sidewalks.

**Trash.** Tenants will dispose of garbage and deposit trash in covered receptacles. If required, the Superintendent will bring the trash containers out to the street location and then return them back to the storage area. Refuse will be removed by an independent contractor and/or Hyannis.

**Move-outs.** Prior to move-out, the Property Manager will inspect the apartment / commercial space with the current tenant, listing cleaning, repairs, and painting to be performed. Turnover work will be performed immediately after the space is vacated in order to minimize vacancy loss. All damages will be noted and reported for possible charges to the former resident. In accordance with Massachusetts law, the return of the security deposit, plus appropriate interest, will be refunded net of any charges.

**Repairs.** Routine and/or minor repairs will be made by the Superintendent whenever possible. Electrical, plumbing and heating repairs, etc., which require the services of a licensed contractor, will be contracted for. Major repairs will be reviewed in advance with the Client. All work will be inspected by both the Property Manager and Superintendent. Repair and maintenance requests will be recorded on a work order form which will include the following information: the date of the request, work order number, name and apartment number of resident (or applicable commercial space and tenant), description of work, date work is scheduled, date of work completion, and signature of tenant signifying acceptance. The work orders will be entered in numerical order in a log for easy reference. Tenants will report emergencies by calling the office. An answering service will be available to receive calls outside of business hours. Maintenance requests will be handled promptly during normal working hours; emergencies will be covered on a twenty-four (24) hour basis.

**Purchases.** The Superintendent will be authorized to make purchases or to order repairs up to \$100.00 (emergencies excepted) unless such items have previously been scheduled as part of the preventive maintenance program. Purchases over \$100.00 and below \$1,500.00 require approval by the Property Manager. Purchases \$1,500.00 or over require Divisional Vice President approval. Purchase orders will be produced by the property's purchasing software module.

**Unit Inspections.** Unit and commercial space inspections will take place at least annually by the Property Manager and Superintendent. The inspection will include all mechanical equipment and systems, plumbing fixtures, and electrical fixtures, as well as damage to walls, ceilings, windows, screens and flooring. Housekeeping practices by tenants will also be noted on the inspection report. All items requiring corrective action will be completed by the manager and maintenance person.

**Emergencies.** All tenants will be instructed on the proper procedures to follow in the event of a general maintenance, fire or medical emergency. Twenty-four (24) hour emergency response will be provided. Appropriate back-up is available to support The Superintendent, during and after business hours.

**Preventive Maintenance.** A detailed preventive maintenance ("PM") schedule will be developed by WinnResidential's Regional Maintenance Coordinator. Each task on the schedule will have written instructions for reference by the Superintendent. Each month the Property Manager will write work orders for each PM task scheduled for that particular month and will monitor their completion.

### **Accounting/Reporting**

Computerized accounting services will be performed in the Managing Agent's central office in Boston. Within fifteen (15) working days, after the end of each month, reports will be generated from the main office of the Managing Agent. These reports track monthly expenditures and income by account and compare monthly and year to date results with the annual budget. Computerized bookkeeping services are a WinnResidential central office function designed to aid and expedite the volume and flow of reporting, that otherwise would be performed by a field office staff member. Costs for computerized bookkeeping are included in the basic management fee.

The Managing Agent will prepare, in a timely fashion, monthly and annual reports as required by the regulatory and management agreements, in conformance with federal, state and local agency requirements or the requirements of the property's lenders.

All books, records and accounts shall be maintained at the central office of the Managing Agent, currently located at One Washington Mall, Suite 500, Boston, MA 02108, and will be available for examination at all reasonable times by authorized representatives of the Client. All project files and all resident information will be kept in the site management office.

### **Capital Replacement Plan**

The Client will contract with a capital needs consultant to prepare a long-range capital needs/replacement schedule. The Agent will advise and make recommendations throughout the process and furnish information as requested by the consultant.

Upon written request by the Client, the Agent will have the approved reserve funding deposited into an escrow account designated by the Client. This plan should be updated periodically on a predetermined schedule established by the Client and Agent. No more than 5 (five) years should elapse between capital needs assessments.

### **Green Operations and Maintenance**

From a management perspective, WinnCompanies has a range of proven services and expertise to ensure efficient management and operation of its communities. WinnResidential has developed company-wide green operations and maintenance policies that leverage procurement strategies to ensure responsible decisions, such as purchasing green cleaning products, instituting preventative maintenance schedules, and integrating pest management best practices. In addition, management staff are enrolled in the National Apartment Association's Credential for Green Property Management (CGMP) program. WinnResidential regularly utilizes utility data benchmarking, and commissioning/retro-commissioning as tools to prove scalable, cost-effective investments.

All of Winn's development projects – rehab and new construction – follow green building certification standards such as the U.S. Green Building Council's LEED, Energy Star Multifamily New Construction, Passive House, and Enterprise Green Communities, enhancing the portfolio's energy performance and long-term operations. Additionally, as a large, national property manager, WinnCompanies is constantly investing in efficiency, evaluating new technologies and innovative approaches. Capital planning integrates energy and water conservation goals, strategically improving the portfolio's performance year over year.

Areas that will receive special focus include:

#### **Energy and Water Use Reduction**

- Energy efficient lighting w/motion sensors/timers
- High efficiency HVAC systems with proper controls
- Water saving devices—toilets, showers, aerators
- Energy Star appliance purchasing
- Green landscaping— “greenspace” plantings
  
- Meters for irrigation systems
- Air conditioner sleeve insulation and covers
- Energy efficient laundry equipment

#### **Maintenance Practices**

- Low VOC paints and sealants



- Low VOC kitchen cabinets
- Certified recycled carpet and flooring products and low VOC glues
- Trash recycling
- Hazardous waste recycling
- Green cleaning products—staff and contracted cleaning
- Integrated Pest Management

Also, in the property management office, staff will use recycled products, recycle waste, use Energy Star appliances and equipment and reduce utility consumption. On a monthly basis management will utilize the AUM Utility Module to monitor gas, electricity & water consumption.

## Management Agent Profile

### **WinnResidential**

Recognized as one of the nation's leaders in multifamily housing property management, WinnResidential offers decades of proven third-party experience across all property types and income levels in large and small metropolitan markets from coast to coast. WinnResidential is the largest manager of LIHTC housing and among the largest managers of affordable housing and rental properties in the United States. In partnership with Lendlease, it is also the nation's second-largest manager of privatized military housing.

WinnResidential operates more than 105,673 apartments at 660 sites across 23 states and the District of Columbia. WinnCompanies owns more than 125 properties in this portfolio, totaling nearly 15,500 units, and brings an experienced owner's perspective to the management company. This viewpoint provides insight into compliance, asset management, revenue capture, staffing, and resident services requirements.

The company's shared operational services structure, including accounting, marketing, technology, risk management, and compliance, generates measurable savings. For example, by leveraging the company's national purchasing program, customers can take advantage of preferred relationships with four dozen brand-name suppliers, secure the best possible prices for goods and services, and pass those savings on to its residents.

Multifamily owners retain WinnResidential because of the company's dedication to operational excellence across a wide range of metrics, including capital and operating budgets, NOI optimization, maintenance, emergency response, rent capture, compliance protocols, and award-winning "green" expertise.

WinnResidential has collaborated with owner-developers to construct, deliver, and lease-up rental properties in more than 230 different cities across the nation, offering leasing strategies ranging from pre-leasing to stabilization, financial planning, reporting, marketing support, and branding.

**Exhibit 5.**

**Construction Plans**

# HARBOR VUE

HYANNIS, MA

WINN DEVELOPMENT  
COMPANY

ARCHITECT

**E-ICON**  
ARCHITECTURE  
101 SUMMER ST BOSTON MA 02110

CONSULTANT

STAMP

KEY PLAN

MARK	DATE	DESCRIPTION
PROJECT NUMBER: 223024		
DRAWN BY: Author		
CHECKED BY: Checker		

PROJECT NUMBER: 223024

DRAWN BY: Author

CHECKED BY: Checker

SHEET TITLE

CONTEXT PLAN

A-001



# HARBOR VUE

HYANNIS, MA

WINN DEVELOPMENT  
COMPANY

ARCHITECT

**E-ICON**  
ARCHITECTURE  
101 SUMMER ST BOSTON MA 02110

CONSULTANT

STAMP

KEY PLAN

MARK	DATE	DESCRIPTION
PROJECT NUMBER: 223024		
DRAWN BY: Author		
CHECKED BY: Checker		

SHEET TITLE

SITE IMAGES

A-002



MAIN STREET



THE FEDERATED CHURCH OF HYANNIS



CONFORT INN HYANNIS



MAIN STREET



OLD COLONY RD PARKING ENTRANCE



HYANNIS VILLAGE GREEN ENTRANCE



COMMERCIAL SPACE



307 MAIN STREET HYANNIS



HYATTS ARTIST SHANTIES

# HARBOR VUE

HYANNIS, MA

WINN DEVELOPMENT  
COMPANY

ARCHITECT



CONSULTANT

STAMP

KEY PLAN

MARK	DATE	DESCRIPTION
PROJECT NUMBER: 223024		
DRAWN BY: Author		
CHECKED BY: Checker		

PROJECT NUMBER: 223024

DRAWN BY: Author

CHECKED BY: Checker

SHEET TITLE

ZONING TABLE

A-003

HARBOR VUE	Allowed	Proposed	Comments/Notes
Use	Residential/Commercial	Residential	Proposed use conforms with allowed
Building Type		Apartment	Proposed use conforms with allowed
<b>Lot Dimensions</b>			
Lot Width (Min.)	30 ft	392 ft	Proposed conforms with allowed
Façade Build Out (min): Primary Frontage	80% min.	335'-2"; 85%	Proposed conforms with allowed
Façade Build Out (min): Secondary Frontage	40% min.	180"; 44%	Proposed conforms with allowed
<b>Building Setbacks</b>			
Primary Front Setback Min/Max	0/15ft	5'-0"/12'-6"	Proposed conforms with allowed
Secondary Front Setback	0/15ft	2'-0"/9'-0"	Proposed conforms with allowed
Side Setback	0ft min.	25'-0"	Proposed conforms with allowed
Rear Setback	0ft min.	5'-0"	Proposed conforms with allowed
<b>Building Form</b>			
Building Width	180' max	168'-0"; 165'-10"	Proposed conforms with allowed
Number of Stories	3.5 or 4 max	4	Proposed conforms with allowed
Ground Story Elevation (min.)	10' min	11'-6"	Proposed conforms with allowed
Upper Story Height	10'min	11'-6"	Proposed conforms with allowed
<b>Building Features</b>			
Ground Story Fenestration (min/max)	-	-	Proposed conforms with allowed
Primary Frontage	60% min.	60%	Proposed conforms with allowed
Secondary Frontage	15% min.	40%	Proposed conforms with allowed

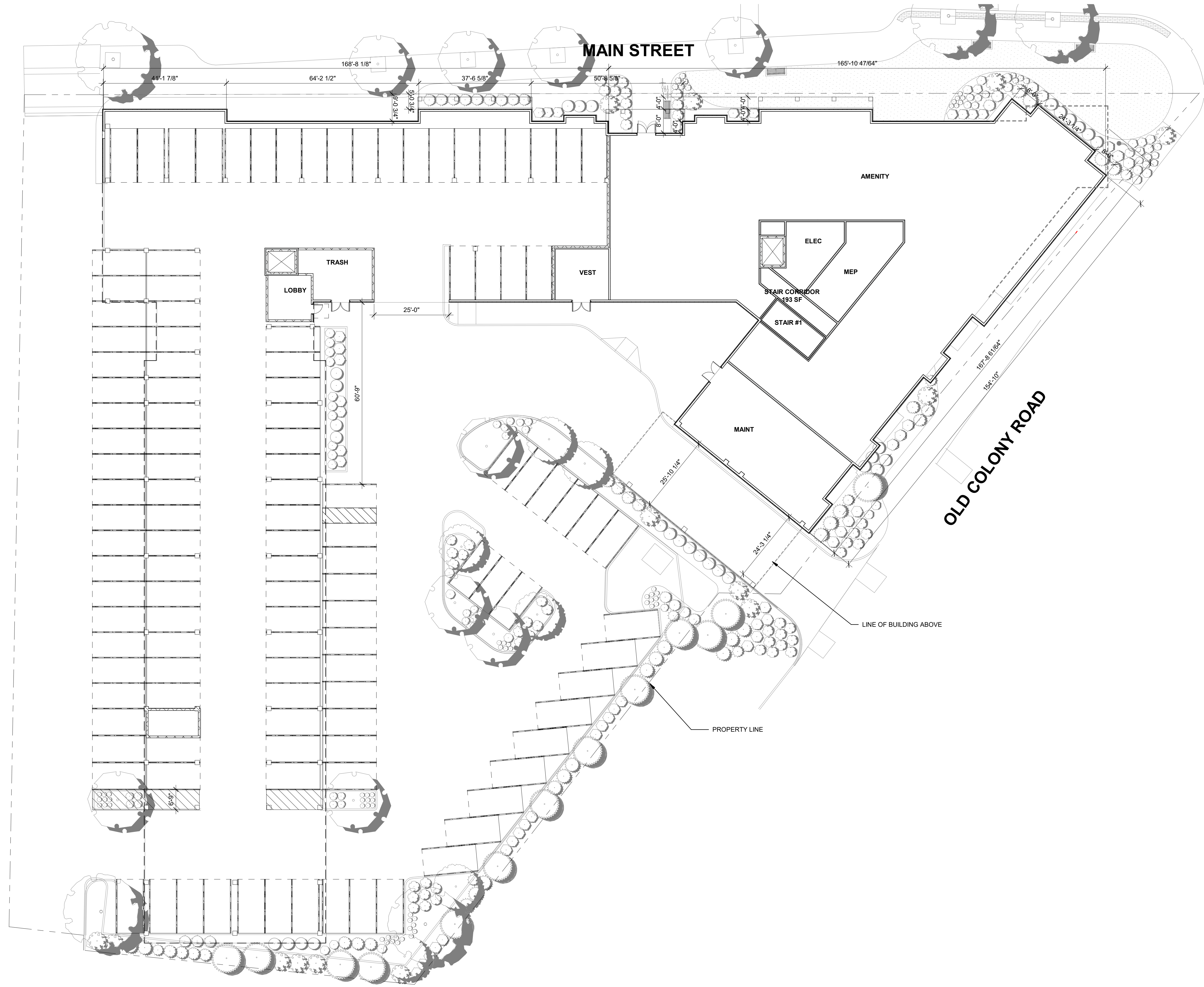

# HARBOR VUE

HYANNIS, MA

WINN DEVELOPMENT  
COMPANY

ARCHITECT

**E-ICON**  
ARCHITECTURE  
101 SUMMER ST BOSTON MA 02110

CONSULTANT

STAMP

KEY PLAN

MARK	DATE	DESCRIPTION
------	------	-------------

PROJECT NUMBER: 223024

DRAWN BY: Author

CHECKED BY: Checker

SHEET TITLE

**LEVEL 1 FLOOR PLAN**

**A-101**

1 LEVEL 1 FLOOR PLAN  
1/16" = 1'-0"

0 8' 16' 32'

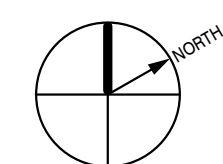

# HARBOR VUE

HYANNIS, MA

WINN DEVELOPMENT COMPANY

ARCHITECT

**E-ICON**  
ARCHITECTURE  
101 SUMMER ST BOSTON MA 02110

CONSULTANT

STAMP

KEY PLAN

MARK	DATE	DESCRIPTION
PROJECT NUMBER: 223024		
DRAWN BY: Author		
CHECKED BY: Checker		

PROJECT NUMBER: 223024

DRAWN BY: Author

CHECKED BY: Checker

SHEET TITLE

LEVELS 2-3 FLOOR PLAN

**A-102**

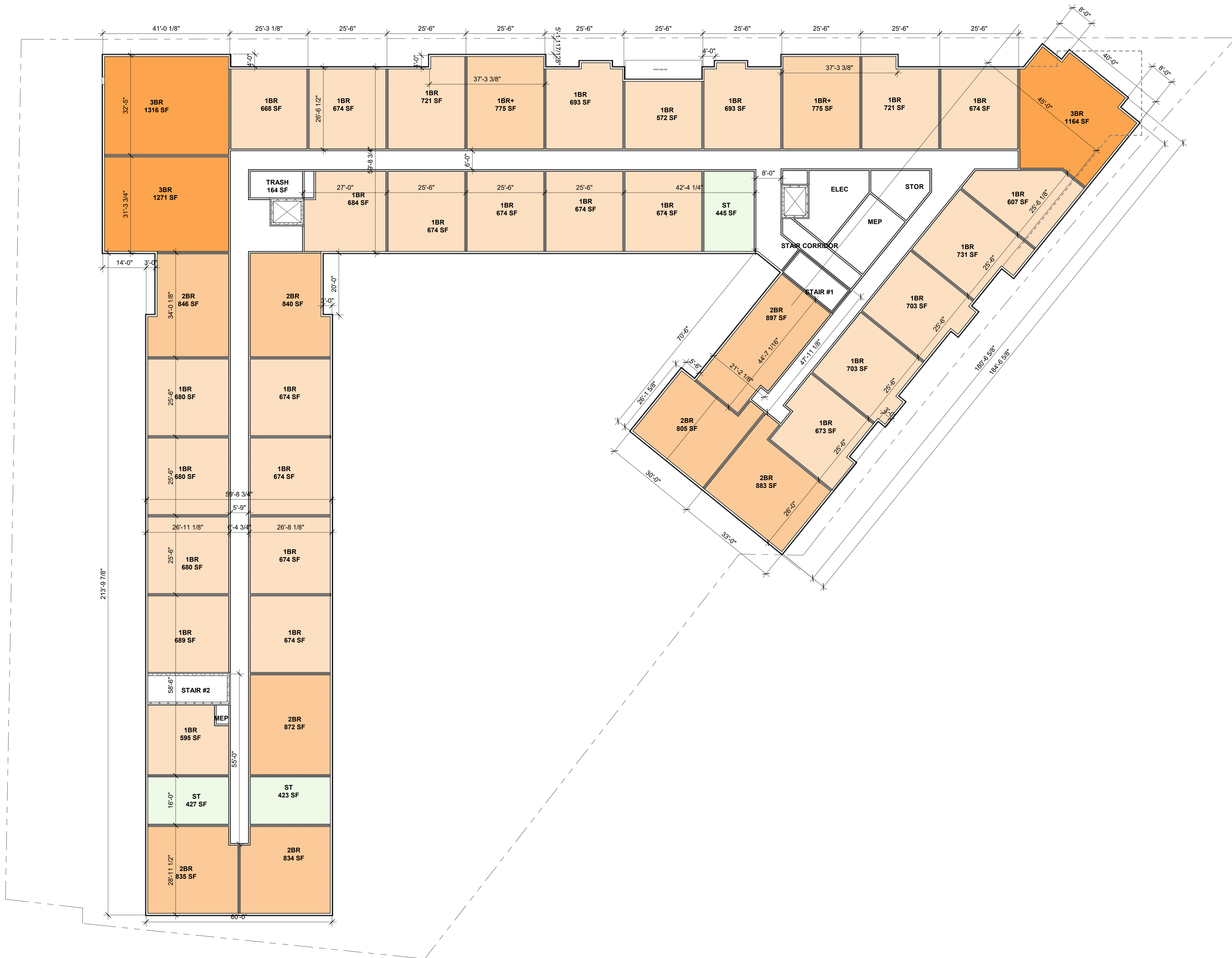

1 LEVEL 2 FLOOR PLAN  
1/16" = 1'-0"

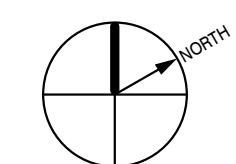
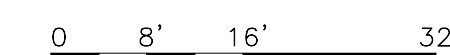

# HARBOR VUE

HYANNIS, MA

WINN DEVELOPMENT COMPANY

ARCHITECT

**E-ICON**  
ARCHITECTURE  
101 SUMMER ST BOSTON MA 02110

CONSULTANT

STAMP

KEY PLAN

MARK	DATE	DESCRIPTION
PROJECT NUMBER: 223024		
DRAWN BY: Author		
CHECKED BY: Checker		

SHEET TITLE

LEVEL 4 FLOOR PLAN

# A-103



1 LEVEL 4 FLOOR PLAN  
1/16" = 1'-0"

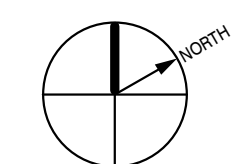
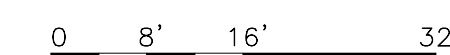



# HARBOR VUE

HYANNIS, MA

WINN DEVELOPMENT  
COMPANY

ARCHITECT

**E-ICON**  
ARCHITECTURE  
101 SUMMER ST BOSTON MA 02110

CONSULTANT

STAMP

KEY PLAN

MARK	DATE	DESCRIPTION
<b>PROJECT NUMBER:</b> 223024		
<b>DRAWN BY:</b> Author		
<b>CHECKED BY:</b> Checker		

**PROJECT NUMBER:** 223024

**DRAWN BY:** Author

**CHECKED BY:** Checker

SHEET TITLE

ROOF PLAN

**A-104**

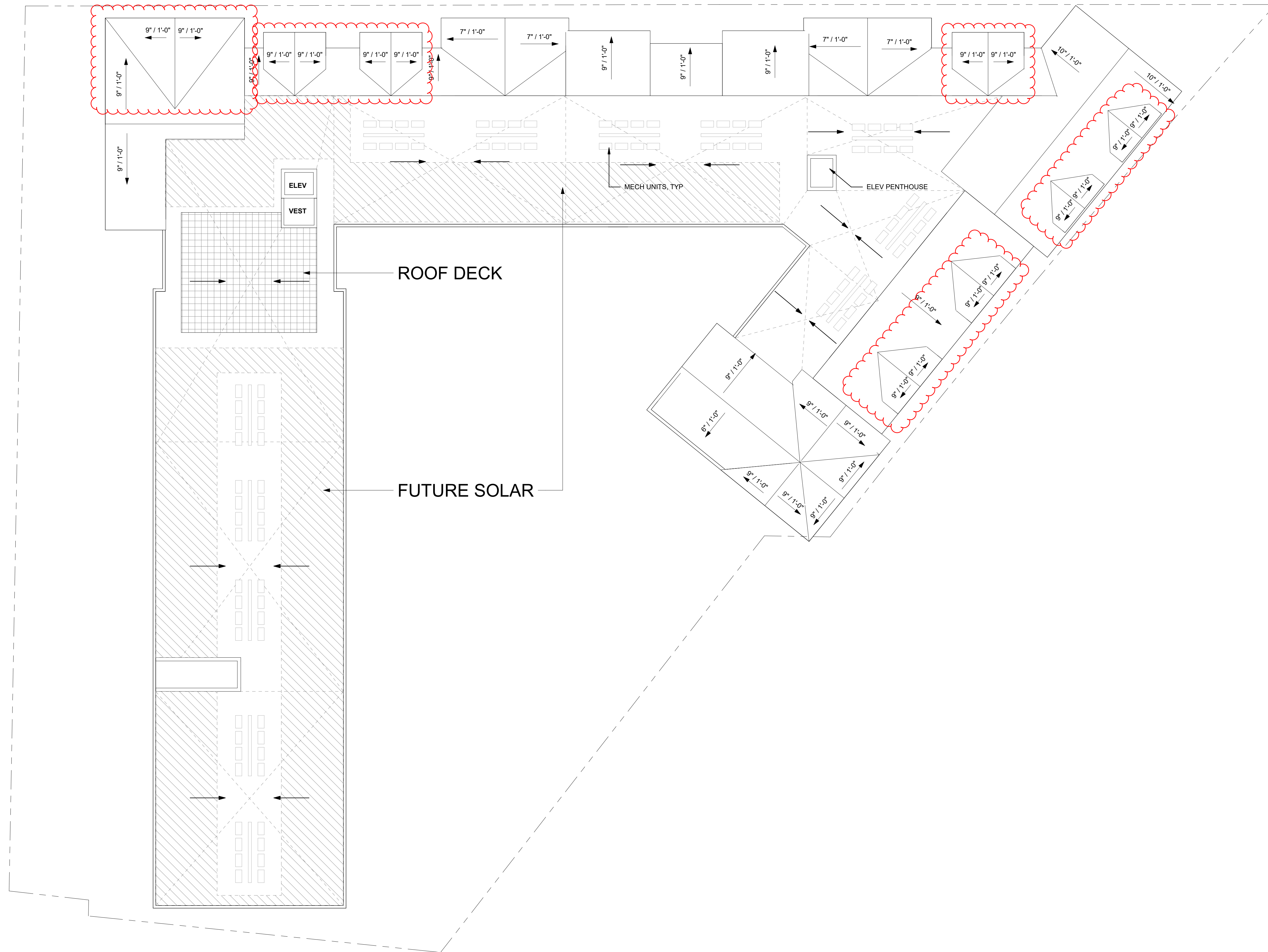

1 ROOF PLAN  
1/16" = 1'-0"

0 8' 16' 32'

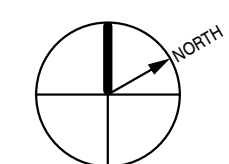



1 NORTH ELEVATION  
1/16" = 1'-0"



2 WEST ELEVATION  
1/16" = 1'-0"



3 EAST ELEVATION  
1/16" = 1'-0"



4 SOUTH ELEVATION  
1/16" = 1'-0"

# HARBOR VUE

HYANNIS, MA

WINN DEVELOPMENT  
COMPANY

ARCHITECT



CONSULTANT

STAMP

KEY PLAN

MARK	DATE	DESCRIPTION
PROJECT NUMBER: 223024		
DRAWN BY: Author		
CHECKED BY: Checker		

PROJECT NUMBER: 223024  
DRAWN BY: Author  
CHECKED BY: Checker

SHEET TITLE

BUILDING  
ELEVATIONS

A-201

# HARBOR VUE

HYANNIS, MA

WINN DEVELOPMENT  
COMPANY

ARCHITECT

**E-ICON**  
ARCHITECTURE  
101 SUMMER ST BOSTON MA 02110

CONSULTANT

STAMP

KEY PLAN

MARK	DATE	DESCRIPTION
PROJECT NUMBER: 223024		
DRAWN BY: Author		
CHECKED BY: Checker		

PROJECT NUMBER: 223024

DRAWN BY: Author

CHECKED BY: Checker

SHEET TITLE

BUILDING SECTIONS

**A-301**



2 SITE SECTION  
1" = 20'-0"

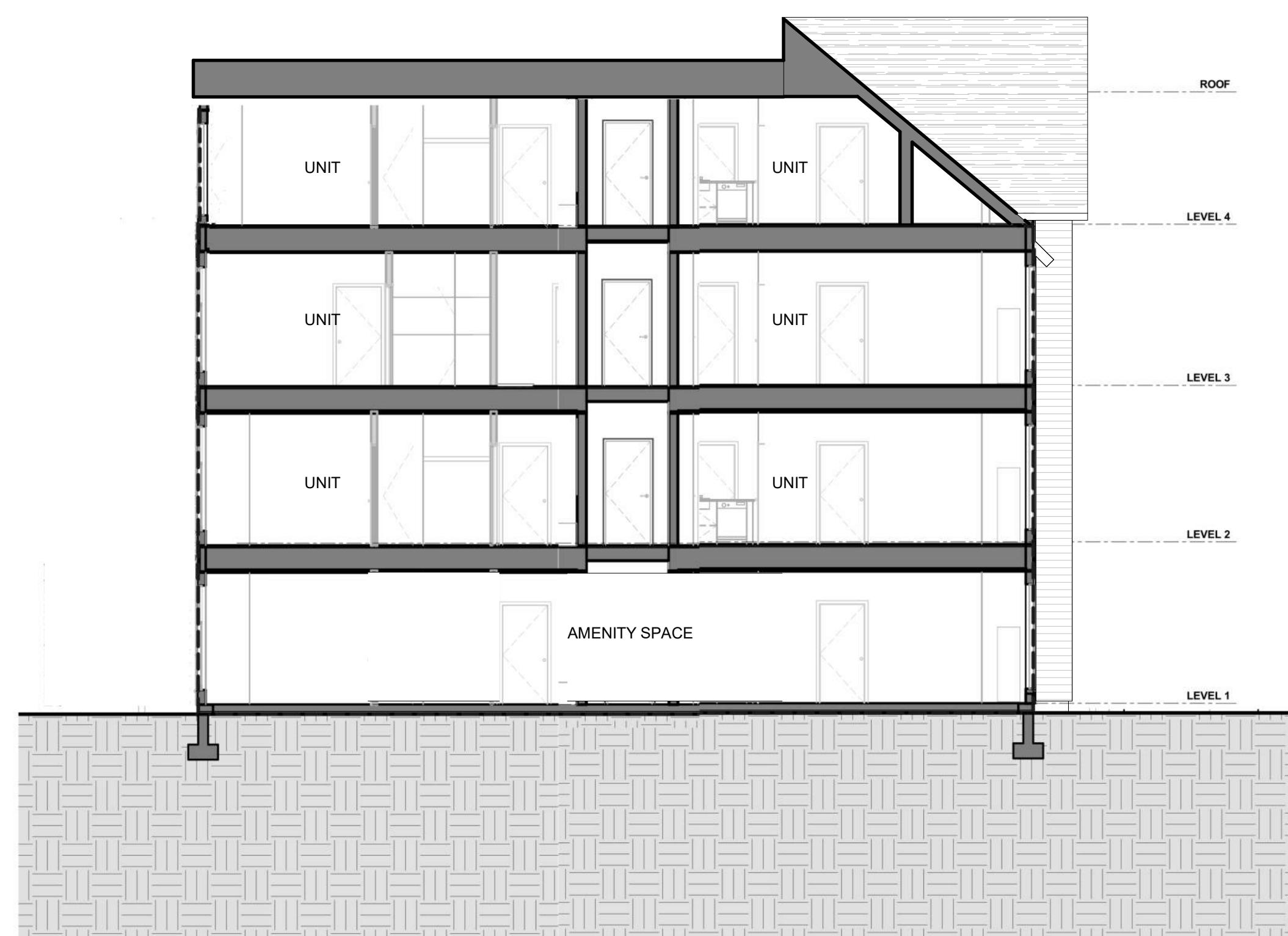

3 BUILDING SECTION 2  
1/8" = 1'-0"

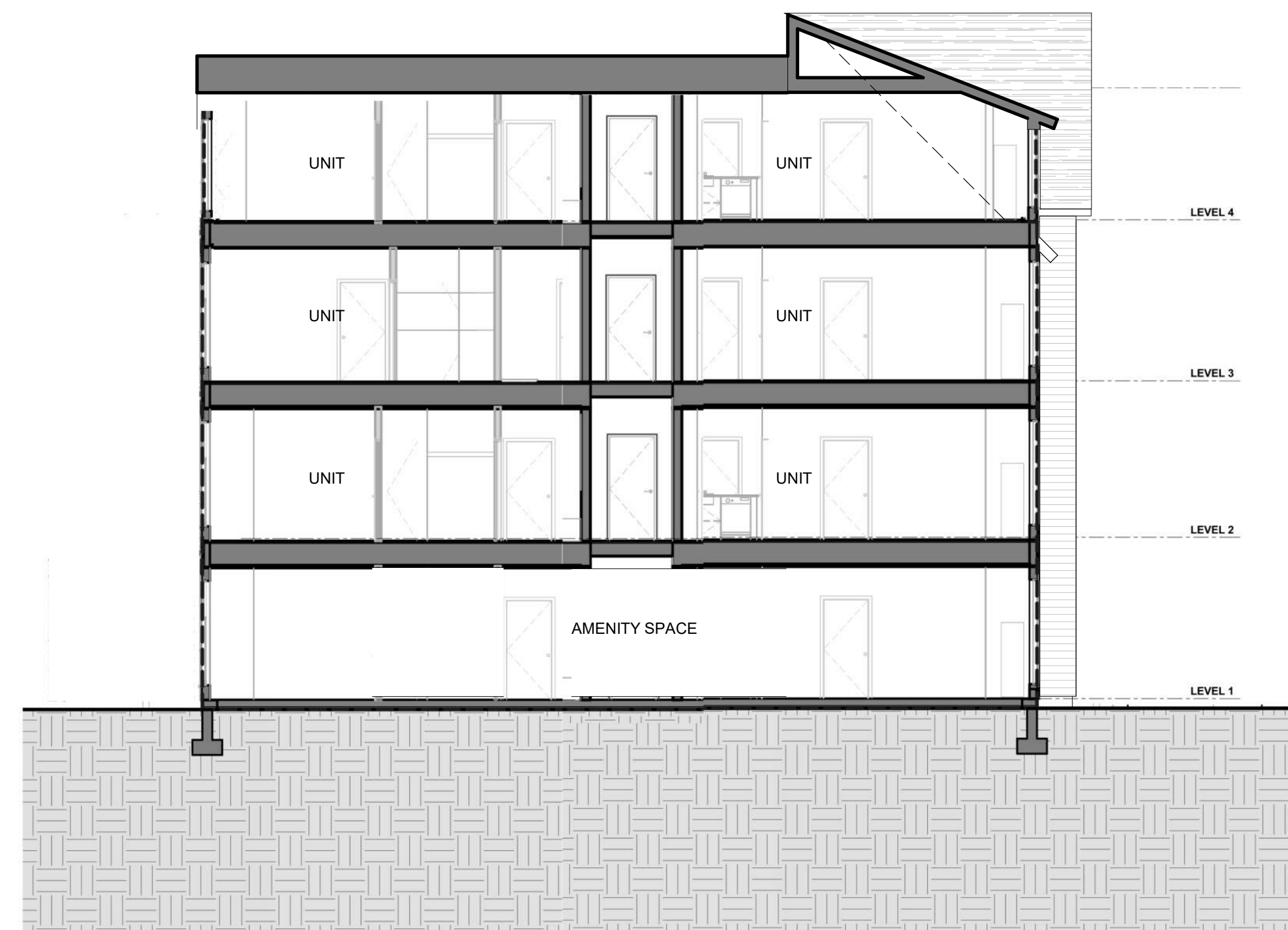

1 BUILDING SECTION 1  
1/8" = 1'-0"

# HARBOR VUE

HYANNIS, MA

WINN DEVELOPMENT  
COMPANY

ARCHITECT

**E-ICON**  
ARCHITECTURE  
101 SUMMER ST BOSTON MA 02110

CONSULTANT

STAMP

KEY PLAN

MARK	DATE	DESCRIPTION
<b>PROJECT NUMBER:</b> 223024		
<b>DRAWN BY:</b> Author		
<b>CHECKED BY:</b> Checker		

**PROJECT NUMBER:** 223024

**DRAWN BY:** Author

**CHECKED BY:** Checker

SHEET TITLE

MATERIALS BOARD

A-302



1 FIBER CEMENT LAP SIDING

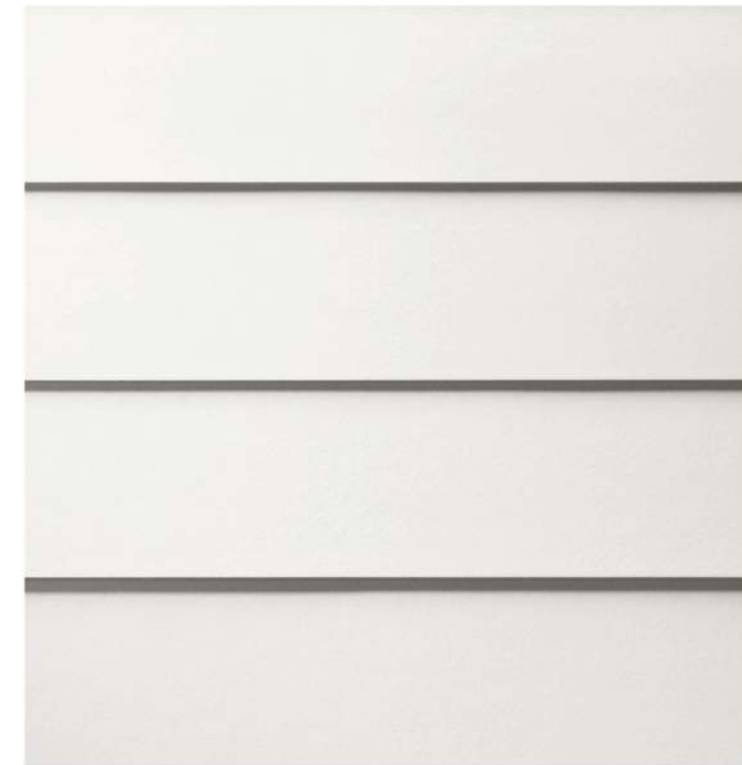

2 COMPOSITE SHINGLES



3 TRIPLE-GLAZED UPVC WINDOWS

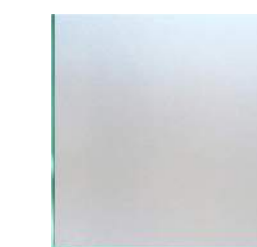
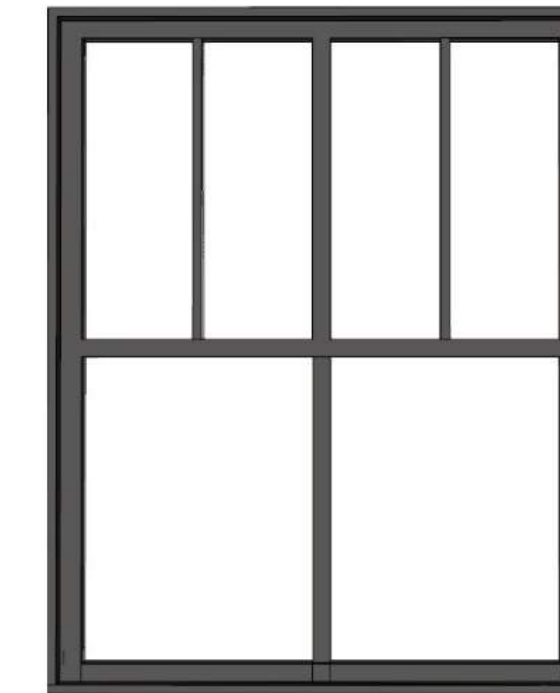

3a FROSTED SPANDREL GLASS AT GARAGE

4 ASPHALT SHINGLE



5 ALUMINUM RAILING

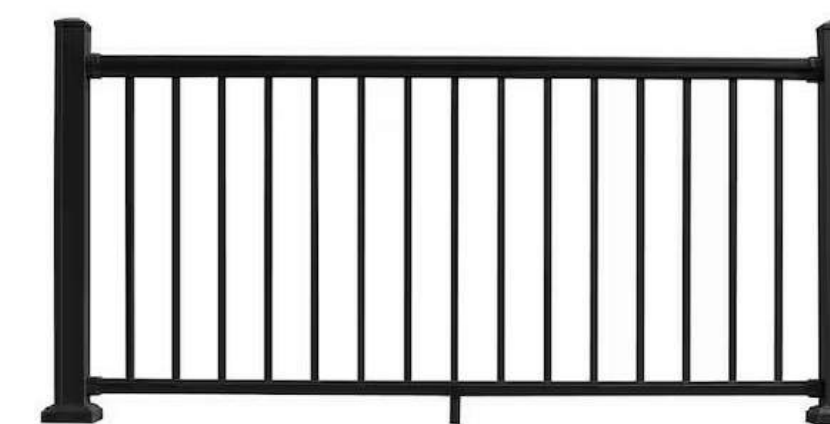

6 BRICK MASONRY VENEER

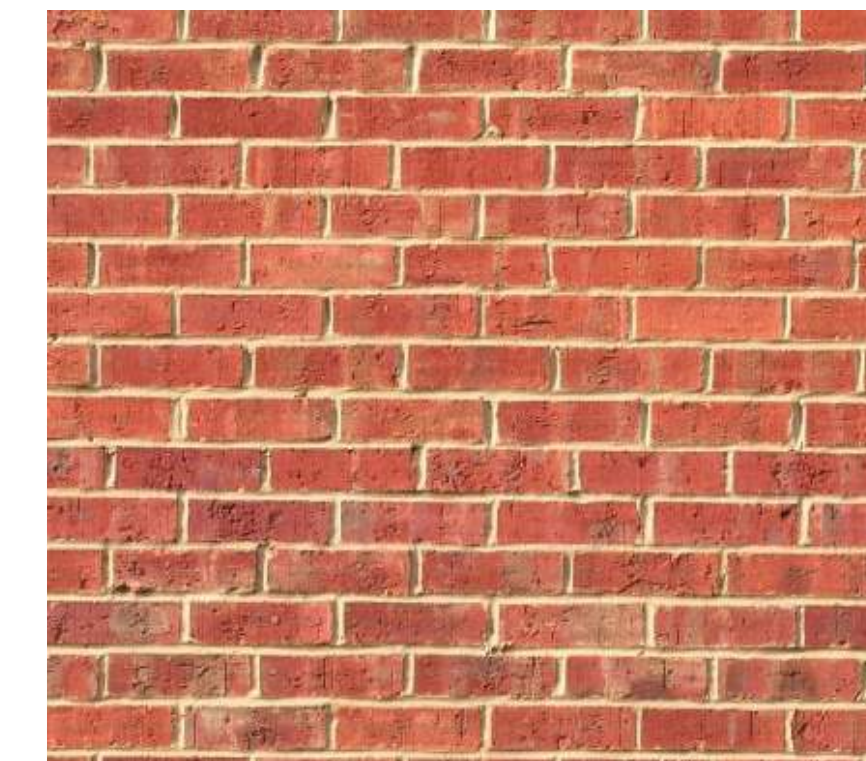

1 MATERIALS  
3/16" = 1'-0"

# HARBOR VUE

HYANNIS, MA

WINN DEVELOPMENT  
COMPANY

ARCHITECT

**E-ICON**  
ARCHITECTURE  
101 SUMMER ST BOSTON MA 02110

CONSULTANT

STAMP

KEY PLAN

MARK	DATE	DESCRIPTION
------	------	-------------

PROJECT NUMBER: 223024

DRAWN BY: Author

CHECKED BY: Checker

SHEET TITLE

PERSPECTIVE  
LOOKING  
SOUTHEAST ON MAIN  
ST

## A-303



# HARBOR VUE

HYANNIS, MA

WINN DEVELOPMENT  
COMPANY

ARCHITECT

**E-ICON**  
ARCHITECTURE  
101 SUMMER ST BOSTON MA 02110

CONSULTANT

STAMP

KEY PLAN

MARK	DATE	DESCRIPTION
------	------	-------------

PROJECT NUMBER: 223024

DRAWN BY: Author

CHECKED BY: Checker

SHEET TITLE

PERSPECTIVE  
LOOKING EAST ON  
MAIN ST

## A-304



# HARBOR VUE

HYANNIS, MA

WINN DEVELOPMENT  
COMPANY

ARCHITECT

**E-ICON**  
ARCHITECTURE  
101 SUMMER ST BOSTON MA 02110

CONSULTANT

STAMP

KEY PLAN

MARK	DATE	DESCRIPTION
------	------	-------------

PROJECT NUMBER: 223024

DRAWN BY: Author

CHECKED BY: Checker

SHEET TITLE

PERSPECTIVE  
LOOKING WEST ON  
MAIN ST

## A-305



# HARBOR VUE

HYANNIS, MA

WINN DEVELOPMENT  
COMPANY

ARCHITECT

**E-ICON**  
ARCHITECTURE  
101 SUMMER ST BOSTON MA 02110

CONSULTANT

STAMP

KEY PLAN

MARK	DATE	DESCRIPTION
------	------	-------------

PROJECT NUMBER: 223024

DRAWN BY: Author

CHECKED BY: Checker

SHEET TITLE

PERSPECTIVE  
LOOKING NORTH ON  
OLD COLONY RD

## A-306





# HARBOR VUE

HYANNIS, MA

WINN DEVELOPMENT  
COMPANY

ARCHITECT

**E-ICON**  
ARCHITECTURE  
101 SUMMER ST BOSTON MA 02110

CONSULTANT

STAMP

KEY PLAN

MARK	DATE	DESCRIPTION
------	------	-------------

PROJECT NUMBER: 223024

DRAWN BY: Author

CHECKED BY: Checker

SHEET TITLE

ENTRY PERSPECTIVE  
ON MAIN STREET

**A-307**



HARBOR VUE  
HYANNIS, MA

WinnDevelopment Company, LP

ARCHITECT



101 SUMMER ST BOSTON MA 02110

CONSULTANT



BEALS AND THOMAS, INC.  
144 Turnpike Road, Suite 210  
Southborough, Massachusetts 01772-2104  
T 508.366.0560 | www.bealsandthomas.com

STAMP

KEY PLAN

FOR PERMITTING ONLY

MARK	DATE	DESCRIPTION
4	10/10/23	HISTORIC COMM.
3	9/25/23	TOWN COMMENTS
2	9/13/23	HISTORIC COMM.
1	7/31/23	SITE PLAN REVIEW

PROJECT NUMBER: 3447.00  
DRAWN BY:  
CHECKED BY:

SHEET TITLE

LAYOUT AND MATERIALS PLAN

SCALE: 1" = 20'

C3.0

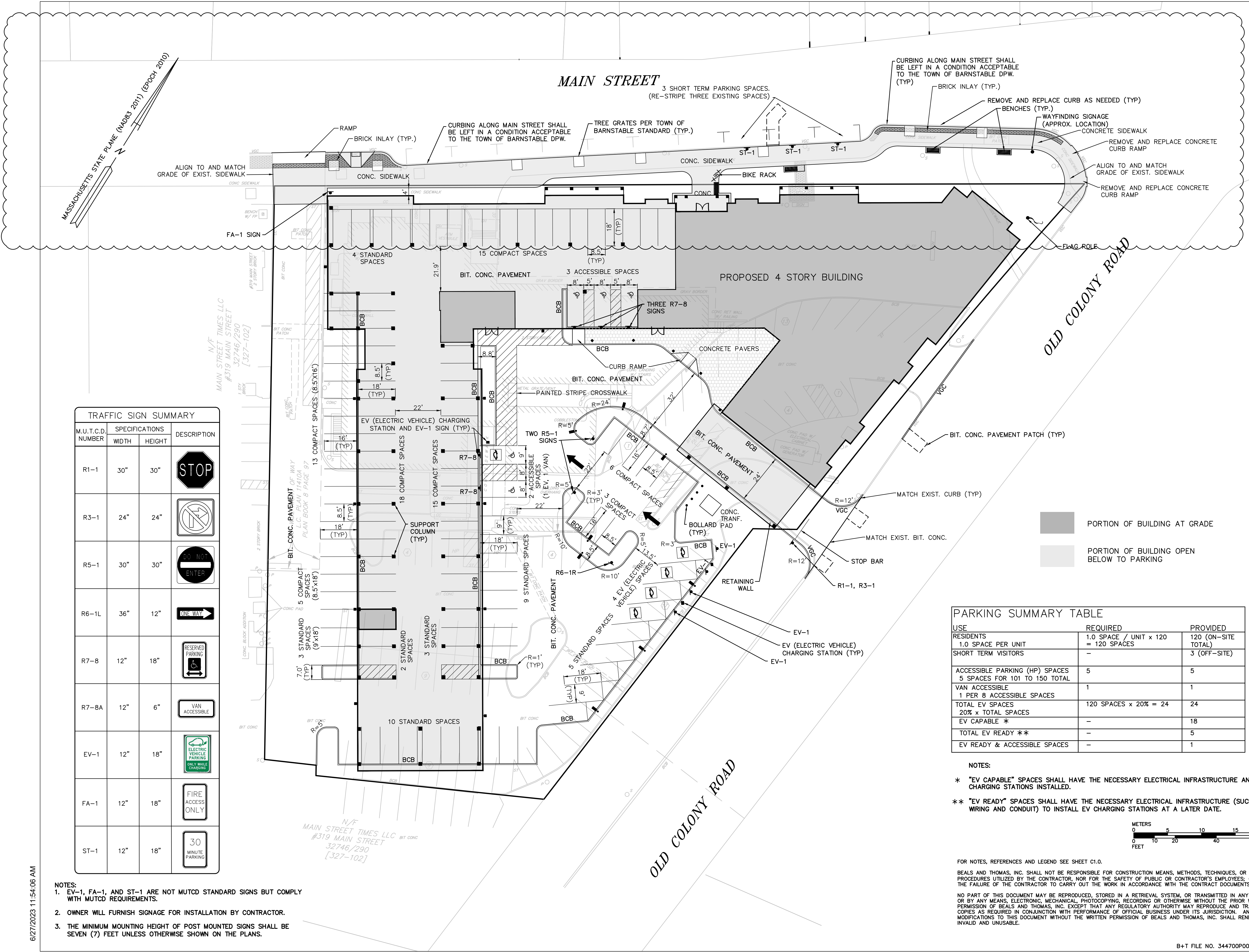

TRAFFIC SIGN SUMMARY

M.U.T.C.D. NUMBER	SPECIFICATIONS	DESCRIPTION	
WIDTH	HEIGHT		
R1-1	30"	30"	
R3-1	24"	24"	
R5-1	30"	30"	
R6-1L	36"	12"	
R7-8	12"	18"	
R7-8A	12"	6"	
EV-1	12"	18"	
FA-1	12"	18"	
ST-1	12"	18"	

PARKING SUMMARY TABLE

USE	REQUIRED	PROVIDED
RESIDENTS	1.0 SPACE / UNIT x 120 = 120 SPACES	120 (ON-SITE TOTAL)
SHORT TERM VISITORS	-	3 (OFF-SITE)
ACCESSIBLE PARKING (HP) SPACES	5	5
5 SPACES FOR 101 TO 150 TOTAL		
VAN ACCESSIBLE	1	1
1 PER 8 ACCESSIBLE SPACES		
TOTAL EV SPACES	120 SPACES x 20% = 24	24
20% x TOTAL SPACES		
EV CAPABLE *	-	18
TOTAL EV READY **	-	5
EV READY & ACCESSIBLE SPACES	-	1

- NOTES:
- \* "EV CAPABLE" SPACES SHALL HAVE THE NECESSARY ELECTRICAL INFRASTRUCTURE AND EV CHARGING STATIONS INSTALLED.
  - \*\* "EV READY" SPACES SHALL HAVE THE NECESSARY ELECTRICAL INFRASTRUCTURE (SUCH AS WIRING AND CONDUIT) TO INSTALL EV CHARGING STATIONS AT A LATER DATE.

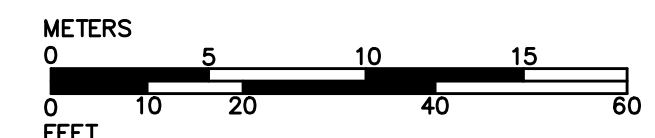

FOR NOTES, REFERENCES AND LEGEND SEE SHEET C1.0.  
BEALS AND THOMAS, INC. SHALL NOT BE RESPONSIBLE FOR CONSTRUCTION MEANS, METHODS, TECHNIQUES, OR PROCEDURES UTILIZED BY THE CONTRACTOR, NOR FOR THE SAFETY OF PUBLIC OR CONTRACTOR'S EMPLOYEES, OR FOR THE FAILURE OF THE CONTRACTOR TO CARRY OUT THE WORK IN ACCORDANCE WITH THE CONTRACT DOCUMENTS.  
NO PART OF THIS DOCUMENT MAY BE REPRODUCED, STORED IN A RETRIEVAL SYSTEM, OR TRANSMITTED IN ANY FORM OR BY ANY MEANS, ELECTRONIC, MECHANICAL, PHOTOCOPYING, RECORDING OR OTHERWISE WITHOUT THE PRIOR WRITTEN PERMISSION OF BEALS AND THOMAS, INC. EXCEPT THAT ANY REGULATORY AUTHORITY MAY REPRODUCE AND TRANSMIT COPIES AS REQUIRED IN CONJUNCTION WITH PERFORMANCE OF OFFICIAL BUSINESS UNDER ITS JURISDICTION. ANY MODIFICATIONS TO THIS DOCUMENT WITHOUT THE WRITTEN PERMISSION OF BEALS AND THOMAS, INC. SHALL RENDER IT INVALID AND UNUSABLE.

6/27/2023 11:54:06 AM

- NOTES:
- EV-1, FA-1, AND ST-1 ARE NOT MUTCD STANDARD SIGNS BUT COMPLY WITH MUTCD REQUIREMENTS.
  - OWNER WILL FURNISH SIGNAGE FOR INSTALLATION BY CONTRACTOR.
  - THE MINIMUM MOUNTING HEIGHT OF POST MOUNTED SIGNS SHALL BE SEVEN (7) FEET UNLESS OTHERWISE SHOWN ON THE PLANS.

# HARBOR VUE

HYANNIS, MA

WinnDevelopment Company, LP

ARCHITECT



101 SUMMER ST BOSTON MA 02110

CONSULTANT



BEALS AND THOMAS, INC.  
144 Turnpike Road, Suite 210  
Southborough, Massachusetts 01772-2104  
T 508.366.0560 | www.bealsandthomas.com

STAMP

KEY PLAN

**FOR PERMITTING ONLY**

4	10/10/23	HISTORIC COMM.
3	9/25/23	TOWN COMMENTS
2	9/13/23	HISTORIC COMM.
1	7/31/23	SITE PLAN REVIEW

MARK	DATE	DESCRIPTION
------	------	-------------

PROJECT NUMBER: 3447.00

**DRAWN BY:**

**CHECKED BY:**

SHEET TITLE

## LANDSCAPE AND LIGHTING PLAN

SCALE: 1" = 20'

# C6.0

### MAIN STREET

### PROPOSED 4 STORY BUILDING

### OLD COLONY ROAD

### OLD COLONY ROAD

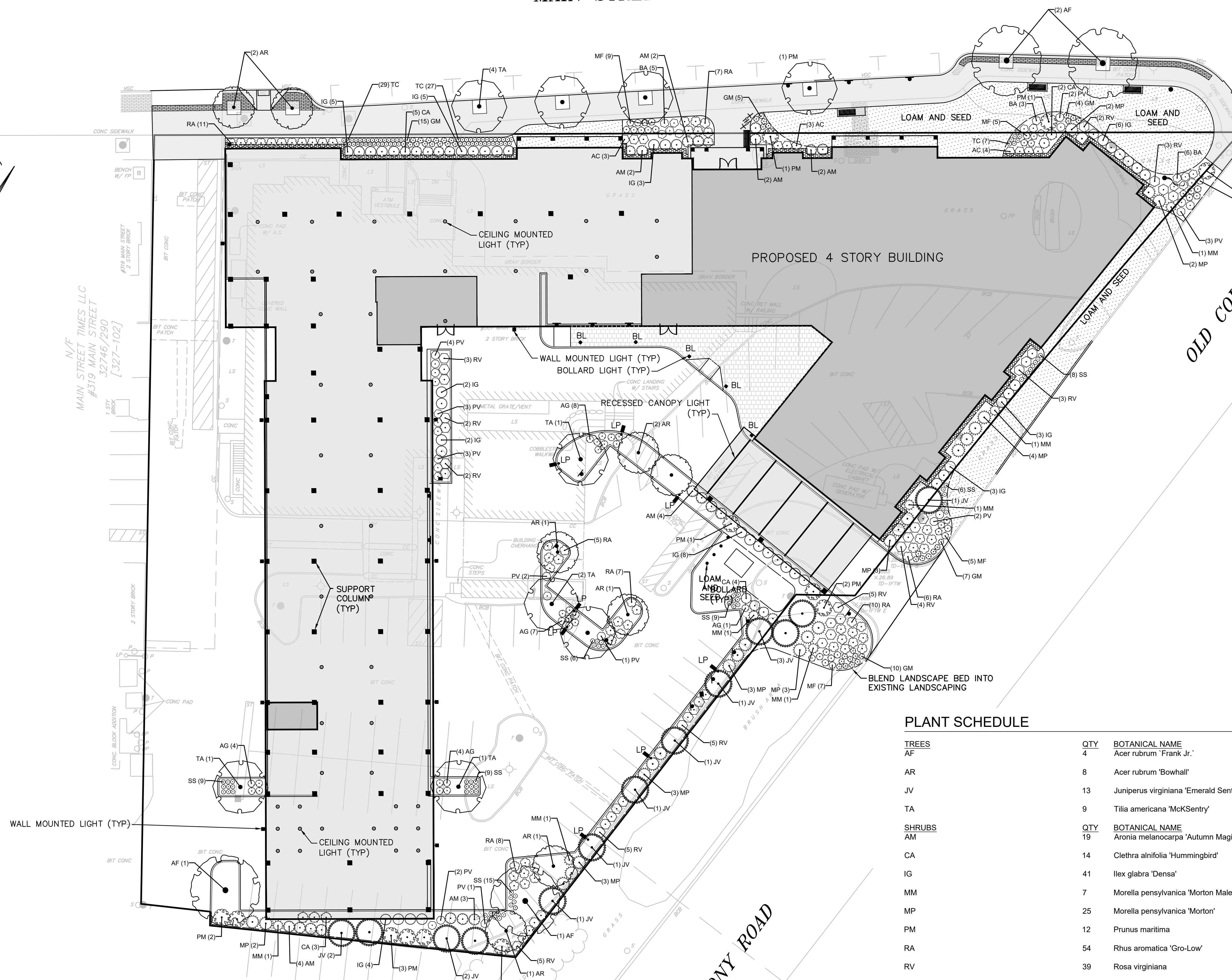

#### PLANT SCHEDULE

TREES	QTY	BOTANICAL NAME	COMMON NAME	SIZE	CONT.
AF	4	<i>Acer rubrum</i> 'Frank Jr.'	Redpointe® Maple	3-3 1/2" cal.	B&B
AR	8	<i>Acer rubrum</i> 'Bowhall'	Bowhall Red Maple	3-3 1/2" cal.	B&B
JV	13	<i>Juniperus virginiana</i> 'Emerald Sentinel'	Emerald Sentinel Red Cedar	7-8' ht.	B&B
TA	9	<i>Tilia americana</i> 'McK Sentry'	American Sentry® Linden	3-3 1/2" cal.	B&B
SHRUBS	QTY	BOTANICAL NAME	COMMON NAME	SIZE	CONT.
AM	19	<i>Aronia melanocarpa</i> 'Autumn Magic'	Autumn Magic Black Chokeberry	24-30" ht.	5 gal.
CA	14	<i>Clethra alnifolia</i> 'Hummingbird'	Hummingbird Summersweet	24-30" ht.	5 gal.
IG	41	<i>Ilex glabra</i> 'Densa'	Inkberry Holly	24-30" ht.	7 gal.
MM	7	<i>Morella pensylvanica</i> 'Morton Male'	Silver Sprite Male Bayberry	24-30" ht.	5 gal.
MP	25	<i>Morella pensylvanica</i> 'Morton'	Silver Sprite Northern Bayberry	30-36" ht.	B&B
PM	12	<i>Prunus maritima</i>	Beach Plum	36-42" ht.	7 gal.
RA	54	<i>Rhus aromatica</i> 'Gro-Low'	Gro-Low Fragrant Sumac	12-18" ht.	3 gal.
RV	39	<i>Rosa virginiana</i>	Virginia Rose	30-36" ht.	7 gal.
PERENNIALS AND ORNAMENTAL GRASSES	QTY	BOTANICAL NAME	COMMON NAME	SIZE	CONT.
AC	10	<i>Actaea racemosa</i>	Black Snakeroot	24-30" ht.	3 gal.
AG	24	<i>Andropogon gerardii</i>	Big Bluestem	24-30" ht.	2 gal.
BA	14	<i>Baptisia australis</i>	Blue Wild Indigo	18-24" ht.	3 gal.
GM	41	<i>Geranium maculatum</i>	Spotted Geranium	8-12" ht.	2 gal.
MF	32	<i>Monarda fistulosa</i>	Bergamot	12-18" ht.	2 gal.
PV	23	<i>Panicum virgatum</i> 'Heavy Metal'	Heavy Metal Switch Grass	24-30" ht.	5 gal.
SS	62	<i>Schizachyrium scoparium</i> 'Jazz'	Jazz Little Bluestem	8-12" ht.	2 gal.
TC	63	<i>Tiarella cordifolia</i>	Foamflower	8-12" ht.	1 gal.

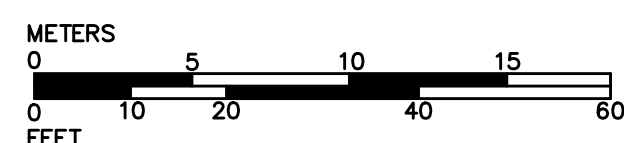

FOR NOTES, REFERENCES AND LEGEND SEE SHEET C1.0.

BEALS AND THOMAS, INC. SHALL NOT BE RESPONSIBLE FOR CONSTRUCTION MEANS, METHODS, TECHNIQUES, OR PROCEDURES UTILIZED BY THE CONTRACTOR, NOR FOR THE SAFETY OF PUBLIC OR CONTRACTOR'S EMPLOYEES; OR THE FAILURE OF THE CONTRACTOR TO CARRY OUT THE WORK IN ACCORDANCE WITH THE CONTRACT DOCUMENTS.

NO PART OF THIS DOCUMENT MAY BE REPRODUCED, STORED IN A RETRIEVAL SYSTEM, OR TRANSMITTED IN ANY FORM OR BY ANY MEANS, ELECTRONIC, MECHANICAL, PHOTOCOPYING, RECORDING OR OTHERWISE WITHOUT THE PRIOR WRITTEN PERMISSION OF BEALS AND THOMAS, INC. EXCEPT THAT ANY REGULATORY AUTHORITY MAY REPRODUCE AND TRANSMIT COPIES AS REQUIRED IN CONJUNCTION WITH PERFORMANCE OF OFFICIAL BUSINESS UNDER ITS JURISDICTION. ANY MODIFICATIONS TO THIS DOCUMENT WITHOUT THE WRITTEN PERMISSION OF BEALS AND THOMAS, INC. SHALL RENDER IT INVALID AND UNUSABLE.

## **Exhibit 6.**

### **Documentation of Funding Commitments**

*\*As noted, we're actively applying for many resources and will have commitments in the coming months.*

**Exhibit 7.**

**Direct Construction Budget**



# Budget Summary

Project Info				
Project Name:	Harbor Vue - Hyannis			
Project Address:	307 Main St.			
Proposal Date:	11/20/2023	Project SF	128,628 sf	
Tax Status:	Taxable	Unit count	120 ea	
Labor Type:	Open Shop			
Design Doc's Dated:	9/25/2023			

Section	Description	Total Cost	Cost/sf	Cost/Unit
	General Requirements	\$ -	\$ -	\$ -
02 41 01	Demolition	\$ 266,871	\$ 2.07	\$ 2,224
02 80 01	Hazardous Materials Abatement - Allowance	\$ 50,000	\$ 0.39	\$ 417
03 10 01	Concrete Turnkey	\$ 2,107,932	\$ 16.39	\$ 17,566
03 54 13	Gypsum Underlayment	\$ 359,771	\$ 2.80	\$ 2,998
04 10 01	Masonry	\$ 1,270,730	\$ 9.88	\$ 10,589
05 12 01	Structural Steel	\$ 2,188,683	\$ 17.02	\$ 18,239
05 55 01	Miscellaneous Metals	\$ 188,708	\$ 1.47	\$ 1,573
06 11 01	Rough Carpentry	\$ 3,394,101	\$ 26.39	\$ 28,284
06 20 01	Finish Carpentry	\$ 804,685	\$ 6.26	\$ 6,706
07 11 01	Waterproofing	\$ 65,272	\$ 0.51	\$ 544
07 20 01	Insulation	\$ 955,915	\$ 7.43	\$ 7,966
07 46 01	Siding	\$ 1,382,459	\$ 10.75	\$ 11,520
07 50 01	Roofing	\$ 1,080,108	\$ 8.40	\$ 9,001
07 81 16	Firestopping and Fire Proofing	\$ 269,826	\$ 2.10	\$ 2,249
07 92 01	Joint Sealants	\$ 60,000	\$ 0.47	\$ 500
08 10 01	Doors/Frames/Hardware	\$ 984,900	\$ 7.66	\$ 8,208
08 41 13	Aluminum Framed Entrances	\$ 205,100	\$ 1.59	\$ 1,709
08 50 01	Windows	\$ 796,015	\$ 6.19	\$ 6,633
09 20 01	Gypsum Board Assemblies	\$ 2,903,709	\$ 22.57	\$ 24,198
09 51 01	Acoustical Ceilings	\$ 185,010	\$ 1.44	\$ 1,542
09 60 01	Flooring	\$ 883,889	\$ 6.87	\$ 7,366
09 91 13	Painting	\$ 521,066	\$ 4.05	\$ 4,342
10 10 01	Specialties	\$ 144,950	\$ 1.13	\$ 1,208
10 14 01	Signage	\$ 45,000	\$ 0.35	\$ 375
11 31 01	Residential Appliances	\$ 696,000	\$ 5.41	\$ 5,800
11 82 01	Trash Chutes & Compactors	\$ 80,500	\$ 0.63	\$ 671
12 20 01	Window Treatments	\$ 75,200	\$ 0.58	\$ 627
12 30 01	Casework	\$ 881,450	\$ 6.85	\$ 7,345
13 10 01	Special Construction - Roof Deck	\$ 278,576	\$ 2.17	\$ 2,321
14 20 01	Elevators	\$ 406,000	\$ 3.16	\$ 3,383
21 10 01	Fire Suppression Systems	\$ 722,602	\$ 5.62	\$ 6,022
22 10 01	Plumbing	\$ 3,531,906	\$ 27.46	\$ 29,433
23 10 01	HVAC	\$ 4,110,838	\$ 31.96	\$ 34,257
26 10 01	Electrical	\$ 5,478,573	\$ 42.59	\$ 45,655
31 10 01	Earthwork	\$ 3,883,898	\$ 30.19	\$ 32,366
32 90 01	Landscaping	\$ 478,496	\$ 3.72	\$ 3,987
-	Allowances	\$ -	\$ -	\$ -

<b>Total Direct Cost of Work</b>		\$ 41,738,736	\$ 324.49	\$ 347,823
----------------------------------	--	---------------	-----------	------------

General Conditions	8.0%	\$ 3,339,099	\$ 25.96	\$ 27,826
Overhead	3.0%	\$ 1,252,162	\$ 9.73	\$ 10,435
Construction Contingency	0.0%	\$ -	\$ -	\$ -
Design Contingency	2.5%	\$ 1,158,250	\$ 9.00	\$ 9,652
Bonds	0.0%	\$ -	\$ -	\$ -
Insurance (GL, Pollution, Auto, Workers Comp.)	0.8%	\$ 379,906	\$ 3	\$ 3,166
Building Permit Fee		\$ 212,968	\$ 2	\$ 1,775
Fee	3.0%	\$ 1,436,045	\$ 11.16	\$ 11,967

<b>Total Construction Cost of Work</b>		\$ 49,517,165	\$ 384.96	\$ 412,643
--	--	---------------	-----------	------------

## 307 Main Street - Project Total

### Development Budget

	Total Budget	
	Total	\$/Unit
<b>Acquisition</b>		
Purchase Price	\$ 5,100,000	\$ 42,500
Broker Fee / Other Acquisition Cost	595,170	4,960
<b>Acquisition</b>	<b>\$ 5,695,170</b>	<b>\$ 129,436</b>
<b>Design</b>		
Building Architecture	\$ 2,185,271	\$ 18,211
Civil Engineer	300,000	2,500
Energy Consultant	300,000	2,500
Geotech Testing	75,000	625
Survey	25,000	208
<b>Design</b>	<b>\$ 2,885,271</b>	<b>\$ 24,044</b>
<b>Construction</b>		
Building Construction - Structures	\$ 41,738,736	\$ 347,823
Other	-	-
<b>Hard Construction Subtotal</b>	<b>\$ 41,738,736</b>	<b>347,823</b>
General Conditions	3,339,099	27,826
Contractor Contingency	1,158,250	9,652
<b>Subtotal</b>	<b>\$ 46,236,085</b>	<b>\$ 385,301</b>
Contractor Overhead/Profit	1,252,162	10,435
Construction Subtotal (excl. Contingency)	\$ 47,488,247	\$ 395,735
Hard Cost Contingency	3,799,060	31,659
<b>Construction</b>	<b>\$ 51,287,307</b>	<b>\$ 427,394</b>
<b>Administrative Expenses</b>		
Inspecting Engineer	\$ 10,000	\$ 83
Inspecting Engineer - DHCD	30,000	250
Environmental Reports	50,000	417
Legal: Organization	425,000	3,542
Title & Recording	90,000	750
Accounting & Cost Cert.	75,000	625
Appraisal & Market Study	45,333	378
Utility Tap/Fees	100,000	833
Site Plan Approval Fee (off-site work)	275,000	2,292
<b>Administrative Expenses</b>	<b>\$ 1,100,333</b>	<b>\$ 9,169</b>
<b>Financing</b>		
Construction Loan Interest	\$ 6,199,566	\$ 51,663
TE Bridge Loan Interest	\$ 597,681	\$ 4,981
Carry Cost	241,500	2,013
Lender Legal Fees (Construction & Perm)	25,000	208
Lender Legal Fees (Subordinate)	25,000	208
Financing Fees	1,009,896	8,416
Syndicator Due Diligence Costs/Fees	40,000	333
<b>Financing</b>	<b>\$ 8,930,939</b>	<b>\$ 74,424</b>
<b>Taxes &amp; Insurance</b>		
Real Estate Taxes	\$ 188,703	\$ 1,573
P&P Bond Premium	393,131	3,276
Builders Risk Insurance	650,000	5,417
<b>Taxes &amp; Insurance</b>	<b>\$ 1,231,833</b>	<b>\$ 10,265</b>
<b>Capitalized Reserves</b>		
Operating Deficit Reserve	\$ 1,028,271	\$ 8,569
Social Service Reserve	100,000	833
Initial Replacement Reserve Deposit	88,000	733
<b>Capitalized Reserves</b>	<b>\$ 1,216,271</b>	<b>\$ 10,136</b>
<b>Miscellaneous/Other Costs</b>		
FF & E	\$ 350,000	\$ 2,917
Security	100,000	833
Operating Loss	134,167	1,118
Fiber/TelData	250,000	2,083
Initial Lease-up/Marketing	240,000	2,000
<b>Miscellaneous/Other Costs</b>	<b>\$ 1,074,167</b>	<b>\$ 8,951</b>
<b>Contingency</b>		
Soft Cost Contingency	\$ 388,719	\$ 3,239
<b>Contingency</b>	<b>\$ 388,719</b>	<b>\$ 3,239</b>
<b>Developer Fee &amp; Overhead</b>		
Developer Fee	\$ 3,044,412	\$ 25,370
Developer Overhead	3,044,412	25,370
<b>Developer Fee &amp; Overhead</b>	<b>\$ 6,088,823</b>	<b>\$ 50,740</b>
<b>Total Development Cost / Eligible Basis</b>	<b>\$ 79,898,833</b>	<b>\$ 665,824</b>

**Exhibit 8.**

**Development Pro-Forma**





**Exhibit 8 b.**

**Rent Grid**

### 307 Main Street - Project Total

Projected Rents - Exhibit 8 b.

Unit Mix - Project Summary							
	10	4	75	26	5	Total	%
	Studio	Jr 1 Bed	1 Bed	2 Bed	3 Bed	87,612	Total
<b>Average Size (SF)</b>	<b>473</b>	<b>829</b>	<b>689</b>	<b>826</b>	<b>1,283</b>		
Market Rents	1		9	1		11	9%
Workforce/Middle-Income @ 120% AMI	2	1	19	10		32	27%
LIHTC 60% Rents	5	3	29	7	1	45	38%
DHCD MRVP @ 100% FMR	1		9	4	2	16	13%
DHCD PBV @ 110% FMR	1		9	4	2	16	13%
<b>Total</b>	<b>10</b>	<b>4</b>	<b>75</b>	<b>26</b>	<b>5</b>	<b>120</b>	<b>100%</b>

Market Rents					
	Studio	Jr 1 Bed	1 Bed	2 Bed	3 Bed
Market Rents	\$1,850	\$2,150	\$2,250	\$2,650	\$3,300
Utility Allowance					
Maximum Adjusted Rent	\$1,850	\$2,150	\$2,250	\$2,650	\$3,300
Percent of Max	90%	90%	90%	90%	90%
<b>Market Rent</b>	<b>\$1,665</b>	<b>\$1,935</b>	<b>\$2,025</b>	<b>\$2,385</b>	<b>\$2,970</b>

Workforce/Middle-Income @ 120% AMI					
	Studio	Jr 1 Bed	1 Bed	2 Bed	3 Bed
Workforce/Middle-Income @ 120% AMI	\$2,217	\$2,532	\$2,532	\$2,849	\$3,165
Utility Allowance					
Maximum Adjusted Rent	\$2,217	\$2,532	\$2,532	\$2,849	\$3,165
Percent of Max	70%	70%	72%	76%	82%
<b>Workforce/Middle-Income @ 120% AMI</b>	<b>\$1,552</b>	<b>\$1,773</b>	<b>\$1,823</b>	<b>\$2,165</b>	<b>\$2,595</b>

LIHTC 60% Rents					
	Studio	Jr 1 Bed	1 Bed	2 Bed	3 Bed
LIHTC 60% Rents	\$1,209	\$1,381	\$1,381	\$1,554	\$1,726
Utility Allowance	\$78	\$91	\$118	\$143	
Maximum Adjusted Rent	\$1,131	\$1,290	\$1,263	\$1,411	\$1,726
Percent of Max	95%	95%	95%	95%	95%
<b>LIHTC 60% AMI Rent</b>	<b>\$1,074</b>	<b>\$1,226</b>	<b>\$1,200</b>	<b>\$1,340</b>	<b>\$1,640</b>

DHCD MRVP @ 100% FMR					
	Studio	Jr 1 Bed	1 Bed	2 Bed	3 Bed
DHCD MRVP @ 100% FMR	\$1,486	\$1,585	\$1,585	\$2,082	\$2,541
Utility Allowance	\$78	\$91	\$118	\$143	
Maximum Adjusted Rent	\$1,408	\$1,494	\$1,467	\$1,939	\$2,541
Percent of Max	100%	100%	100%	100%	100%
<b>EOHLC PBV @ 100% FMR Rent</b>	<b>\$1,408</b>	<b>\$1,494</b>	<b>\$1,467</b>	<b>\$1,939</b>	<b>\$2,541</b>

DHCD PBV @ 110% FMR					
	Studio	Jr 1 Bed	1 Bed	2 Bed	3 Bed
DHCD PBV @ 110% FMR	\$1,635	\$1,744	\$1,744	\$2,290	\$2,795
Maximum Adjusted Rent	\$1,557	\$1,653	\$1,626	\$2,147	\$2,795
Percent of Max	100%	100%	100%	100%	100%
<b>EOHLC PBV @ 110% FMR Rent</b>	<b>\$1,557</b>	<b>\$1,653</b>	<b>\$1,626</b>	<b>\$2,147</b>	<b>\$2,795</b>

## **Exhibit 9.**

### **Developer Team Resumes & Qualifications**



**Gilbert Winn**  
**Chief Executive Officer**  
**WinnCompanies**

Gilbert J. Winn is the Chief Executive Officer of WinnCompanies, an award-winning national multifamily development and management company dedicated to the highest standards of excellence. He develops, plans, implements, and integrates the company's strategic goals on behalf of 3,800 employees across 23 states and the District of Columbia. Mr. Winn oversees the organization's three divisions: WinnResidential, one of the nation's largest multifamily and affordable housing managers operating 630 apartment communities for 65,000 households of all incomes in 17 states and the District of Columbia; WinnDevelopment, responsible for creating more than 15,000 apartments and 1.3 million square feet of commercial space and

a national leader in historic adaptive reuse; and, WinnResidential Military Housing Services, a leading manager of privatized military housing for 40,454 members of the U.S. Armed Forces and their families in 12 states.

Since becoming CEO in 2015, Mr. Winn has led the company's growth by advancing high-impact mixed-income and mixed-use development projects, many of which have received awards for their contributions to the community, design, sustainable features, and historic preservation. He has built an empowered, client-driven organization, investing heavily in employee training, recruiting, and retention, housing stability strategies for at-risk tenants, and diversity, equity, and inclusion initiatives. He was named to the Affordable Housing Finance Magazine Hall of Fame in 2022.

Under his leadership, the company's owned portfolio has grown to 125 apartment communities, created through new construction or acquisition in 11 states and Washington, DC.

Before joining WinnCompanies in 2003, he was an associate at Related Capital Company, a full-service real estate investment company based in New York City, where he originated and implemented more than \$150 million of equity investments.

Mr. Winn graduated magna cum laude from the University of Pennsylvania, where he earned a Bachelor of Arts studying history and psychology. He lives in Boston with his wife and two children and actively supports numerous charitable and civic causes.



**Lawrence H. Curtis**  
**President & Managing Partner**  
**WinnDevelopment**

Lawrence H. Curtis, the President and Managing Partner of WinnDevelopment and a member of the Board of Directors, has led a full range of real estate development and acquisition activities for more than 35 years. He has been instrumental in helping the company grow from 3,000 units in 1986 to more than 103,000 units, which Winn currently has under management in 23 states and the District of Columbia.

Mr. Curtis' primary focus has been on the creation of affordable housing and historic rehabilitation developments. He is a past president of the National Housing & Rehabilitation Association (NH&RA), a member of the Board of Directors for the National Multi-Housing Council, and a Trustee Emeritus of the National Trust for Historic Preservation's Board of Trustees. Mr. Curtis served as the 2006 chairman of the Greater Boston Real Estate Board (GBREB) and as co-chair of the Combined Jewish Philanthropies' annual campaign in 2008. He has also received numerous awards, including the Paul E. Tsongas Award from Preservation Massachusetts. In addition, Mr. Curtis co-founded New Lease, a non-profit based in Boston that provides a clearinghouse of affordable housing units for families staying in state-funded shelters and motels throughout Massachusetts.

Mr. Curtis received a bachelor's degree in Architecture from the Cooper Union for the Advancement of Science and Art in New York and a master's degree in Architecture and Urban Design from Harvard University, where he is a Lecturer in the Master's of Real Estate Program. He is a licensed architect in Massachusetts with national NCARB certification.



**Michael O'Brien**  
**Executive Vice President**  
**WinnCompanies**

Michael O'Brien, Executive Vice President, has been part of the Winn Executive Team since January 2014.

In his role, Mr. O'Brien is responsible for corporate management, strategic planning, and financial and client relationships at WinnDevelopment and WinnResidential.

Prior to joining Winn, Mr. O'Brien spent nine years as the City Manager of Worcester. During that time, Mr. O'Brien successfully implemented multiple programs to spur economic development and improve neighborhoods. As a result, Worcester is currently rated one of the safest communities in the country, among cities with a population of 100,000 or more, and is experiencing more than \$1.3 billion in planned or current economic development activity.

Additionally, Mr. O'Brien spearheaded "Buy Worcester Now," a new private-public partnership between the city, banks, lending institutions, local companies, non-profit agencies, realtors and the Commonwealth of Massachusetts to generate new market demand for all available housing options in Worcester and to assist qualified, responsible buyers in purchasing a home. He also established five Neighborhood Revitalization Strategy Areas, each focused specifically on issues relative to housing, code enforcement, commercial storefront improvements and job training.

Mr. O'Brien received a Bachelor of Science degree from the University of Massachusetts Amherst.



**Adam Stein**  
**Executive Vice President**  
**WinnDevelopment**

Adam joined WinnCompanies in 2009 and currently serves as Executive Vice President of WinnDevelopment where he is responsible for overseeing the company's development initiatives across New England and upstate New York.

Mr. Stein has nearly two decades of experience in multi-family real estate development in the areas of new construction, acquisition rehabs and adaptive reuse and has been responsible for the successful creation of more than \$700 million of real estate investments in various communities across the Eastern U.S. Prior to joining WinnCompanies, Mr. Stein served as a Development Manager at JPI Northeast, a conventional multi-family development company based in Irving, Texas and as Vice President of Development for the Norsouth Companies, a housing developer, general contractor and manager of mixed-income and mixed-use properties throughout the Southeast.

Mr. Stein earned his MBA from Georgia State University's J. Mack Robinson College of Business, an MFA in Historic Preservation from The Savannah College of Art & Design and a BA from Union College. He is also an active member of the Urban Land Institute's Boston chapter, NH&RA and holds his Massachusetts Real Estate License.





**David W. Thunell**  
**Senior Vice President of Construction**  
**WinnDevelopment**

David W. Thunell, Senior Vice President of Construction, has served WinnDevelopment as an experienced construction professional since 2005. David's extensive knowledge of the construction industry includes expertise in budget analysis, project management, value engineering, constructability reviews, quality control, and project closeouts. David also maintains exceptional contractor and client relationships. All of these best practices have led WinnDevelopment to win various LEED accreditations, Historical Preservation Awards, and Energy Conservation Incentives.

WinnDevelopment's most recent achievements under Mr. Thunell's direction include: Oliver Lofts, a historic adaptive reuse mill which obtained LEED construction Platinum rating; Castle Square Midrise Apartments, a deep energy solar thermal project, which received a LEED Platinum rating; and Malden Mills, a historic adaptive reuse mill that is LEED certifiable.

Prior to joining WinnDevelopment, Mr. Thunell served as Vice President of Properties and Director of Engineering, Construction & Maintenance for 16 years at Filene's-Kaufmanns, May Companies. Preceding that, David was Chief Engineer for Apex Oil/BP-Sohio.

Mr. Thunell has a Bachelor of Science in Engineering from Massachusetts Maritime Academy.



**Timothy Mustacato**  
**Director of Acquisitions**  
**WinnDevelopment**

Tim Mustacato has been with WinnCompanies for nearly a decade, most recently serving as an Acquisition Associate. Mr. Mustacato began with the company as a Project Financial Analyst with the finance and asset management team. While on the team, he was responsible for the underwriting, diligence and closing of more than \$200 million in financing.

In his current role as Director of Acquisitions, Mr. Mustacato is responsible for identifying potential development, acquisition and investment opportunities in WinnCompanies' core markets, as well as identifying potential new markets for multifamily ownership opportunities.

Mr. Mustacato holds a bachelor's degree in Marketing and Management from Northeastern University and is an active member of the Greater Boston Real Estate Board's Real Estate Finance Association (REFA).



**Ramie Schneider**  
**Associate Vice President**  
**WinnDevelopment**

Ramie joined WinnDevelopment in 2021 and has nearly a decade of ground up, market rate residential experience. She currently serves as a Senior Project Director, managing a variety of projects in the New England region.

Prior to joining WinnCompanies, Ramie worked at HYM Investment Group overseeing the 161 acre Suffolk Downs redevelopment Project. In addition, Ramie previously worked for the Bozzuto Group on their development team overseeing ground up construction projects in the Mid Atlantic and Boston regions.

Ramie holds a Bachelors of Science in Business Administration Degree with a Concentration in Real Estate from Boston University. Ramie is member of ULI Boston and NH&RA.



**Christina McPike**  
**Director of Energy & Sustainability**  
**WinnDevelopment**

Christina McPike manages various energy efficiency and sustainability projects for the WinnCompanies portfolio. During her seven years at WinnCompanies, Ms. McPike has coordinated and implemented nearly \$20 million worth of energy efficiency upgrades, including, but not limited to, LED lighting retrofits, weatherization work, and heating system installations. With Ms. McPike's expertise and cross-disciplinary approach, WinnDevelopment successfully integrates energy and sustainability goals and targets into every project, from occupied moderate renovations to historic adaptive reuse projects.

Ms. McPike has experience working with grant agencies and utility companies in D.C., Massachusetts, Connecticut, and New York where she manages several projects, including those pursuing Enterprise Green Communities, Energy Star, and LEED certifications. In addition to supporting acquisition rehab projects, Ms. McPike also often interfaces with WinnResidential property and asset management staff on energy retrofit opportunities, energy usage benchmarking, resident engagement, and green operations and maintenance.

Ms. McPike is a member of the Northeast Sustainable Energy Association, where she received the Kate Goldstein Fund award in 2016, and has participated in numerous speaking engagements with NESEA. Ms. McPike is also a member of the Massachusetts Chapter of the US Green Building Council. As the Co-Chair for USGBC's Greening Greenbuild Host Sub-Committee, Ms. McPike facilitated a group of volunteers who reduced the environmental impact of Greenbuild, the largest high performance buildings conference in the world, on the City of Boston in 2017. She is an active member of Northeast Sustainable Energy Association (NESEA), the United States Green Building Council of Massachusetts and the Women's Exchange for Leadership and Living Well (WELL).

Ms. McPike holds a Bachelor of Arts in Biology and Environmental Studies from Boston College and a Master of Science in Urban and Regional Policy from Northeastern University.

## Qualifications

### **WinnDevelopment**

WinnDevelopment has a national reputation for award-winning excellence in real estate development, acquiring and creating hundreds of housing properties in 10 states for 52 years. Winn is a long-term owner and committed to the communities we serve. The firm's portfolio includes housing for all income levels, asset classes and market types, office buildings, hotels, retail stores, medical offices, and structured parking. The recent and the majority of the firm's work has focused on large-scale mixed-use, mixed-income developments. Recent experience and pipeline opportunities include the acquisition, rehabilitation, and repositioning of undervalued multifamily housing in collaboration with private owners and/or public sector partners to strengthen communities and their quality of life.

The company is a leading advocate for middle-income housing, advocating for the creation of specific federal and state laws and funding programs to encourage the development of this much-needed funding set-aside. WinnDevelopment is also a pioneer in veterans-preference housing, successfully advocating for qualified allocations in state Low Income Housing Tax Credit (LIHTC) programs. This is evidenced by the firm's partnership with Soldier On, a private nonprofit organization committed to ending veteran homelessness that supports several of our communities in New Jersey, and developments like The Residences at Brighton Marine in Massachusetts, which offers affordable housing to hundreds of veterans and their families.

WinnDevelopment is also an award-winning national leader in the adaptive reuse of historic properties and iconic structures for residential uses. Over its history, the company has transformed 41 vacant historic properties in the Mid-Atlantic and Northeast into nearly 5,000 mixed-income homes. Since December 2012, WinnDevelopment has transformed 16 historic properties, in three states and the District of Columbia, into residential use, totaling more than 1,300 units, with total development costs exceeding \$519 million. We have an additional 300 adaptive-reuse units under construction, with 400 adaptive-reuse units set to begin construction through the end of the year.

The rehabilitation of existing housing is another significant component to WinnDevelopment's experience. Since July 2015, Winn has led more than 27 occupied rehabilitation projects -- exceeding 3,800 units -- across properties in six states and the District of Columbia, with total development costs exceeding \$640 million. In addition, the company currently has more than 300 units under in-place rehabilitation in two states, with an additional 1,300 occupied units set to begin construction over the next twelve months.

Lastly, new construction has quickly become one of WinnDevelopment's largest and fastest growing sectors. Since 2018, Winn has completed 602 new construction units at seven properties in three states, with total development costs exceeding \$205 million. In addition, the company currently has an additional 1,000 units set to begin construction over the next twelve months.

## WinnCompanies: Sustainable, “People First” Placemaking

*WinnCompanies is a private, family-owned company that is the largest manager of affordable housing, the second-largest manager of privatized military housing and the one of the largest managers of all rental housing in the United States.*

For nearly 50 years, WinnDevelopment and WinnResidential have worked in tandem with community stakeholders to deliver high-quality housing and create communities that residents are proud to call home. We develop, operate and own **every type of multi-family housing, including market rate, mixed-use, middle-income, affordable and senior housing.**

WinnCompanies operates **105,000 apartments across 23 states.** Included within this large geography, we own and manage **111 multifamily properties,** totaling nearly **13,715 units,** in 11 states and the District of Columbia. The development projects that started the company 1971 remain in its portfolio today – gaining tremendous value through long-term strategic refinancing and rehabilitation.

We believe creating and operating successful communities starts with safe, stable, quality housing. This commitment is reflected by our nationwide Housing Stability Program, which aims to **reduce eviction filings and formal eviction rates across our owned portfolio by 50% over the next five years.** The program uses education and outreach; early intervention, communication and coordinated financial assistance; integrated payment plans; and accountable legal support. This program has received **national recognition** from the White House, the National Apartment Association (NAA), and the Urban Land Institute (ULI).

WinnCompanies has played a major role in housing advocacy and policymaking at the federal, state and local level. We are the **leading national advocate for workforce housing,** partnering on legislation and financing programs to stimulate the development of middle-income housing. The company is also an industry leader in sustainability: environmentally, socially and economically and invests **more than \$30 million in energy efficiency and water conservation** projects across our portfolio.

Integrating diversity into the company’s management practices has been vital to our success and provides opportunities to facilitate organizational growth, harness employee potential, achieve performance goals, and enhance resident and employee satisfaction. We are proud that our commitment to diversity has resulted in **more than 60% of our workforce being comprised of minorities** and nearly half of our workforce comprised of women. It is important that our company’s leaders reflect the diverse employee population; **non-white team members hold 60% of all managerial and supervisory positions** at WinnCompanies.

## WinnDevelopment: A Trusted Partner

WinnDevelopment, based in Boston and with regional offices in New York and Washington DC, has 50 employees and is expert at site planning, securing entitlements, community outreach, and construction. Development partners trust the company with their projects because the company is highly selective and focused on quality. It only buys, develops, and manages **six to eight properties each year.**

WinnCompanies has **never defaulted on a loan or missed a mortgage or tax payment.** In the last 10 years alone, the company has completed **40 multifamily projects, approaching \$1.2 billion in total development costs.** Its integrated capabilities in property development and management, combined with its financial and regulatory expertise, make it a trusted partner in the industry.

Winn has acquired and developed real estate valued at **more than \$3 billion** over its five-decade history and has a long and successful track record of investing capital on the behalf of banks and institutions, a **\$50 million equity fund** on the behalf of Dupont’s pension fund.

## Award-Winning Excellence

We offer unmatched expertise at assembling innovative combinations of public and private financing. Some of the financing tools we have used include Federal and State Historic Tax Credits, 4% and 9% State and Federal Low Income Housing Tax Credits, New Market Tax Credits, Energy Grants, Federal Home Loan Bank of New York Affordable Housing Program, Federal Home Loan Bank of Boston Affordable Housing Program, Brownfield Tax Credits, City-based HOME Funds, MassHousing Workforce Opportunity Fund, U.S. Department of Housing and Urban Development (HUD) Project-Based Section 8 Subsidies, Housing Development Incentive Program (HDIP) and private debt and equity, to name a few.

Our work has earned accolades from city and state agencies, local and national industry associations and nonprofits for achieving historic preservation, positive community impact, and for our unique ability to combine historical elements with state-of-the-art sustainability and design

2021 Preserve Rhode Island Rhody Awards for Historic Preservation:

*Prospect Heights, Pawtucket, RI*

2021 Multifamily Executive Magazine MFE Award for Mixed-Income

Development: *The Residences at Brighton Marine, Brighton, MA*

2021 Novogradac Journal of Tax Credits Award for Historic Preservation:

*The Tyler, East Haven, CT*

2021 Preservation Massachusetts Thomas M. Menino Award:

*Cobbet Hill, Lynn, MA*

2020 Affordable Housing Finance Readers' Choice Awards - Overall Best

Development and Best Green Development: *The Tyler, East Haven, CT*

2020 National Apartment Association (NAA) Excel Awards - Large

Community of the Year: *Mystic Place, Medford, MA*

2020 Massachusetts Apartment Association (MAA) Excellence Award

for Large Community of the Year (Before 1999): *The Village at Brookline, Brookline, MA*

2019 ULI Jack Kemp Excellence in Affordable and Workforce Housing

Award: *The Watson, Quincy, MA*

2019 Multifamily Executive Magazine Excellence Award for Mixed-Use

Development: *Sibley Square, Rochester, NY*

2019 National Apartment Association (NAA) Excel Return on Energy

Award for Water Reduction: *Parkway Heights, Everett, MA*

2019 National Affordable Housing Management Association (NAHMA)

Communities of Quality Award for Exemplary Elderly Development: *Alice G. Winn Family Heritage House, Newburyport, MA*

2018 National Affordable Housing Management Association (NAHMA)

Communities of Quality Award for Exemplary Family Development:

*Castle Square, Boston, MA*

2018 National Affordable Housing Management Association (NAHMA)

Communities of Quality Award for Turnaround of a Troubled Property:

*Atlantic Apartment Homes, Washington, DC*



## Leaders in Preserving Historic Landmarks

*WinnCompanies is the nation's leading developer of historic and iconic buildings for use as residential housing and has transformed 26 historic properties into more than 2,400 units of mixed-income housing in mixed-use communities. Today, these properties are collectively valued at \$700 million and all but one or two, which have been sold, are managed expertly by WinnResidential.*

*Two dozen of our adaptive reuse properties are listed on the National Register of Historic Places and we currently manage dozens of apartment complexes born from the historic bones of textile mills, New Deal-era schools and other landmark structures in Massachusetts, Connecticut, Rhode Island, New York, Pennsylvania, Virginia and Washington, DC.*



### *The Tyler | East Haven, CT*

- \$32M transformation of former East Haven High School into 70 units of age-restricted, mixed-income housing
- Nation's first multifamily project to use historic rehabilitation tax credits and be built to the Passive House Institute's rigorous EnerPHit standard for energy efficiency
- 14 of the 70 units are reserved for previously homeless persons/households or persons/households at risk of homelessness
- Town of East Haven retained ownership of the wings of the building containing the school's swimming pool, auditorium, and gymnasium, totaling 62,651 SF



### *Samuel Kelsey | Washington, DC*

- Built circa 1920, the property is listed on the National Register of Historic Places and was previously known as the Tompkins Building.
- Project delivered 150 units of affordable housing for elderly or disabled tenants as well as eight retail tenants that are all locally-owned small businesses.
- Financed by D.C. Housing Finance Agency, with LIHTC, D.C. Department of Housing and Community Development (DHCD) Housing Production Trust Fund (HPTF), D.C. Department of Energy & Environment (DOEE) Funds and Private Debt and Equity



### *Livingston School Apartments | Albany, NY*

- \$26M transformation of 230,000-square-foot former school into a 103-unit, mixed-income community for seniors
- WinnDevelopment added the former Philip Livingston Magnet Academy to the National Register of Historic Places to qualify for historic tax credits
- As part of the purchase agreement with the City of Albany, WinnDevelopment subdivided the site, allowing the school district to maintain a viable three-acre tract for a potential future development.
- Fully occupied just two months after obtaining the certificate of occupancy.



## Fully-Integrated Mixed-Use, Mixed-Income Communities

*The recent work of WinnDevelopment has focused on large scale mixed-use and mixed-income developments; and, the acquisition, rehabilitation and repositioning of under-valued multifamily properties, working with private owners and/or public sector partners to strengthen communities and their quality of life. Our teams are well-equipped to handle the complex financing structures and variable timelines to deliver a successful synergy of “live-work-play.”*

*The company has developed and managed tens of thousands of market-rate, workforce and affordable housing units and more than 1 million square feet of mixed use developments that include retail and commercial uses up and down the East Coast of the United States.*



### *Sibley Square | Rochester, NY*

- The \$200 million revitalization of the 1.1 million square feet historic department store
- Sibley Square boasts 280 units of luxury market rate, middle income and affordable housing, expertly integrated with more than 400,000 sq. ft. of office and co-working space, 75,000 sq. ft. of retail space, including

The Mercantile on Main, Rochester’s largest food hall, and 68,000 sq. ft. of high-tech business incubator space

- Financed by local, state and federal loans, private capital, tax abatements, and historic, new market and low income tax credits



### *Mary Ellen McCormack | Boston, MA*

- Joint development partnership between the AFL-CIO Housing Investment Trust, the Boston Housing Authority (BHA), and WinnCompanies
- Four-phase, \$1.6 billion redevelopment will transform existing 27-acre, 1,016 -unit public housing complex into a mixed-use community with 3,000 mixed income apartment

homes, retail, and community uses.

- 200 units of new workforce/ middle income housing will be created in the first two phases
- Project also envisions a multi-purpose community center, indoor and outdoor event space, walking and bike paths and a community grocery store



### *201 Canal | Lowell, MA*

- \$38M new construction development on two vacant parcels in the Hamilton Canal Innovation District
- 125 units and 5,000 square feet of commercial space
- Meets all housing needs: low income (30%, 50% and 60% AMI), “forgotten middle” (80-120% AMI), and market rate

- Enterprise Green Communities certified
- Public realm improvements include a courtyard, approved by the City of Lowell and the Lowell Historical Board, and an enclosed skybridge, to complement the City’s new landmark bridge over the Pawtucket Canal.

# Investing in The “Missing” Middle with Workforce Housing

*WinnCompanies is committed to sustainable development that meets the economic, environmental, and social needs of communities. Over the course of our 48-year history, we’ve partnered with numerous public and quasi-public agencies, leveraging private market and programmatic funding, to coordinate, plan and finance smart growth, transit-oriented projects that address all income levels.*

*Having worked hand-in-hand with our own management company for decades, WinnDevelopment brings an experienced owner’s perspective to its work as a developer. Our shared operational services structure, including accounting, marketing, technology and compliance, can help produce savings from planning through stabilization.*



## *The Watson | Quincy, MA*

- Joint venture between WinnCompanies and NeighborWorks Housing Solutions
- 140-unit community is the largest, middle income project financed with MassHousing’s innovative Workforce Housing Initiative
- First project in state to combine Workforce and Housing Development Incentive Program (HDIP) funds
- Wide range of incomes; 50%AMI, 120% of AMI, and market rate/unrestricted units



## *The Residences at Brighton Marine | Boston, MA*

- Joint venture of Brighton Marine, a nonprofit offering veterans services and WinnCompanies
- Largest 100% veteran’s preference community in the United States
- Wide range of incomes served, from <30% AMI to 135% AMI
- Five years and more than six different housing and government funding programs were required to make this single project possible
- LEED Gold-certified building houses 102 apartments and amenity space



## *Residences at Harborwalk and Harbor125 | East Boston, MA*

- 22 affordable rental units and 30 market-rate and workforce housing condominiums
- Of the 30 condominium units, 16 are market rate; 14 restricted to households earning between 80% and 120% AMI
- Both of the new buildings achieved LEED Gold certification
- More than 850 homebuyers applied and qualified for the 14 workforce condominiums
- Adjacent to 12-acre mixed use development, overlooking Boston Harbor in East Boston

## Occupied Rehabilitation Track Record

WinnDevelopment has overseen the completion of 29 occupied rehabilitation projects, totaling more than 4,400<sup>1</sup> units, at its owned properties in six states and the District of Columbia since July 2015. The total development costs for those projects were more than \$747<sup>2</sup> million. The company currently has more than 370<sup>3</sup> occupied units under rehabilitation in two states, with an additional 1,550<sup>4</sup> units in pre-development in four states.

These occupied rehabilitations take place without displacing our residents. In addition, we work with city, county and state leaders across the country to assemble public and private capital to help communities provide badly needed quality housing in every category.



### *Atlantic Apartment Homes | Washington, DC*

- \$69 million occupied rehabilitation of two neighboring Section 8 communities completely modernized 303 units, preserving the affordability for 30 more years.
- Redevelopment introduced new and enhanced services to residents, including job placement programs, expanded early childhood learning opportunities and new computer learning options
- WinnDevelopment partnered with DC DOEE to install a 651 KW solar renewable energy facility on the roofs of Atlantic Terrace to create the largest community solar project in the District.



### *City Crossing | Jersey City, NJ*

- Preserved and drastically improved 131 units of physically and financially at risk affordable family housing
- Partnership with Greater Bergen Community Action (GBCA) introduced new resident services, including financial literacy training, job training, and good housekeeping skills training
- Of the 146 construction workers who participated on the rehab, 108 were minorities and 38 were low-income residents from the immediate area
- Green retrofit will allow residents to save 20% on their monthly gas and electricity bills compared to before the rehabilitation



### *Trails at Malone | Malone, NY*

- Occupied rehabilitation of 128-unit low income housing community completed in 2017
- Financed with 9% LIHTC credits
- 80 jobs created during the redevelopment of The Trails at Malone. Hiring preferences were given to local contractors and vendors, including residents.
- WinnDevelopment secured an exemption on material sales tax due to the Article XI HDFC financing structure of the property

**Exhibit 10.**

**Letters of Interest & Financial Statement**



Mary A. Thompson  
Senior Vice President

Community Development Banking  
100 Federal St  
Boston, MA 02110  
T 774-454-9609  
Mary.a.thompson@BofA.com

Jillian Douglass  
Administrator  
Affordable Housing Growth and  
Development Trust Fund Board  
367 Main Street  
Hyannis, MA 02601

Re: Bank of America – Letter of Support

Dear Administrator Douglass,

I am writing on behalf of Bank of America to support WinnDevelopment's application to the Affordable Housing Growth and Development Trust Fund Board (the "Trust") for funding for their new development, the Harbor Vue Hyannis in Barnstable, MA.

Bank of America and Winn have a longstanding history of working together and have successfully partnered on the transformation of many redevelopment projects, similar in scope and complexity. Bank of America is confident that their proposal will create much-needed, high quality and well-managed mixed-income housing in the village of Hyannis and that Winn will bring the much-needed resources to fruition.

As the Trust prepares to review funding applications, I want to express the Bank's support of Winn and their capabilities and hope that you will look favorably upon their request.

Please contact me should you have any questions.

A handwritten signature in black ink that reads "Mary A. Thompson". The signature is written in a cursive style with a long horizontal line extending to the right.

Mary A. Thompson  
Senior Vice President  
Bank of America

Jillian Douglass  
Administrator  
Affordable Housing Growth and  
Development Trust Fund Board  
367 Main Street  
Hyannis, MA 02601

Re: Boston Financial – WinnDevelopment – Harbor Vue Hyannis

Dear Administrator Douglass,

Boston Financial is providing this letter in support of WinnDevelopment’s application to the Barnstable Affordable Housing Growth and Development Trust Fund Board (the “Trust”) for the Harbor Vue Hyannis in Barnstable, MA.

Boston Financial and Winn have worked together on many projects in the past, and our firm is wholly confident in their ability to construct a new mixed-income community that will be a benefit to Hyannis and its people for years to come.

As the Barnstable Affordable Housing Growth and Development Trust Fund Board reviews applications for funds, I wish to express our support for this project and our faith in WinnDeveopment to deliver an excellently built and managed community.

Please do not hesitate to reach out with any questions.

Sincerely,



Robert Charest  
Managing Director  
Boston Financial Investment Management

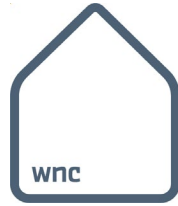

August 18, 2023

Jillian Douglass  
Administrator  
Affordable Housing Growth and  
Development Trust Fund Board  
367 Main Street  
Hyannis, MA 02601

Re: WNC – Letter of Support for WinnDevelopment

Dear Administrator Douglass,

WNC & Associates is providing this letter in support of WinnDevelopment’s application to the Barnstable Affordable Housing Growth and Development Trust Fund Board (the “Trust”) for the Harbor Vue Hyannis in Barnstable, MA.

WNC and Winn have worked together on many projects in the past, and our firm is wholly confident in their ability to construct a new mixed-income community that will be a benefit to Hyannis and its people for years to come.

As the Barnstable Affordable Housing Growth and Development Trust Fund Board reviews applications for funds, I wish to express our support for this project and our faith in WinnDevelopment.

Please do not hesitate to reach out with any questions. I can be reached at 972-965-4620.

Sincerely,

A handwritten signature in blue ink, appearing to read 'David Ciminelli', is written over a light blue rectangular background.

David Ciminelli  
Vice President – Originations

Audited Financial Statements:

<https://www.dropbox.com/sh/eaue6x94qntd3ty/AABQoTWKeP6bGXECQbxghEUva?dl=0>



## **Exhibit 11.**

### **Project Narrative**

## **Harbor Vue Project**

307 Main Street, Hyannis, MA



### ***Project Summary***

Harbor Vue is a new, ground up construction of 120 units at the currently obsolete vacant, former TD Bank Branch located in the heart of downtown Hyannis. The 1.9 acre site serves as the entrance into Downtown Hyannis and is positioned at the crux of multi-modal transportation hubs – bikes, rail, ferry and car. The site is located adjacent to Cape’s main rail transit hub and hospital and is less than a ten minute walk to the Ferry’s that connect to the surrounding islands. The project is supported by the Town of Barnstable Planning Staff and is viewed as a critical next step in solving the Cape’s housing crisis for year round residents. In addition to being a high priority for the state, and town, the project has attracted strong interest from Bank of America as the debt and equity provider. These new units will be concentrated within the workforce housing and middle-income demographic so sorely lacking in the Cape. Currently, Barnstable’s subsidized housing inventory is at 6.78%, this project would allow all 120 units to count towards increasing the Town’s SHI and address the need for long-lasting, mixed income housing. The Project will include indoor and outdoor amenity spaces for residential use featuring a communal lounge, fitness room, rooftop deck, bicycle storage and on-site parking (including EV spaces). The units will include modern, high quality finishes, in unit laundry and sustainable designed heating/cooling systems.

### ***Site Location***

This location is second to none on Cape Cod. The site sits diagonally across the street from the Hyannis Transportation Center, which consists of both the regional bus terminal and Hyannis train station. Directly south of the site is Hyannis Harbor, which is home to the Steamship Authority that offers ferry services to and from the island (Nantucket and Martha’s Vineyard). The site is walkable to the Cape Cod Hospital (0.5 miles to the east) and even 1 mile from the Cape Cod Gateway Airport. Not only is the site TOD, but it would also serve as a centerpiece of the transportation hub of the Cape.

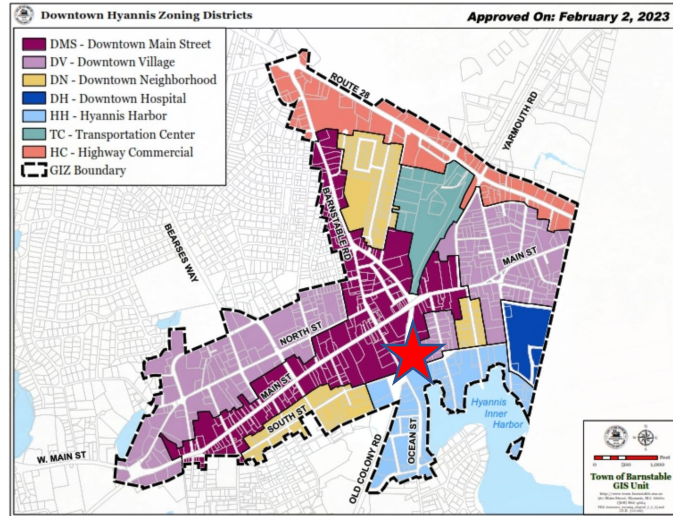

In addition to the tremendous TOD accessibility, the site is centrally located on Main Street in Hyannis – a wonderful place to visit to shop, dine and be entertained. Shops, restaurants, and other fun attractions, all walkable from the proposed project – making this an extremely desirable place for people to work, play and call home. Lastly, the proximity to the Hospital will foster further workforce potential for this medical facility currently suffering from staff shortages and the resulting public health risks.

***Development Program and Timing***

The development program includes approximately 120 units (twinned 4% and 9% deal) of mixed-income housing for the workforce and families, earning a range of incomes, from affordable units (30-60% AMI; 77 total), middle income (100-120% AMI; 32 total), and market rate (11 total). Winn is proposing that approximately 90% of the units of the entire project would be income restricted. This diverse unit mix will offer a wide variety of unit types and income ranges to the Cape’s and, specifically, Barnstable’s housing inventory. This coincides with the State’s and Town’s vision for providing high quality, accessible housing throughout the Commonwealth and in otherwise unattainable locations. EOHLIC prefers to invest their resources into projects that show strong local support and are encouraged by the municipality they are in. This is a critical component to a competitive EOHLIC application. Therefore, Harbor Vue is seeking 2 million in BAHGDT funding.

With the acute need for housing on the Cape being so great, Winn recognized the need to quickly pursue this unique opportunity. After securing site control in June of 2023, Winn is endeavoring to design, entitle, and permit the project as quickly as possible (this Summer) and is prepared to close on the land once such permits are in place and subsequently make a financing application for Low Income Housing Tax Credits in the Summer of 2024. Indeed, **sites like this for substantial multi-family development in the Cape do “not wait around for long”** – and Winn is willing to go ‘at-risk’ to control this unique site for a public-private funding plan.

***Green Initiatives & Sustainable Design***

WinnDevelopment will improve the underutilized parcel to create new, sustainably designed, modern housing. WinnDevelopment is an industry leader and trusted partner in integrating energy efficiency and high-performance design in its development projects. With an internal team of Energy &

Sustainability professionals, Winn has built a unique capacity and expertise in building science and best practices, working closely with its design teams on every project. In addition, ICON, the project architect, has several Certified Passive House Consultants on staff, and the project team will engage a sustainability consultant for energy modeling and sustainability consulting. The team is committed to pursuing a high level of energy performance at 307 Main Street, going above and beyond DHCD's new QAP Emphasis on Green, Sustainable, and Climate Resilient Design standards. The Project will incorporate Enterprise Green Communities mandatory criteria per the 2023-2024 QAP, Energy Star, and strive towards a Passive House certifiable design level.

We believe that this project truly embodies the perfect example for the State and Federal resources devoted to creating accessible housing. Furthermore, this project can **utilize the State's Coastal Cities monies** that were specifically allocated for exciting project such as this. As such, we are expeditiously moving forward to be in a position to close on this exciting, transformative piece of land by year end. We know that this transit oriented location is a key step towards solving the Cape's housing crisis.

#### ***Project Costs and Extraordinary Costs***

WinnDevelopment has been working with ICON to advance drawings. Throughout the drawing process, Winn will work with a reputable General Contractor to obtain competitively bid construction pricing. Currently, budgetary numbers are based off Winn's in house construction team based on projects of similar size and scale while taking into account the current economic climate and construction environment. In addition, the direct cost budget was provided by Kieth Construction Inc. The 120 unit development will cost approximately \$79.8MM or \$665k/unit. In order to maximize State resources, the project will be structured as a twinned deal with a 4% and 9% project.

While this projected budget includes some unique extraordinary site related costs, the project is likely **less costly per unit than any new construction project EOHLIC will be presented with on the Cape** given its wood-frame design, above ground parking, reasonable land costs (\$42K per unit), and economies of scale due to the substantial unit count of 120 (compared to most Cape opportunities that are well under 100 units).

Indeed, most of the extraordinary costs associated with this project and listed below are costs associated with doing work anywhere on the Cape and are not isolated to this site. Such costs include:

1. Hauling materials to this location – premium associated getting materials to the Cape;
2. Design – the project will go through extensive design review from Hyannis Historical Commission that will require pitched roofs and enhanced design features;
3. Demolition of the existing building – there are few undeveloped parcels of land available for development;
4. Construction Loan Interest Rate Premium – rates based on current economic conditions; and
5. Passive House – the project will be passive house certified.

We believe that this project truly embodies the perfect example for the State and Federal resources devoted to creating accessible housing. Furthermore, this project can utilize the State's Coastal Cities monies to reduce the burden on HLC housing-only resources. As such, we are expeditiously moving forward to be in a position to close on this exciting, trans-formative piece of land by end of April, 2024. We know that this transit-oriented location is a key step towards mitigating the Cape's housing crisis which results in workforce shortages and public safety and health concerns (i.e. lack of Firefighters, hospital workers and service workers).

Boston • Baltimore • El Paso • Fresno • Honolulu • Nashville • Los Angeles  
New York • Philadelphia • Rochester • Washington, DC



[winncompanies.com](http://winncompanies.com)

